

AGGREGATE DITCH (SPECIAL) DETAIL  
 LT. STA. 1+80 TO 3+75  
 RT. STA. 2+00 TO 3+25  
 LT. STA. 4+25 TO 5+90  
 RT. STA. 4+20 TO 5+55  
 RT. STA. 5+95 TO 8+50

**GENERAL NOTES**

THE CONTRACTOR SHALL CONTACT JULIE (1-800-892-0123) BEFORE COMMENCING WORK. UNDERGROUND UTILITIES SHOWN ON THE PLAN SHEETS WERE OBTAINED FROM LOCAL UTILITY COMPANIES AND OTHER AVAILABLE SOURCES. LOCATIONS, SIZE, MATERIAL, DESCRIPTION, OR TYPE OF EXISTING UTILITIES INDICATED ON THE PLANS ARE NOT REPRESENTED AS BEING ACCURATE, SUFFICIENT, OR COMPLETE AND SHALL BE CONSIDERED APPROXIMATE. ABOVE GROUND UTILITY LOCATIONS ARE SHOWN AS FOUND DURING THE INITIAL SURVEY FIELD WORK AND MAY NOT REFLECT CURRENT CONDITIONS. THE CONTRACTOR IS RESPONSIBLE FOR MAKING HIS OWN DETERMINATION AS TO THE TYPE AND LOCATION OF UNDERGROUND AND OTHER UTILITIES AS MAY BE NECESSARY TO AVOID DAMAGE THERETO. THE CONTRACTOR SHALL BE RESPONSIBLE FOR LOCATING ALL UNDERGROUND UTILITIES AND COORDINATION WITH UTILITY COMPANIES.

THE FOLLOWING RATES HAVE BEEN USED TO CALCULATE PLAN QUANTITIES:  
 AGGREGATE DITCH (SPECIAL) 1.75 TONS/CU YD  
 AGGREGATE SURFACE COURSE, TY-B 2.0 TONS/CU YD

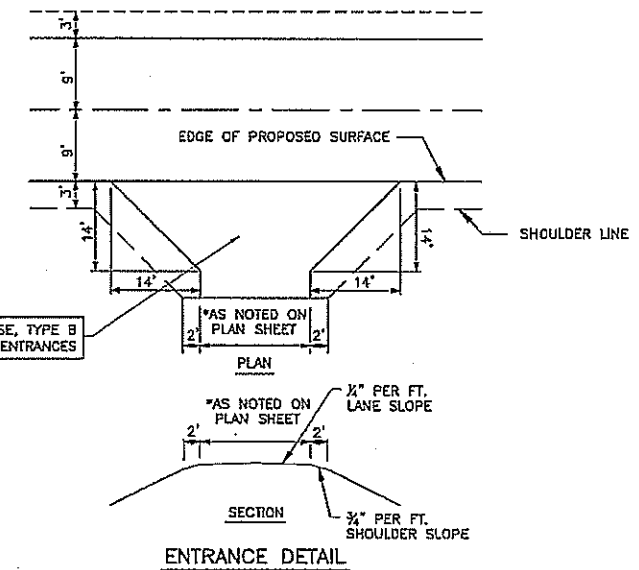

**COMMITMENTS**

- U.S. ARMY CORPS OF ENGINEERS SECTION 404 NATIONWIDE PERMIT.
- TREES THREE (3) INCHES OR GREATER IN DIAMETER AT BREAST HEIGHT SHALL NOT BE CLEARED BETWEEN APRIL 1 AND SEPTEMBER 30 OF ANY GIVEN YEAR.

**SCHEDULE OF KNOWN UTILITIES**

DESIGN STAGE JULIE NO. A221923537

UTILITY COMPANY	TYPE	CONTACT NAME	PHONE NUMBER	E-MAIL ADDRESS	MAILING ADDRESS
NORRIS ELECTRIC CO-OP	ELECTRIC	DOUG KUIER	618-873-8765	dklier@norriselectric.com	8543 N. STATE HIGHWAY 130, NEWTON, IL 62448
FRONTIER COMMUNICATIONS	COMMUNICATIONS	BRIAN VANGUNDY	618-395-6189	brian.vangundy@ftr.com	225 E. CHESTNUT ST. OLNEY, IL 62450
EJ WATER COOPERATIVE	WATER LINE	DEAN SWINGLER	217-925-5566	dswingler@ejwatercoop.com	108 S. MAIN STREET, DIETERICH, IL 62424
CITATION OIL & GAS CO.	PIPELINE	RODNEY TUCKER	618-676-1044	rtucker@cogc.com	3943 BIG FOUR ROAD, CLAY CITY, IL 62824

SUMMARY OF QUANTITIES			
CODE NO.	ITEM	UNIT	QUANTITY
X0322916	PROPOSED STORM SEWER CONNECTION TO EXISTING STORM SEWER	EACH	1
X0327301	RELOCATE EXISTING MAILBOX	EACH	1
X2300007	TRAFFIC BARRIER TERMINAL, TYPE 1	EACH	1
X2501000	SEEDING, CLASS 2 (SPECIAL)	ACRE	0.65
X2830495	AGGREGATE DITCH (SPECIAL)	TON	315
Z0013798	CONSTRUCTION LAYOUT	L SUM	1
20100500	TREE REMOVAL, ACRES	ACRE	0.20
20200100	EARTH EXCAVATION	CU YD	930
20300100	CHANNEL EXCAVATION	CU YD	505
20700110	POROUS GRANULAR EMBANKMENT	TON	100
20800150	TRENCH BACKFILL	CU YD	50
28100807	STONE DUMPED RIPRAP, CLASS A4	TON	528
40200800	AGGREGATE SURFACE COURSE, TYPE B	TON	715
50100100	REMOVAL OF EXISTING STRUCTURES	EACH	1
50105220	PIPE CULVERT REMOVAL	FOOT	94
50300225	CONCRETE STRUCTURES	CU YD	31.2
50300280	CONCRETE ENCASMENT	CU YD	2.8
50400405	PRECAST PRESTRESSED CONCRETE DECK BEAMS (21" DEPTH)	SQ FT	1344
50800105	REINFORCEMENT BARS	POUND	4080
50900205	STEEL RAILING, TYPE S1	FOOT	117
51201600	FURNISHING STEEL PILES HP12X53	FOOT	161
51202305	DRIVING PILES	FOOT	161
51203600	TEST PILE STEEL HP12X53	EACH	1
51500100	NAME PLATES	EACH	1
54213450	END SECTIONS 15"	EACH	1
54200217	PIPE CULVERTS, CLASS D, TYPE 1 12"	FOOT	40
54200220	PIPE CULVERTS, CLASS D, TYPE 1 15"	FOOT	40
55080360	STORM SEWERS, CLASS B, TYPE 2 15"	FOOT	60
55080410	STORM SEWERS, CLASS B, TYPE 2 24"	FOOT	60
60100915	PIPE DRAINS 6"	FOOT	20
60219000	MANHOLES, TYPE A, 4'-DIAMETER, TYPE B GRATE	EACH	2
63100075	TRAFFIC BARRIER TERMINAL, TYPE 5A	EACH	2
63100167	TRAFFIC BARRIER TERMINAL, TYPE 1 (SPECIAL) TANGENT	EACH	1
67100100	MOBILIZATION	L SUM	1
72501000	TERMINAL MARKER - DIRECT APPLIED	EACH	4

\*SPECIALLY ITMES

<b>CHARLESTON ENGINEERING, INC.</b> CONSULTING ENGINEERS - LAND SURVEYORS 105 NORTH MITCHELL AVENUE OLNEY, ILLINOIS 62450 P.O. BOX 327 OLNEY, ILLINOIS 62450 ILLINOIS DEPARTMENT OF PROFESSIONAL REGULATION REGISTRATION #184.003513	DESIGNED - BMB	REVISED -  1/2/2024	STATE OF ILLINOIS DEPARTMENT OF TRANSPORTATION	SUMMARY OF QUANTITIES, TYPICAL SECTIONS, AND GENERAL NOTES	ROUTE	SECTION	COUNTY	TOTAL SHEETS	SHEET NO.
	DRAWN - BMB	REVISED -			T.R. 35A	08-09133-00-BR	RICHLAND	18	2
	CHECKED - BMB	REVISED -			CONTRACT 95936		ILLINOIS	PROJECT 3BML(437)	