



# Illinois Department of Transportation

Office of Intermodal Project Implementation / Division of Aeronautics  
1 Langhorne Bond Drive / Springfield, Illinois 62707-8415

January 16, 2024

SUBJECT: Decatur Airport  
Decatur, Illinois  
Macon County  
Illinois Project Number: DEC-4822  
SBG Project Number: N/A  
Contract No. DE084  
Item No. 09A, January 19, 2024 Letting  
Addendum A

## NOTICE TO PROSPECTIVE BIDDERS

Attached is an addendum to the plans or proposal. This addendum involves revised and/or added material.

Reason for Addendum:

This addendum includes a modification to the jointing notes on sheet 6 of the plan set.

To All Plan Holders:

See Revised Sheet 6.

Plan Changes:

Replace Sheet 6 in the plans with the attached revised Sheet 6.

Special Provisions Changes:

N/A

Schedule of Prices Changes:

N/A

Prime contractors must utilize the enclosed material when preparing their bid and must include any changes to the Schedule of Prices in their bid.

Questions on this addendum may be directed to Lindsay Hausman of Hanson Professional Services Inc. at 217.747.9314.



Decatur Park District  
Decatur Airport  
910 South Airport Road  
Decatur, IL 62521

**RECONSTRUCT SELECT PORTIONS OF THE AIRPORT TERMINAL ENTRANCE ROAD**

Illinois Proj. No.: DEC-4822

NO.	DATE	DESCRIPTION		
		DES	DWN	REV
1	1/16/24	Addendum A	LDH	LDH

ISSUE: NOVEMBER 17, 2023

PROJECT NO: 22A0100D

CAD FILE: C-501-DET.DWG

DESIGN BY: HLE 04/11/2023

DRAWN BY: HLE 04/11/2023

REVIEWED BY: LDH 11/2/23

SHEET TITLE

**PATCHING DETAILS**

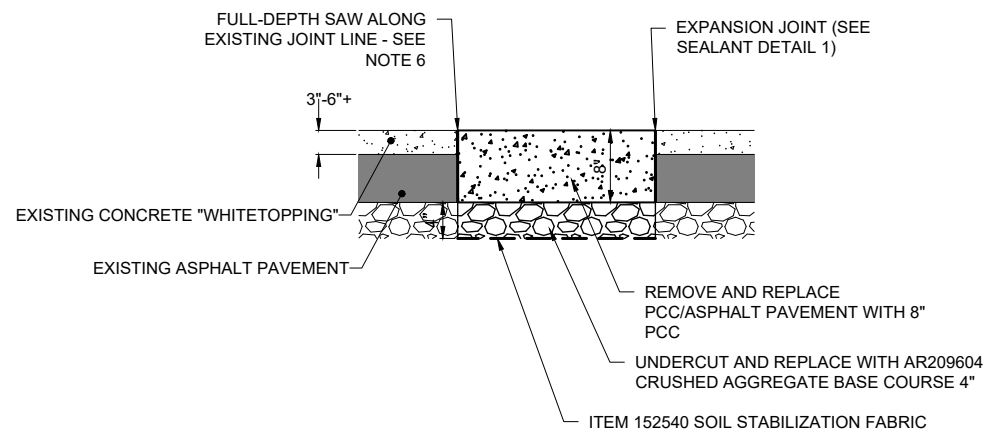

**PAVEMENT PATCHING DETAIL**  
NOT TO SCALE

**NOTES:**

1. RESIDENT ENGINEER/TECHNICIAN WILL CONFIRM AND LAYOUT PATCHING LIMITS.
2. PCC MIX SHALL BE IDOT CLASS PP-2.
3. CRUSHED AGGREGATE BASE SHALL BE PAID FOR FOR UNDER PAY ITEM AR209604 "CRUSHED AGGREGATE BASE COURSE- 4" - PER SQUARE YARD.
4. SOIL STABILIZATION FABRIC SHALL BE PAID FOR UNDER PAY ITEM AR152540
5. ALL OTHER WORK AND MATERIALS SHOWN, INCLUDING JOINTING AND SEALING, SHALL BE INCLUDED IN AND PAID FOR UNDER PAY ITEM AR501508 "8" PCC PAVEMENT" - PER SQUARE YARD.
6. CARE SHALL BE TAKEN NOT TO DAMAGE EXISTING CONCRETE PANELS WHILE SAW-CUTTING AND REMOVING EXISTING PAVEMENT. CRACKED OR DAMAGED PANELS SHALL BE REMOVED AND REPLACED AT THE CONTRACTOR'S EXPENSE.

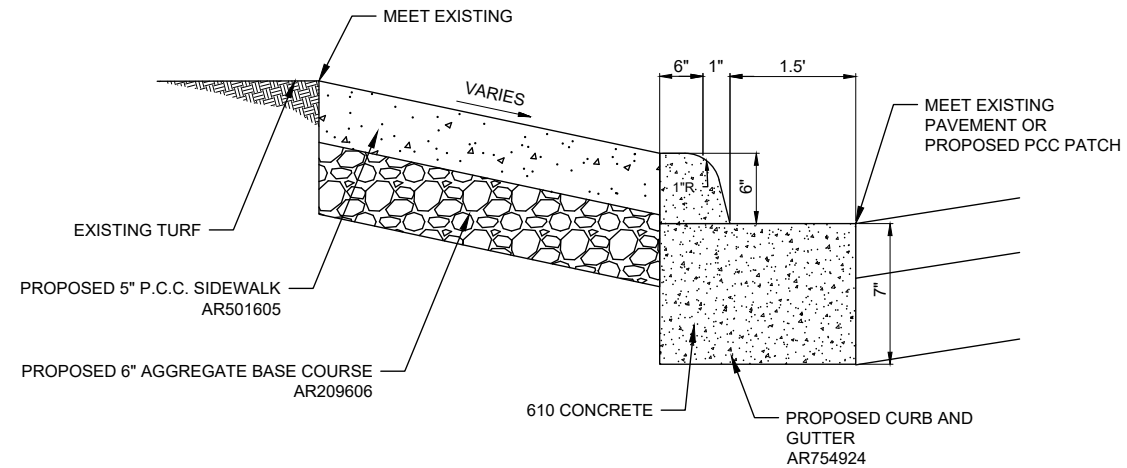

**PCC SIDEWALK (AR501605) AND COMBINATION CURB AND GUTTER REMOVAL AND REPLACEMENT (AR754924) DETAIL**  
NOT TO SCALE

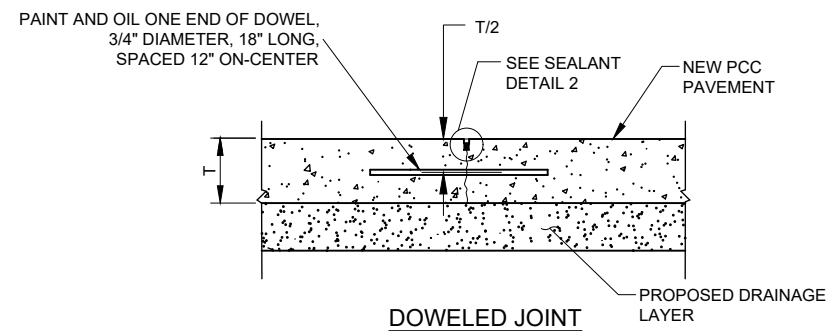

**DOWELED JOINT**

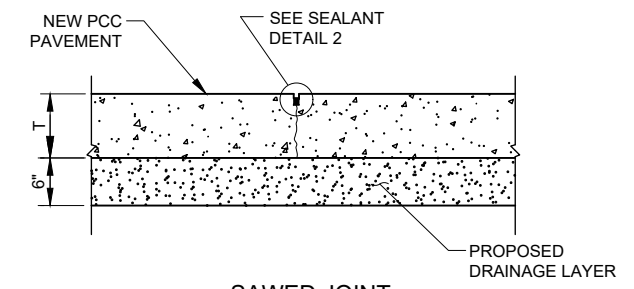

**SAWED JOINT**

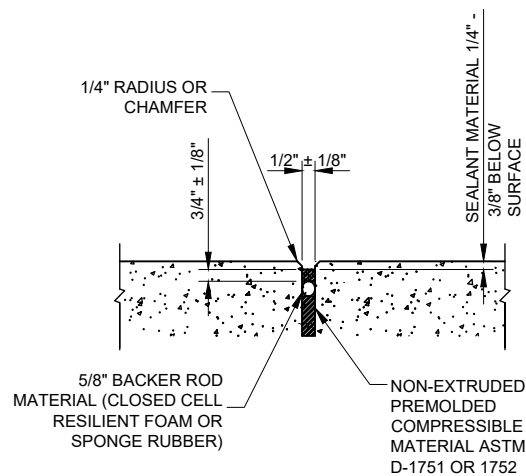

**DETAIL 1 - SEALANT**

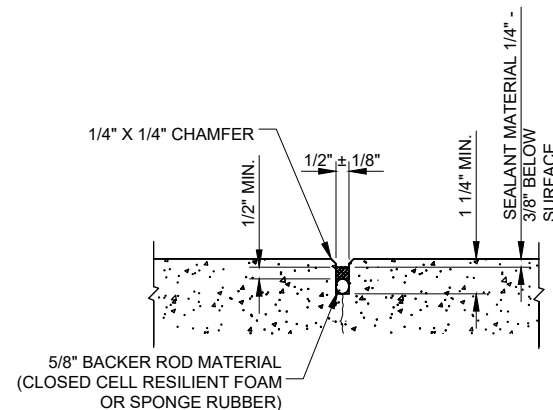

**DETAIL 2 - SEALANT**

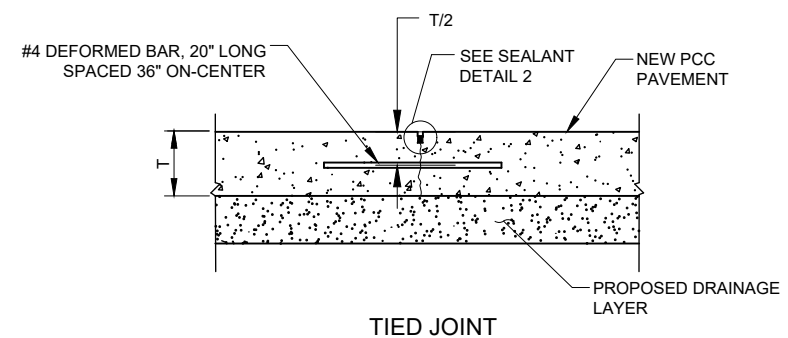

**TIED JOINT**

**JOINTING NOTES:**

1. JOINT SPACING SHALL MATCH EXISTING.
2. TRANSVERSE JOINTS SHALL BE SAWED JOINTS.
3. LONGITUDINAL JOINTS SHALL BE ALTERNATING SAWED AND TIED JOINTS.