

F.A.I. RTE. 80/94	SECTION 2626.2-R-2	COUNTY COOK/LAKE	TOTAL SHEETS 1207	SHEET NO. 124A
STA.		TO STA.		
FED. ROAD DIST. NO.		ILLINOIS FED. AID PROJECT		
CONTRACT NO. 62114		INDOT DES. NO. 0100987		

**GENERAL NOTES**

① See Standard Drawings 720-ICCA-01 through -03 for casting type 5 details.

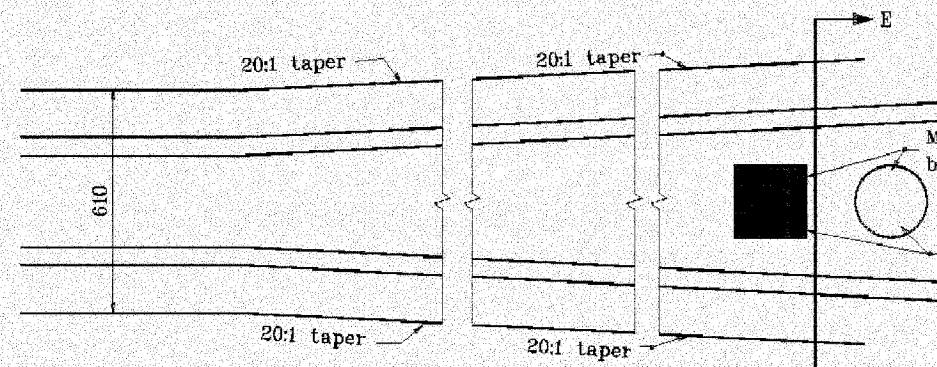

**PLAN VIEW AT  
MEDIAN OBSTRUCTION**

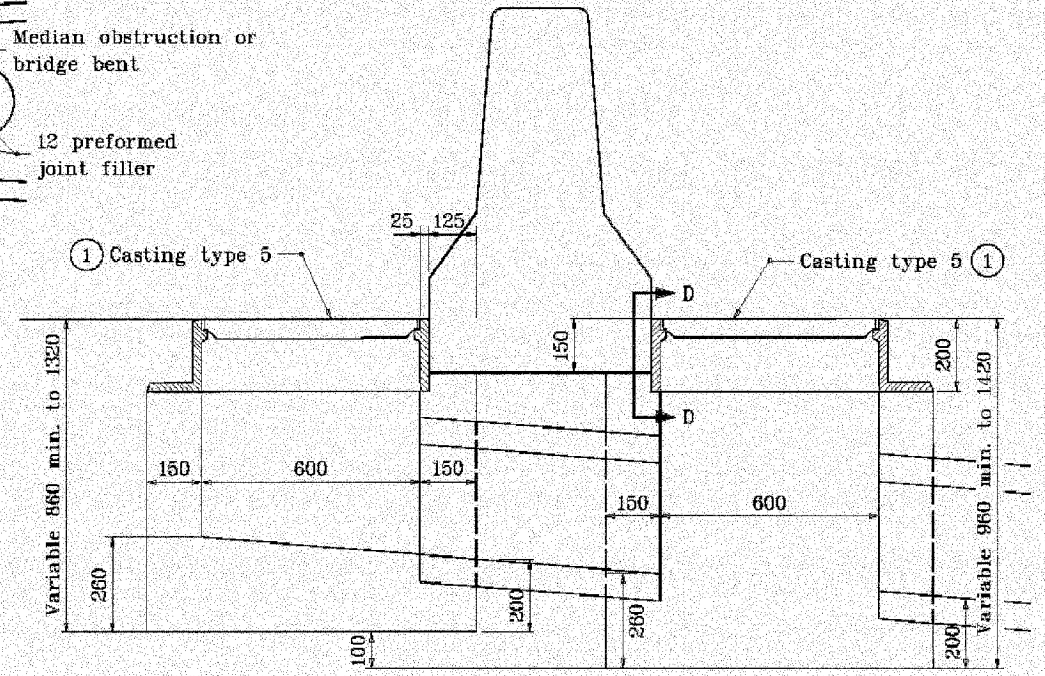

**SECTION C-C**

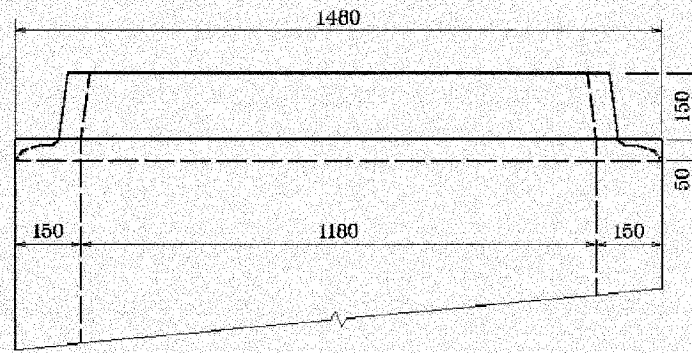

**SECTION D-D**

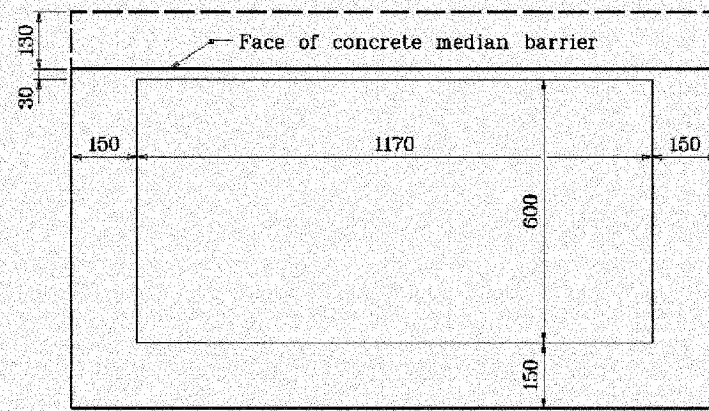

**TOP VIEW**

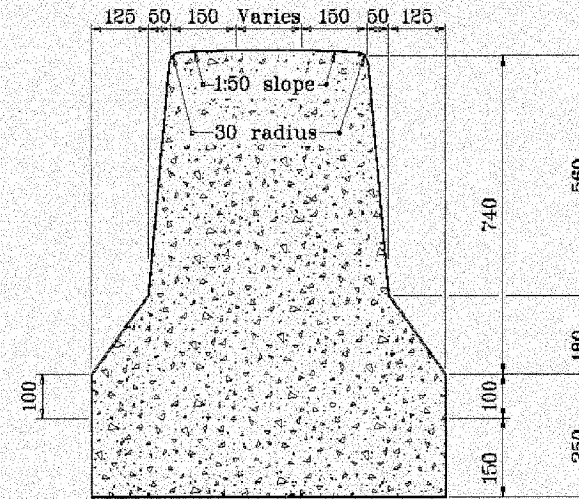

**SECTION E-E**

All dimensions are in mm unless otherwise specified.  
INDIANA DEPARTMENT OF TRANSPORTATION

**CONCRETE MEDIAN BARRIER**

11/16/00

602-R-388d  
3 of 5