

**ELEVATION
TYPICAL INTERIOR UNIT**
Even number of panels/interior unit required.

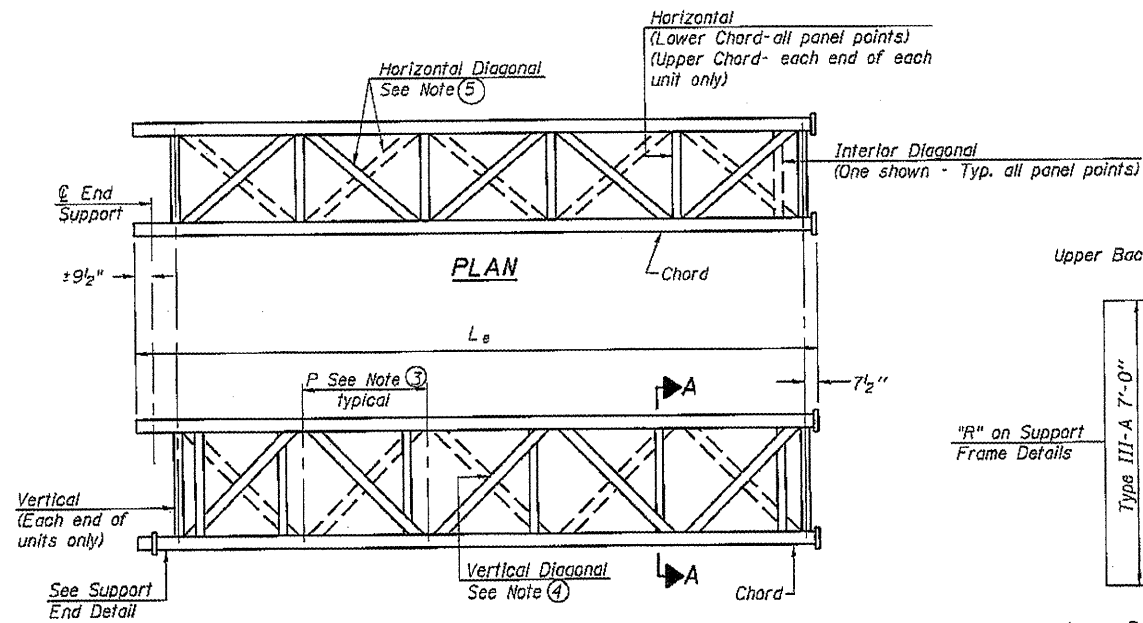

**ELEVATION
TYPICAL EXTERIOR UNIT**
Even or odd number of panels/exterior units allowed.

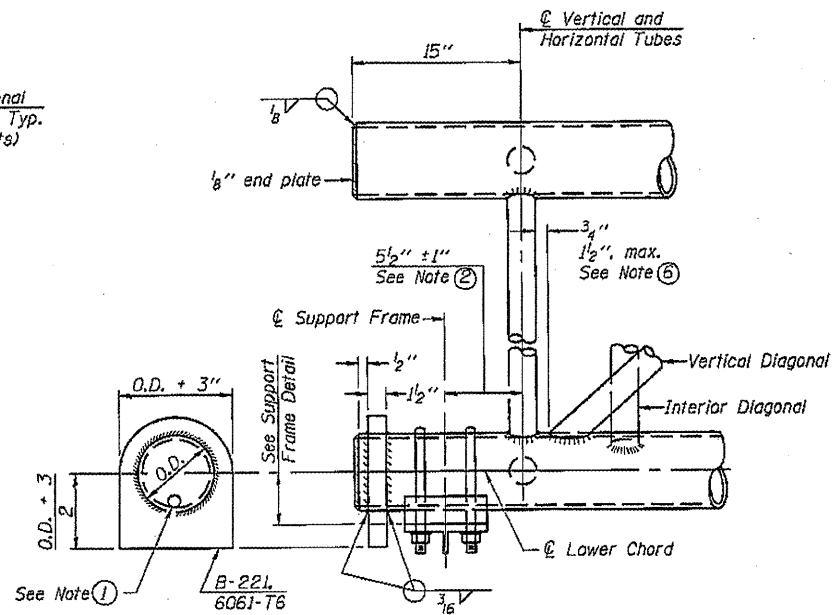

SUPPORT END DETAIL FOR EXTERIOR UNIT

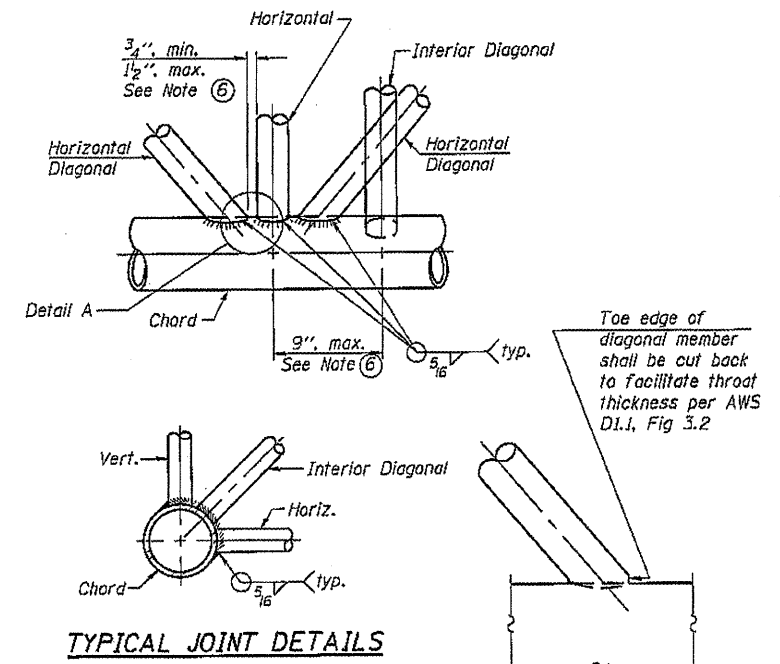

TYPICAL JOINT DETAILS

DETAIL A

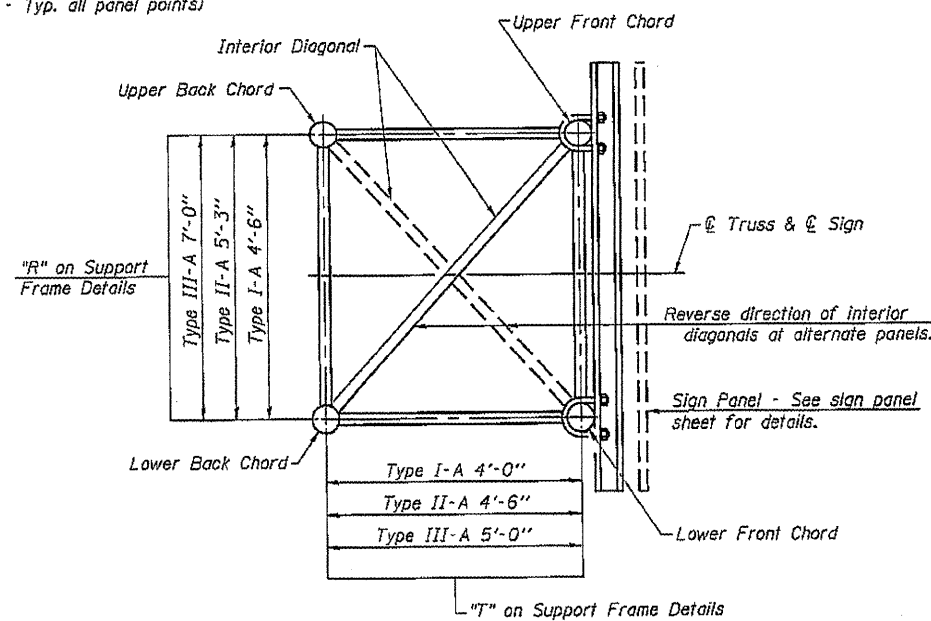

SECTION A-A

- ① Contractor may alternatively use standard aluminum drive-fit cap to close end. 1/2" ϕ drain hole in end plate/drive-fit cap. (Typ. at ends of all chords)
- ② 5 1/2" end dimension may vary by $\pm 1"$ to provide uniform panel spacing (P).
- ③ Panel spacing (P) shall be uniform for entire truss and between 4'-0" and 5'-0" for Type I-A or 4'-0" and 5'-6" for Types II-A and III-A.
- ④ Vertical Diagonals in front and back face shall alternate.
- ⑤ Hidden lines show wind bracing alternates direction between planes of top and bottom chords.
- ⑥ All diagonals shall be detailed for minimum offset from the panel point based on the following: Offset shall be such as to provide a 3/4" minimum to 1/2" maximum clearance between any diagonal and any horizontal or vertical member, and to provide clearance for U-bolt connections of signs or walkway brackets.

OS-A-2

1-20-11

FILE NAME =	USER NAME = kelley.jb	DESIGNED -	REVISED -
Sign Truss Plan Details\46196\4619651	Repl.dgn	DRAWN -	REVISED -
PLOT SCALE = 0.1802 ft / in.	CHECKED -	REVISED -	REVISED -
PLOT DATE = Sep-30-2011 10:29:05AM	DATE -	REVISED -	REVISED -

STATE OF ILLINOIS
DEPARTMENT OF TRANSPORTATION

OVERHEAD SIGN STRUCTURES - ALUMINUM TRUSS
DETAILS FOR TRUSS TYPES I-A, II-A AND III-A

SCALE: _____ SHEET NO. _____ OF _____ SHEETS STA. _____ TO STA. _____

F.A. RTE.	SECTION	COUNTY	TOTAL SHEETS	SHEET NO.
VAR	0-6_OVD51NSIBREEL12-23	SANGAMON	33	8
ILLINOIS FED. AID PROJECT			CONTRACT NO. 46196	