

**IL 21 – MILWAUKEE AVE.
EXISTING TYPICAL SECTION**

STA. 72+39 TO STA. 81+11
STA 83+64 TO STA 85+53
EXCLUDES NB RT TRN LN: STA 73+20 TO STA 76+68

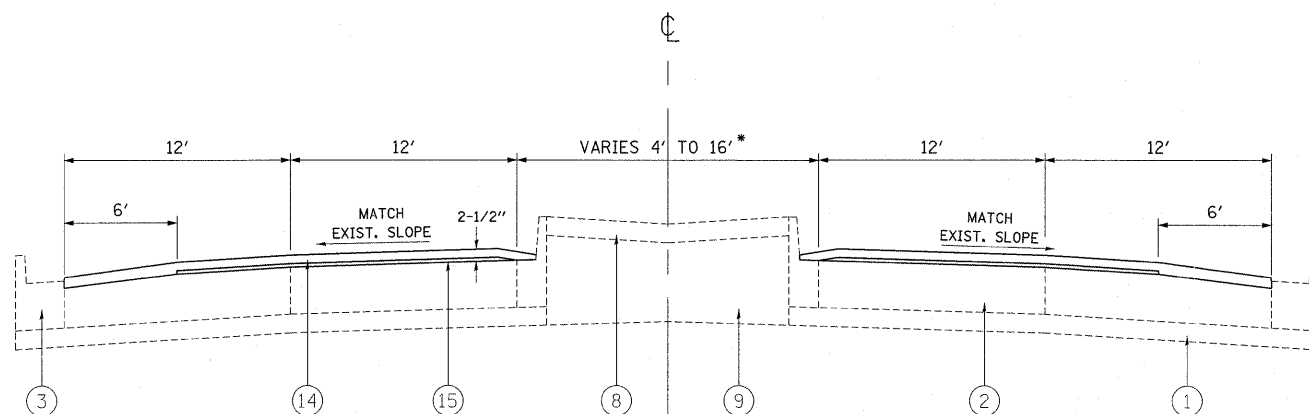

**IL 21 – MILWAUKEE AVE.
PROPOSED TYPICAL SECTION**

STA. 72+39 TO STA. 81+11
STA 83+64 TO STA 85+53
EXCLUDES NB RT TRN LN: STA 73+20 TO STA 76+68

LEGEND

- ① EXISTING STABILIZED SUB-BASE, 4"
- ② EXISTING PCC PAVEMENT, 10"±
- ③ EXISTING COMBINATION CONCRETE CURB AND GUTTER
- ④ EXISTING SB MEDIAN
- ⑤ EXISTING SM MEDIAN
- ⑥ EXISTING STABILIZED MEDIAN SURFACE, 12"
- ⑦ EXISTING CORRUGATED MEDIAN
- ⑧ EXISTING CONCRETE MEDIAN SURFACE, 4"
- ⑨ EXISTING SAND FILL
- ⑩ EXISTING TOP SOIL AND SODDING
- ⑪ PROPOSED MEDIAN REMOVAL PARTIAL DEPTH
- ⑫ PROPOSED HMA SURFACE REMOVAL, 2-1/2"
- ⑬ PROPOSED PCC SURFACE REMOVAL, VARIABLE DEPTH
- ⑭ PROPOSED POLYMERIZED HOT-MIX ASPHALT SURFACE COURSE, MIX "F", N90, 1-3/4"
- ⑮ PROPOSED POLYMERIZED LEVELING BINDER (MACHINE METHOD), IL-4.75, N50, 3/4"
- ⑯ PROPOSED PARTIAL DEPTH REMOVAL, 3"
- ⑰ PROPOSED HMA BINDER COURSE, IL-19.0, N70, 3"
(NOTE: FOR LONGITUDINAL JOINT REPAIR, SEE DETAIL ON SHEET #6)
- ⑱ PROPOSED MEDIAN REMOVAL
- ⑲ PROPOSED CLASS D PATCHES, TYPE IV, 10 INCH

OMISSION

STA. 81+11 TO STA. 83+64

THE CONTRACTOR SHALL PATCH FIRST BEFORE MILLING

NOTES:

- * AT LOCATIONS WHERE MEDIAN IS 4' WIDE THERE IS A 12' TRN LN

FILE NAME =	USER NAME = tariqfm	DESIGNED -	REVISED -	STATE OF ILLINOIS DEPARTMENT OF TRANSPORTATION	IL 21 (EUCLID AVE. TO GLENVIEW RD.) EXISTING AND PROPOSED TYPICAL SECTIONS				F.A.P. RTE.	SECTION	COUNTY	TOTAL SHEETS	SHEET NO.
et\pwork\pwork\tariqfm\0238476\0107	11-sh-t-plan.dgn	DRAWN -	REVISED -		374	211K-RS-1	COOK	27	7				
PLOT SCALE = 50.0000' / in.	CHECKED -	REVISED -			CONTRACT NO. 60M07								
PLOT DATE = 10/18/2011	DATE -	REVISED -			ILLINOIS FED. AID PROJECT								
					SCALE:	SHEET NO.	OF	SHEETS	STA.	TO STA.			