

CONCRETE REMOVAL PLAN

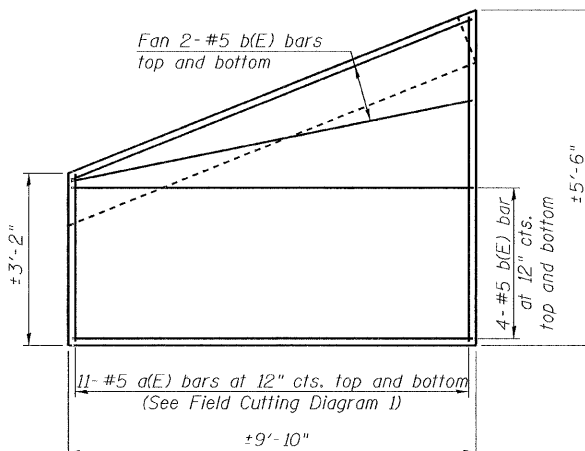

WIDENED APPROACH SLAB DETAIL

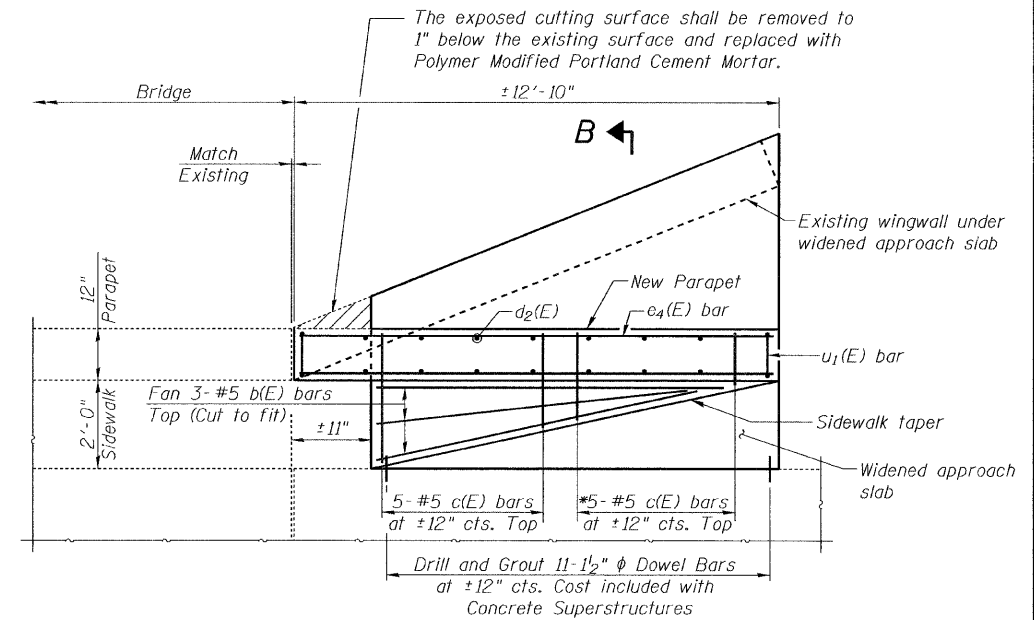

NEW END PARAPET PLAN

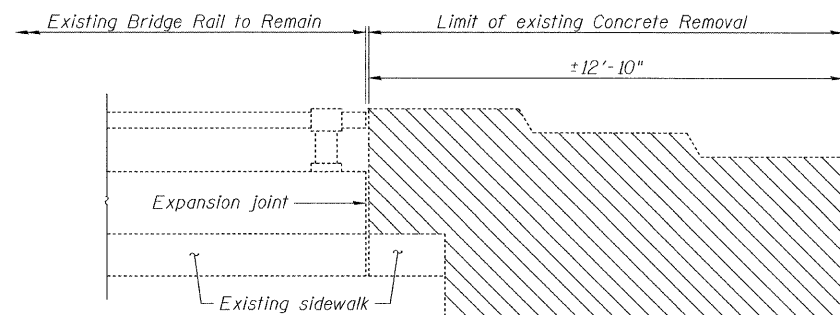

REMOVAL ELEVATION

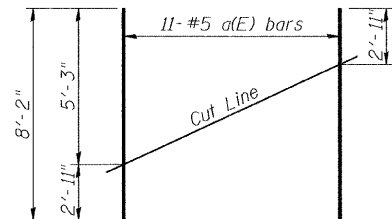

FIELD CUTTING DIAGRAM 1

Order a(E) full length. Cut as shown and use remainder of bars in bottom.

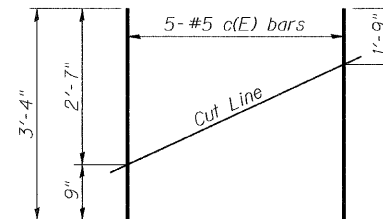

FIELD CUTTING DIAGRAM 2

Order c(E) full length. Cut as shown and use remainder of bars in other end.

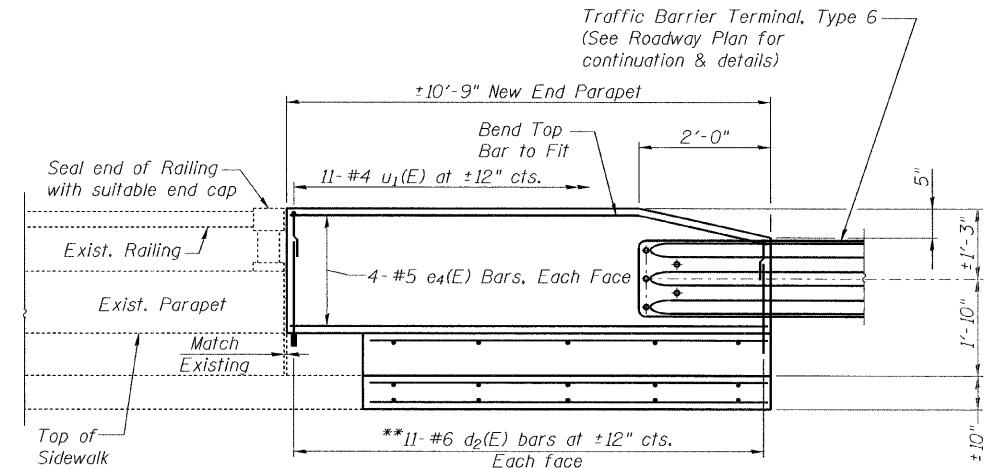

NEW END PARAPET ELEVATION

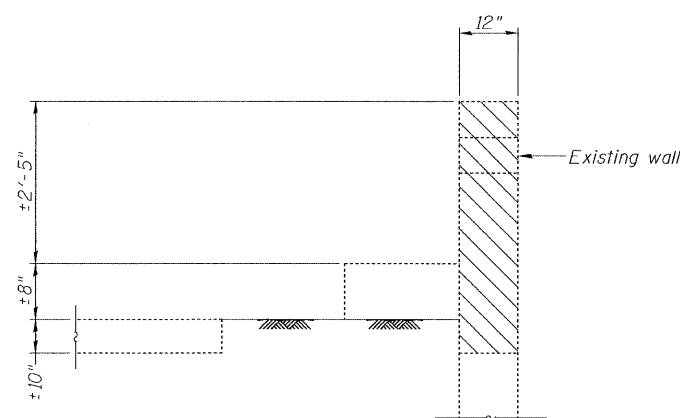

SECTION A-A

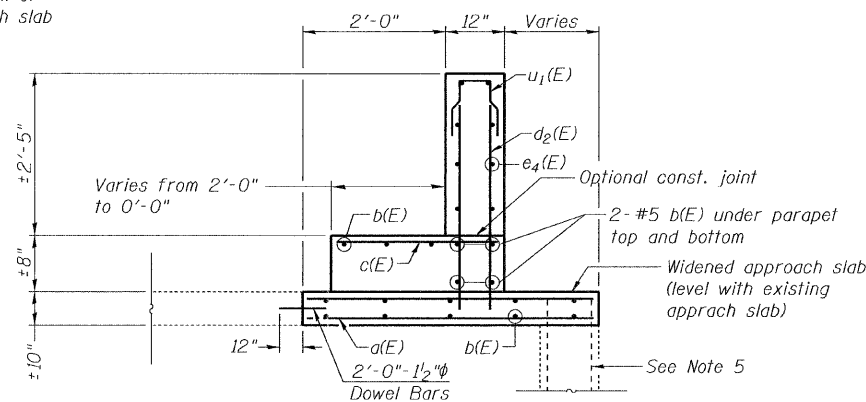

SECTION B-B

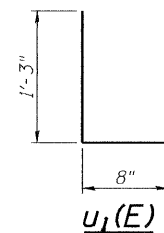

NOTES

1. Reinforcement bars shall conform to the requirements of ASTM A 706 Gr. 60. See Special Provisions.
2. Reinforcement bars designated (E) shall be epoxy coated.
3. Plan dimensions and details are developed from survey data. The Contractor shall field verify existing dimensions and details affecting new construction and make necessary approved adjustments prior to construction or ordering of materials. Such variations shall not be cause for additional compensation for a change in scope of the work, however, the Contractor will be paid for the quantity actually furnished at the unit price bid for the work.
4. Drilling and grouting bars shall be in accordance with Section 584 of the Standard Specifications.
5. Existing reinforcement shall be cleaned and incorporated into the new construction. Cost included with Concrete Removal.

BILL OF MATERIAL

Bar	No.	Size	Length	Shape
a(E)	14	#5	8'-2"	—
b(E)	24	#5	9'-7"	—
c(E)	6	#5	3'-4"	—
d2(E)	28	#6	3'-0"	—
e4(E)	10	#5	10'-6"	—
u1(E)	14	#4	3'-2"	□
Concrete Removal			Cu. Yd.	1.5
Concrete Superstructure			Cu. Yd.	3.3
Reinforcement Bars, Epoxy Coated			Pound	645
Polymer Modified Portland Cement Mortar			Sq. Ft.	0.75
Protective Coat			Sq. Yd.	14.2

* See Field Cutting Diagram 2
 ** Drill and grout d2(E) bars into the portion of the existing sidewalk to remain in place.

n:\jobs\2011\20110302-04\CAD\Site\ogn\00\DI60M66-sht-Parapet102.dgn
 1/3/2011 3:52:51 PM

GRAEF
 8501 N. Higgins Road, Suite 200
 Chicago, Illinois 60631, (773) 399-0112

USER NAME =	DESIGNED - X.X.X. 11/10/2011	REVISED -
PLOT SCALE =	CHECKED - X.X.X. 11/10/2011	REVISED -
PLOT DATE =	DRAWN - X.X.X. 11/10/2011	REVISED -
	CHECKED - X.X.X. 11/10/2011	REVISED -

**STATE OF ILLINOIS
 DEPARTMENT OF TRANSPORTATION**

**END PARAPET RECONSTRUCTION
 IL 56 OVER ROOSEVELT ROAD**

SHEET NO. 2 OF 2 SHEETS

F.A. RTE.	SECTION	COUNTY	TOTAL SHEETS	SHEET NO.
*	2010-119-GRR	DUPAGE	17	14
* VARIOUS ROUTES			CONTRACT NO. 60M56	
ILLINOIS FED. AID PROJECT				