

LEGEND

- ① EXIST. HOT-MIX ASPHALT BASE COURSE, 8''(±)
- ② EXIST. HOT-MIX ASPHALT SURFACE (BEFORE MILLING), 7''(±)
- ③ EXIST. CONCRETE CURB AND GUTTER TYPE B-6.24
- ④ EXIST. CONCRETE CURB AND GUTTER TYPE M-2.12
- ⑤ EXIST. STABILIZED MEDIAN 12''(±)
- ⑥ EXIST. SUBBASE GRANULAR MATERIAL 4''(±)
- ⑦ PROP. HOT-MIX ASPHALT SURFACE REMOVAL - 2 1/2''
- ⑧ PROP. POLYMERIZED HOT-MIX ASPHALT SURFACE COURSE, MIX "F", N90, 1 3/4''
- ⑨ PROP. POLYMERIZED LEVELING BINDER (MM), IL-4.75, N50, 3/4''
- ⑩ PROP. CONCRETE CURB AND GUTTER REMOVAL AND REPLACEMENT (LOCATIONS TO BE DETERMINED BY THE RESIDENT ENGINEER)

NOTES:

1. SEE ROADWAY AND PAVEMENT MARKING PLAN SHEETS FOR LOCATIONS OF LEFT TURN LANES AND PAINTED MEDIANS.
2. MILLING OF THE ROADWAY SHALL BE DONE PRIOR TO PAVEMENT PATCHING.

HOT-MIX ASPHALT MIXTURE REQUIREMENTS

	MIXTURE TYPE	AIR VOIDS (%)
ROADWAY	HOT-MIX ASPHALT SURFACE COURSE, MIX "D", N70, (IL-9.5MM), 1 1/2''	4% @ 70 GYR
	POLYMERIZED HOT-MIX ASPHALT SURFACE COURSE, MIX "F", N90, (IL-9.5MM), 1 3/4''	4% @ 90 GYR
	POLYMERIZED LEVELING BINDER (MM), IL-4.75, N50, 3/4''	4% @ 50 GYR
PATCHES	CLASS D PATCHES (HMA BINDER IL-19 mm)	4% @ 70 GYR

THE UNIT WEIGHT USED TO CALCULATE ALL HMA SURFACE MIXTURE QUANTITIES IS 112 LBS/SQ YD/IN.

THE "AC TYPE" FOR ALL POLYMERIZED HMA MIXES SHALL BE "SBS/SBR PG 70-22 AND FOR NON-POLYMERIZED HMA THE "AC TYPE" SHALL BE PG 64-22" UNLESS MODIFIED BY DISTRICT ONE SPECIAL PROVISIONS. FOR "PERCENT OF RAP" SEE DISTRICT ONE SPECIAL PROVISIONS.

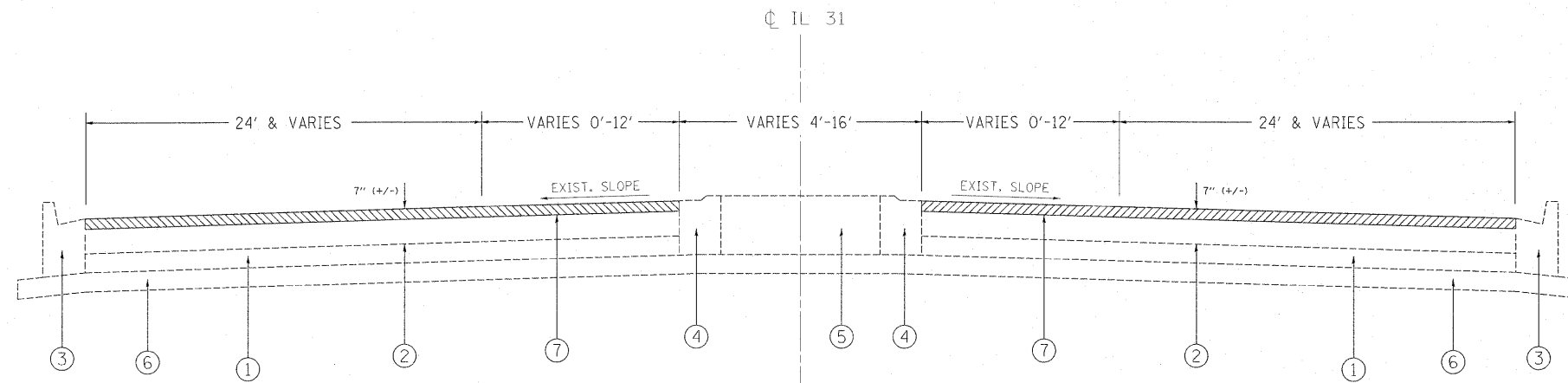

**EXISTING TYPICAL SECTION
IL 31
STATION:
354+00 TO 372+82
391+29 TO 420+18**

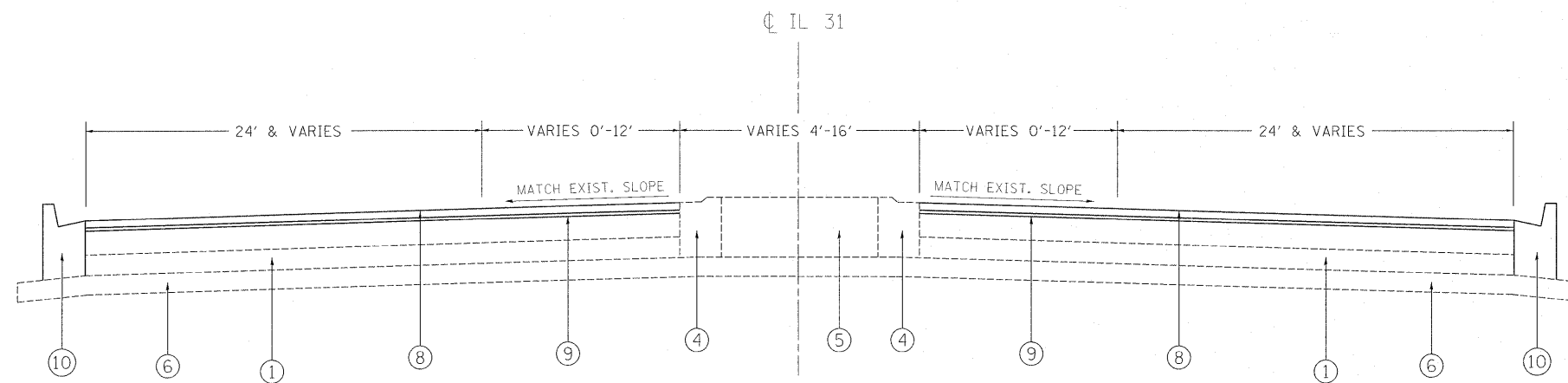

**PROPOSED TYPICAL SECTION
IL 31
STATION:
354+00 TO 372+82
391+29 TO 420+18**