

NOTE: COMPOSITE PAVER TILE USED SHALL BE AS MANUFACTURED BY ADA SOLUTIONS, INC., OR AN APPROVED EQUAL, AS APPROVED BY THE ENGINEER.

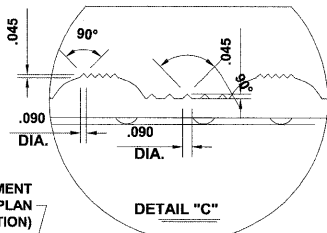

**CAST-IN-PLACE COMPOSITE PAVER TILE FOR DETECTABLE WARNING**

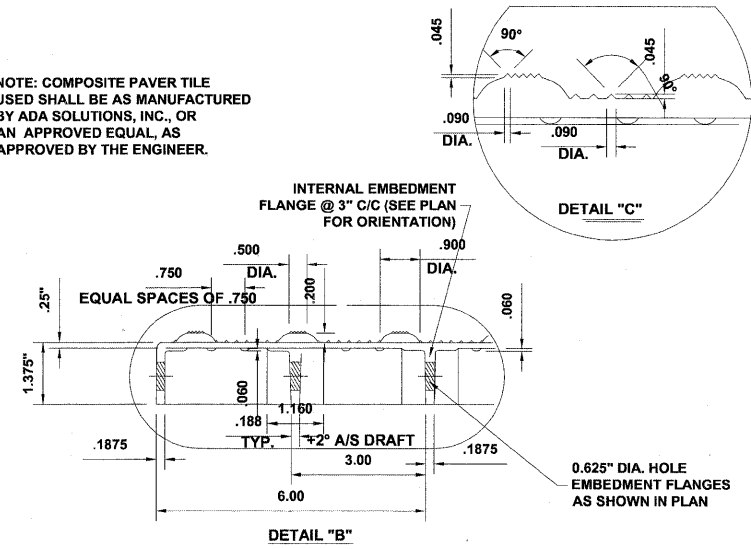
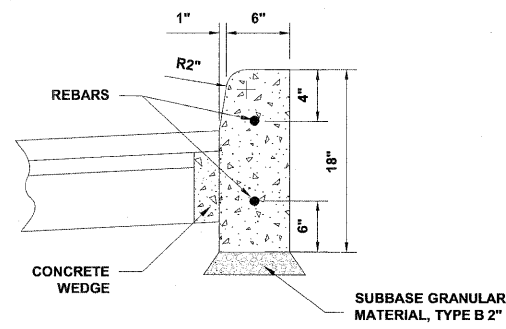

**CONCRETE CURB, TYPE B**

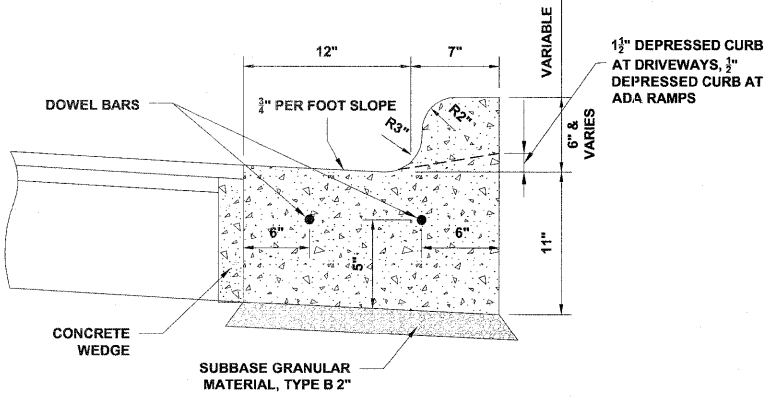

**COMBINATION CONCRETE CURB & GUTTER TYPE B-6.12 (SPECIAL)**

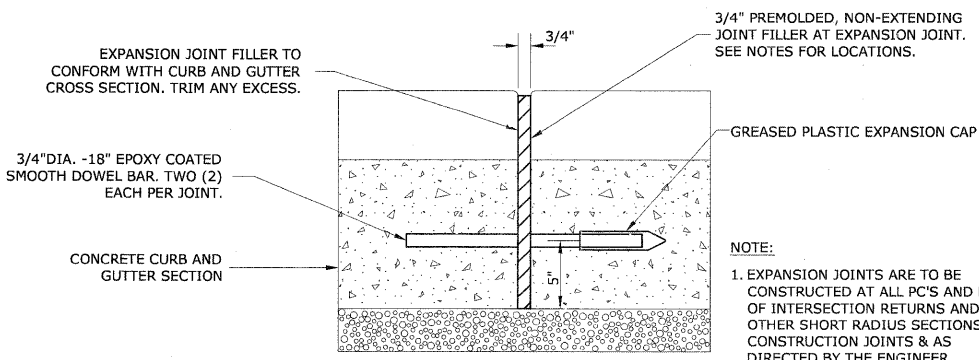

**TYPICAL CURB AND GUTTER EXPANSION JOINT**

NOTE:  
1. EXPANSION JOINTS ARE TO BE CONSTRUCTED AT ALL PC'S AND PT'S OF INTERSECTION RETURNS AND ALL OTHER SHORT RADIUS SECTIONS, CONSTRUCTION JOINTS & AS DIRECTED BY THE ENGINEER.

**CONCRETE GENERAL NOTES**

**DEPRESSED CURBS** - THE TOP OF CURBS SHALL BE DEPRESSED WHERE THE CURB AND GUTTER IS CONSTRUCTED AT HANDICAP ACCESSIBLE SIDEWALK RAMP AT ALLEY RETURNS AND STREET INTERSECTIONS, AND FOR PRIVATE DRIVES AND AS DIRECTED BY THE ENGINEER. THE HEIGHT OF THE DEPRESSED CURB SHALL BE 1-1/2" AT DRIVEWAYS. SEE IDOT STANDARD 424001-06 FOR HEIGHT AT SIDEWALK RAMP.

**DRAINAGE OPENINGS** - AT ALL LOCATIONS WHERE CASTINGS ARE TO BE INCORPORATED IN THE CURB AND GUTTER, A 3/4" EXPANSION JOINT SHALL BE INSTALLED IN THE CURB AND GUTTER A DISTANCE OF 5 FT. FROM EACH SIDE OF THE CASTING. 2-NO. 4 RE-BARS, 9' IN LENGTH, SHALL BE INCORPORATED IN THE CONTINUOUS PORTION OF CONCRETE CURB BEHIND THE CASTING.

**SLIPFORM CONSTRUCTION** - VERTICAL FACES MAY BE BATTERED AT THE RATE OF 3/4" PER FOOT OF HEIGHT TO AID IN SLIPFORM OPERATIONS.

**CURB AND GUTTER REMOVAL**

THE COSTS FOR REMOVAL OF ANY ASPHALT OVERLAY THAT EXTENDS INTO THE GUTTER PORTION OF THE CURB AND GUTTER WILL BE INCLUDED IN THE PRICE FOR COMBINATION CURB AND GUTTER REMOVAL.

**FORMS FOR CONCRETE SIDEWALKS, DRIVEWAYS, AND GUTTER FLAGS**

A 2" X 6" BOARD WILL BE USED AS A FORM FOR ALL SIDEWALKS TO BE INSTALLED FIVE INCHES (5") IN THICKNESS. A 2" X 8" BOARD WILL BE USED AS A FORM FOR ALL SIDEWALKS AND DRIVEWAYS TO BE INSTALLED SEVEN INCHES (7") IN THICKNESS. ALL FORMS MUST BE OF A MINIMUM HEIGHT OF THE PROPOSED THICKNESS OF THE RESPECTIVE CONCRETE ITEMS TO BE INSTALLED.

**AGGREGATE BEDDING FOR CONCRETE WORK**

NEW SIDEWALK AND DRIVEWAY PAVEMENT SHALL BE REPLACED ON A MINIMUM OF TWO INCHES (2") OF COMPACTED CA-6 STONE BEDDING. ADDITIONAL AGGREGATE REQUIRED TO ADJUST THE EXISTING ELEVATION OF THE SUBGRADE TO THE PROPOSED ELEVATION WILL BE INCLUDED AS PART OF THIS WORK.

**BASIS OF PAYMENT** : THIS ITEM WILL NO BE PAID FOR SEPARATELY BUT WILL BE INCLUDED IN THE UNIT PRICE FOR THE RESPECTIVE CONCRETE ITEMS IN THE CONTRACT.

**CURING AND PROTECTION**

AFTER THE CONCRETE HAS BEEN FINISHED AND THE WATER SHEEN HAS DISAPPEARED FROM THE SURFACE OF THE CONCRETE, THE SURFACE SHALL BE SEALED WITH A MEMBRANE CURING COMPOUND OF A TYPE APPROVED BY THE ENGINEER. THE SEAL SHALL BE MAINTAINED FOR THE SPECIFIED CURING PERIOD. THE EDGES OF THE CONCRETE SHALL ALSO BE SEALED IMMEDIATELY AFTER THE FORMS ARE REMOVED. IN ADDITION, ALL CONCRETE PLACED DURING PERIODS OF COLD WEATHER SHALL BE PROTECTED IN ACCORDANCE WITH ARTICLE 720.13 OF THE STANDARD SPECIFICATIONS. THIS WORK SHALL BE CONSIDERED INCLUDED IN THE RESPECTIVE CONCRETE PAY ITEMS.

THE WORK SHALL BE UNDER THE CHARGE AND CARE OF THE CONTRACTOR UNTIL FINAL ACCEPTANCE BY THE VILLAGE. THE CONTRACTOR SHALL ASSUME ALL RESPONSIBILITY FOR ANY INJURY OR DAMAGE TO THE WORK FROM ANY CAUSE WHATSOEVER AND HE SHALL REBUILD, REPAIR OR RESTORE THE DAMAGED WORK AT HIS OWN EXPENSE.

**BASIS OF PAYMENT** : THIS ITEM WILL NOT BE PAID FOR SEPARATELY BUT WILL BE INCLUDED IN THE UNIT PRICE FOR THE VARIOUS CONCRETE ITEMS IN THE CONTRACT.

**PROTECTION OF NEWLY POURED CONCRETE**

THE CONTRACTOR SHALL HAVE WATCHMEN AT THE JOB SITE AFTER CONCRETE HAS BEEN POURED UNTIL THE CONCRETE HAS CURED SUFFICIENTLY SO THAT NO GRAFFITI CAN BE INSCRIBED IN THE NEWLY POURED CONCRETE SURFACES. THE EXPOSED FACES OF CONCRETE OF ANY ITEMS THAT ARE DEFACED SHALL BE REPLACED BY THE CONTRACTOR AT HIS OWN EXPENSE.

**BITUMINOUS EXPANSION JOINTS**

THREE-QUARTER INCH (3/4") BITUMINOUS PREMOLDED INORGANIC FIBER EXPANSION JOINTS SHALL BE INSTALLED WHERE NEW SIDEWALK OR CURB AND GUTTER OR DRIVEWAY PAVEMENT ABUTS AN EXISTING CONCRETE WALK, DRIVE, OR CURB WHICH IS TO REMAIN IN PLACE, AND AT NOT LESS THAN FIFTY FOOT (50') INTERVALS AT LOCATIONS WHERE SIDEWALK REPLACEMENT IS IN EXCESS OF FIFTY FOOT (50'), AND AT LOCATIONS AS DIRECTED BY THE ENGINEER.

EXPANSION JOINTS WILL BE PLACED IN CURB AND GUTTER AT ALL RADIUS POINTS, ALL BEND POINTS, ON BOTH SIDES OF FRAMES AND GRATES THAT ARE IN THE CURB AND GUTTER, AND AT NOT LESS THAN NINETY FOOT (90') INTERVALS AT LOCATIONS WHERE CURB REPLACEMENT IS IN EXCESS OF NINETY FEET (90'), AND AT LOCATIONS AS DIRECTED BY THE ENGINEER.

ALL EXPANSION JOINTS LOCATED IN THE CURB AND GUTTER SHALL HAVE TWO (2) THREE QUARTER INCH (3/4") DIAMETER, SMOOTH, ROUND, EPOXY COATED DOWEL BARS, EIGHTEEN INCHES (18") IN LENGTH, WITH PLASTIC END CAPS INSERTED TO ALLOW THE CURB AND GUTTER TO EXPAND AND CONTRACT LATERALLY.

THIS WORK WILL NOT BE PAID FOR SEPARATELY BUT WILL BE INCLUDED IN THE COST OF THE INDIVIDUAL CONCRETE ITEMS.

**CONTRACTION JOINTS**

CONTRACTION JOINTS SHALL BE TOOLED INTO THE CURB AND GUTTER AT INTERVALS NOT TO EXCEED FIFTEEN FEET (15'). THESE CONTRACTION JOINTS SHALL BE SAW CUT TO A DEPTH OF TWO INCHES (2") WITHIN TWENTY-FOUR (24) HOURS OF CONCRETE PLACEMENT. THE COST OF THE ABOVE WORK SHALL BE INCLUDED IN THE RESPECTIVE ITEMS FOR CONCRETE INSTALLATION.

**CONTINUOUS REINFORCEMENT**

PROVIDE 2 - 1/2" DIAMETER (NO. 4) REBARS THROUGH ENTIRE CURB LENGTH, LAP SPLICED FOR ALL BARRIER CURB.

**CONCRETE WEDGE**

A LEAN CONCRETE WEDGE IS TO BE POURED IN THE SPACE BETWEEN THE NEW CURB & THE EXISTING PAVEMENT AFTER THE CURB HAS REACHED ITS INITIAL SET.

Drawing file: W:\Projects\60011046 - Division Street IEP\DETAILS.dwg Nov. 10, 2011 - 9:11am



Civil Engineers  
Municipal Consultants  
Established 1911

9533 Boonville Road  
Woodstock, Illinois 60154-2709  
Phone: 708/645-6396  
Fax: 708/645-1312

DESIGNED - ELS	REVISED -
DRAWN - MK, DMM	REVISED -
CHECKED - ELS	REVISED -
DATE - 11-02-11	REVISED -

STATE OF ILLINOIS  
DEPARTMENT OF TRANSPORTATION

ROADWAY DETAILS

SCALE: NONE SHEET NO. 1 OF 2 SHEETS STA. TO STA.

F.A.U. RTE.	SECTION	COUNTY	TOTAL SHEETS	SHEET NO.
1026	10-00116-00-SW	COOK	40	6
FED. ROAD DIST. NO. 1 ILLINOIS			CONTRACT NO. 63654	
FED. AID PROJECT M-TE-00D1(825)			EHE PROJECT NO. 600-11-04602	