

Notes:
 See sheet 25 of 48 for Detail A and View B-B.
 Approach slab and parapet concrete shall be paid for as Concrete Superstructure.
 Approach footing concrete shall be paid for as Concrete Structures.
 Reinforcement shall be paid for as Reinforcement Bars, Epoxy Coated.
 For v(E) bar details, see sheet 28 of 48.
 The approach footing maximum applied service bearing pressure (Q_{max}) = 2.0 ksf.
 For bar splicer details, see sheet 42 of 48.
 Cost of excavation for approach footing included with Concrete Structures.
 For Porous Granular Embankment (Special) and drainage treatment details, see sheet 2 of 48.
 For additional parapet details, see sheet 17 of 48.

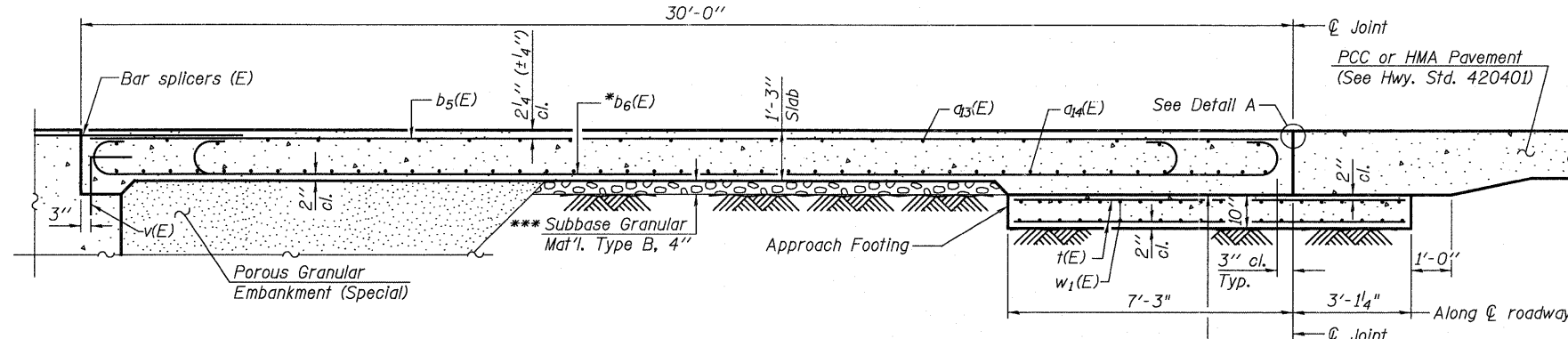

SECTION C-C

* Tilt #9 $b_6(E)$ bars as required to maintain clearance.
 *** Cost included with Concrete Superstructure.

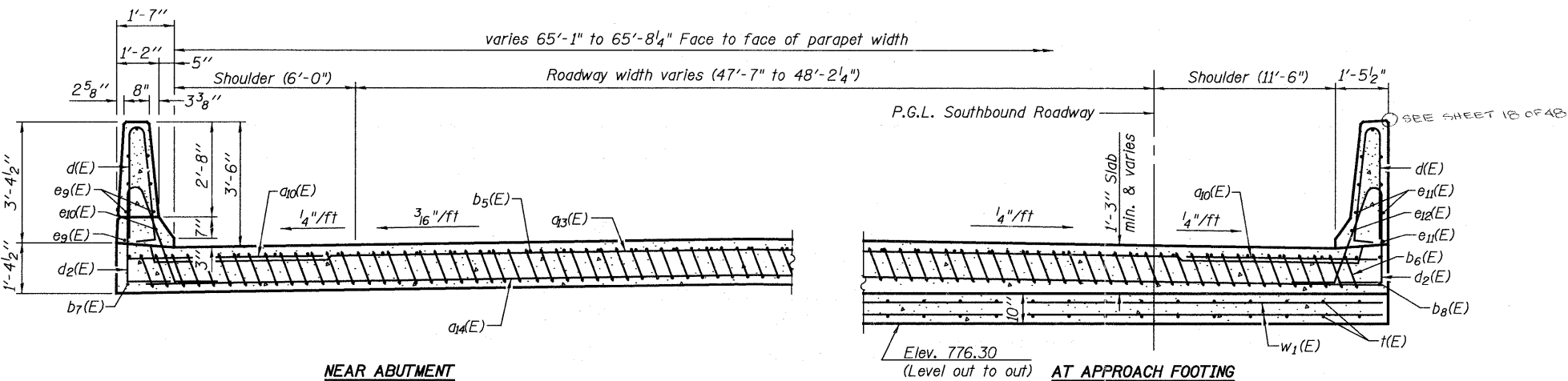

SECTION G-G

(See Plan for dimensions not shown)

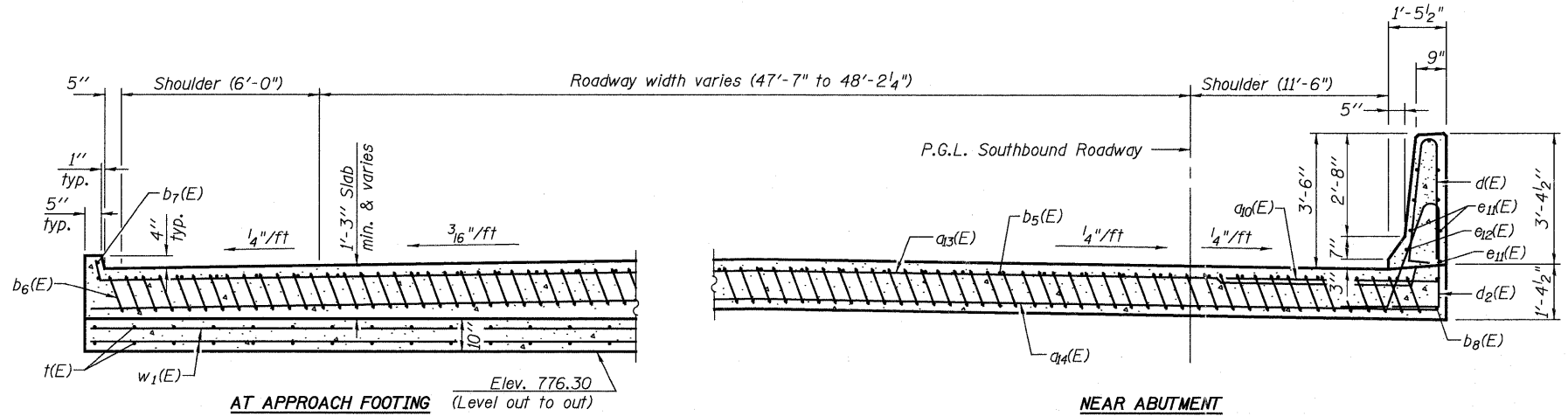

SECTION D-D

(See Plan for dimensions not shown)

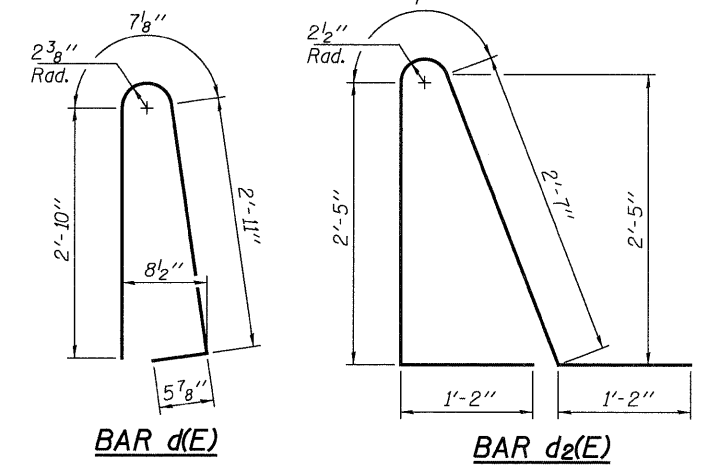

BAR d(E)

BAR d2(E)

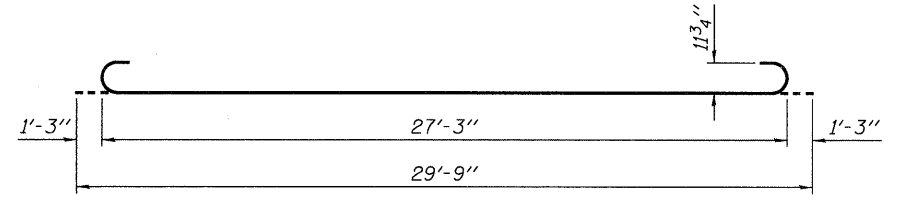

BAR b6(E)

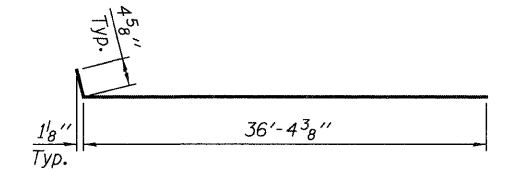

BAR a3(E)

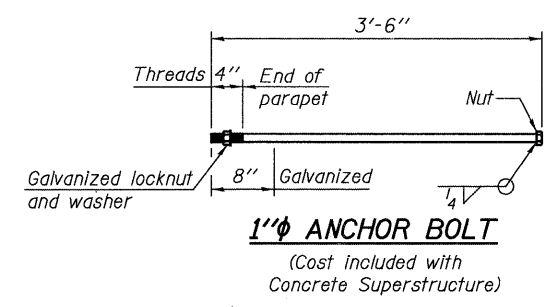

1" ANCHOR BOLT

(Cost included with Concrete Superstructure)

BILL OF MATERIAL

Bar	No.	Size	Length	Shape
$a_{10}(E)$	36	#6	6'-6"	—
$a_3(E)$	50	#4	36'-9"	—
$a_4(E)$	92	#5	36'-6"	—
$b_5(E)$	53	#4	29'-8"	—
$b_6(E)$	156	#9	29'-9"	—
$b_7(E)$	2	#4	14'-8"	—
$b_8(E)$	1	#4	29'-8"	—
$d(E)$	50	#5	6'-10"	U
$d_2(E)$	50	#5	7'-11"	U
$e_9(E)$	8	#4	14'-8"	—
$e_{10}(E)$	1	#8	14'-8"	—
$e_{11}(E)$	8	#4	29'-8"	—
$e_{12}(E)$	1	#8	29'-8"	—
$t(E)$	132	#4	10'-0"	—
$w_1(E)$	80	#5	35'-9"	—
Concrete Superstructure			Cu. Yd.	107.0
Concrete Structures			Cu. Yd.	20.4
Reinforcement Bars, Epoxy Coated			Pound	26,940

LAP LENGTH

#4 bars = 2'-1"
 #5 bars = 2'-7"

(Sheet 2 of 2)



USER NAME =	DESIGNED - JTT	REVISOR -
PLLOT SCALE =	CHECKED - VAC	REVISIONS -
PLLOT DATE =	DRAWN - JBB	REVISIONS -
	CHECKED - JTT	REVISIONS -

**STATE OF ILLINOIS
 DEPARTMENT OF TRANSPORTATION**

**BRIDGE APPROACH SLAB DETAILS S.W.
 STRUCTURE NO. 101-0193**

BRIDGE SHEET NO. 26 OF 48 SHEETS

F.A.I. RTE.	SECTION	COUNTY	TOTAL SHEETS	SHEET NO.
90	(X2)-1R	WINNEBAGO	510	371
			CONTRACT NO. 64C29	

ILLINOIS FED. AID PROJECT