

SECTION A-A FOR EX EARTH/AGGREGATE PE, FE
(NO PROPOSED ENTRANCE WORK)

LOCATIONS OF ENTRANCES:

STA. 153+32 LT	STA. 101+25 RT
STA. 355+75 LT	STA. 103+37 RT
STA. 380+15 LT	STA. 104+33 RT
	STA. 153+87 RT
	STA. 218+50 RT
	STA. 245+05 RT
	STA. 283+00 RT
	STA. 338+50 RT
	STA. 350+10 RT
	STA. 357+35 RT
	STA. 424+35 RT

GENERAL NOTES:

THE RESIDENT ENGINEER WILL DETERMINE THE EXACT TYPE OF IMPROVEMENT TO BE COMPLETED FOR ALL ENTRANCES, SIDEROADS AND MAILBOX TURNOUTS ON THIS PROJECT.

THE PLAN DETAILS AND SCHEDULES SHOULD BE USED AS A GUIDE FOR THE ENGINEER TO IMPLEMENT THE FINAL DESIGN. THE ENGINEER MAY DECIDE TO SALVAGE PORTIONS OF THE EXISTING ENTRANCE PAVEMENT STRUCTURE; THEREFORE, REDUCING PAY ITEM QUANTITIES. NO ADDITIONAL PAYMENT WILL BE ALLOWED FOR THIS REDUCTION IN QUANTITIES.

ANY WORK THE ENGINEER REQUIRES WHICH IS NOT COVERED BY A PAY ITEM CONTAINED IN THE PLANS WILL BE PAID FOR IN ACCORDANCE WITH ARTICLE 109.04 OF THE STANDARD SPECIFICATIONS.

HOT-MIX ASPHALT REQUIRED TO CONSTRUCT THE ENTRANCES SHALL BE IN ACCORDANCE WITH THE APPLICABLE PORTIONS OF SECTION 406 AND 408 OF THE STANDARD SPECIFICATIONS AND AS DIRECTED BY THE ENGINEER.

WHEN THE HOT-MIX ASPHALT PROPOSED FOR THE IMPROVEMENT IS THICKER THAN 75 mm (3 INCHES) AND REQUIRE PLACEMENT IN MORE THAN ONE LIFT, THE BOTTOM LIFT(S) SHALL MEET THE REQUIREMENTS OF HMA BASE COURSE IN SECTION 406 OF THE STANDARD SPECIFICATIONS AND THE TOP LIFT OF 50 mm (2 INCHES) SHALL MEET THE REQUIREMENTS OF INCIDENTAL HOT-MIX ASPHALT SURFACING.

THIS WORK WILL BE PAID FOR IN ACCORDANCE WITH SECTIONS 351, 358, 408, 423 AND 440 OF THE STANDARD SPECIFICATIONS.

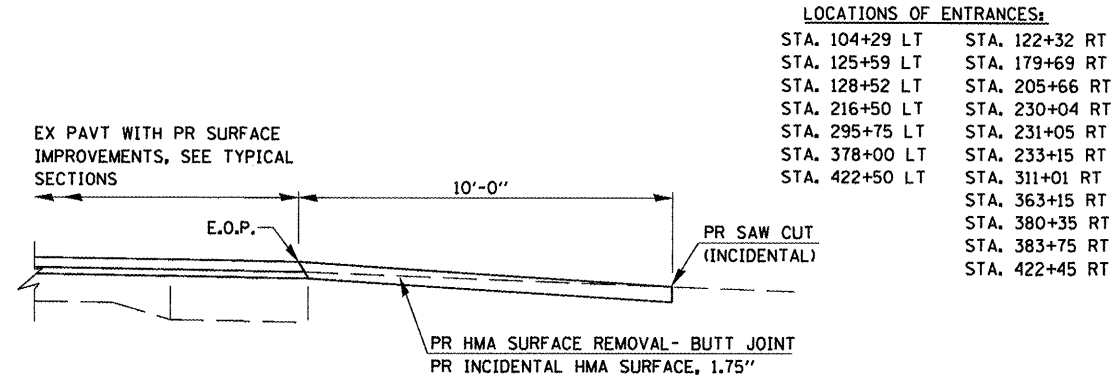
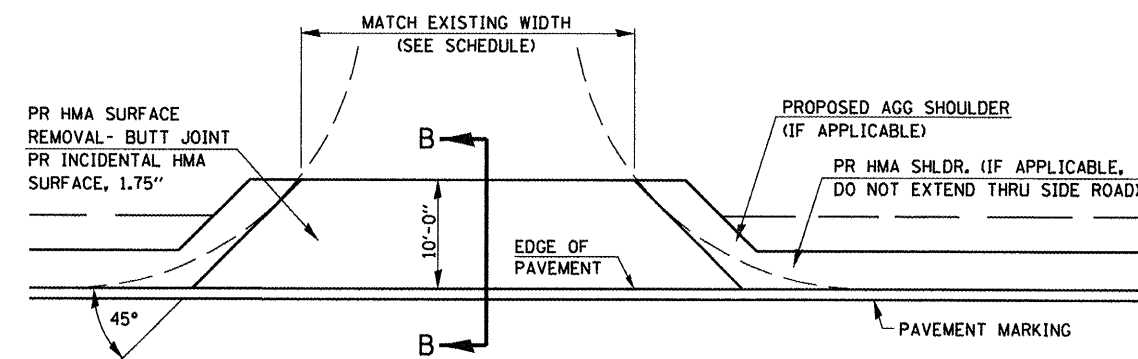

SECTION B-B FOR HMA CE, PE, & SIDE ROAD

LOCATIONS OF ENTRANCES:

STA. 104+29 LT	STA. 122+32 RT
STA. 125+59 LT	STA. 179+69 RT
STA. 128+52 LT	STA. 205+66 RT
STA. 216+50 LT	STA. 230+04 RT
STA. 295+75 LT	STA. 231+05 RT
STA. 378+00 LT	STA. 233+15 RT
STA. 422+50 LT	STA. 311+01 RT
	STA. 363+15 RT
	STA. 380+35 RT
	STA. 383+75 RT
	STA. 422+45 RT

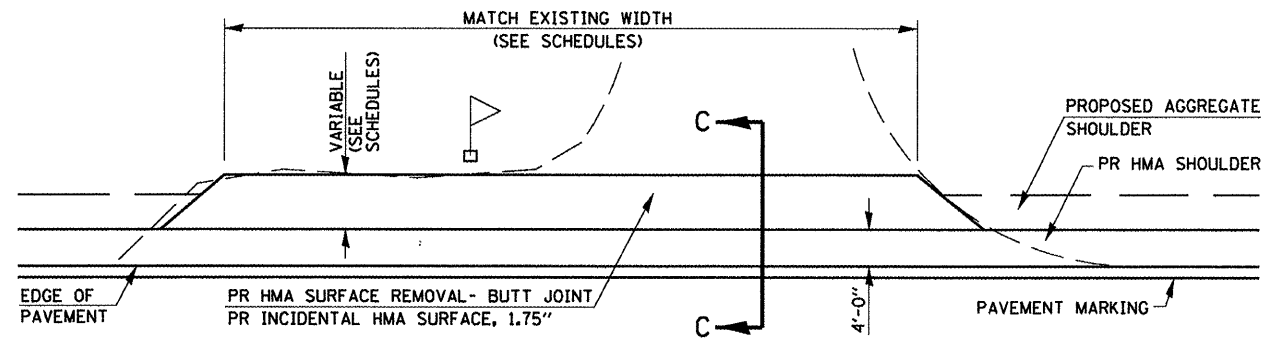

ENTRANCE WITH TRAILING SIDE MAILBOX

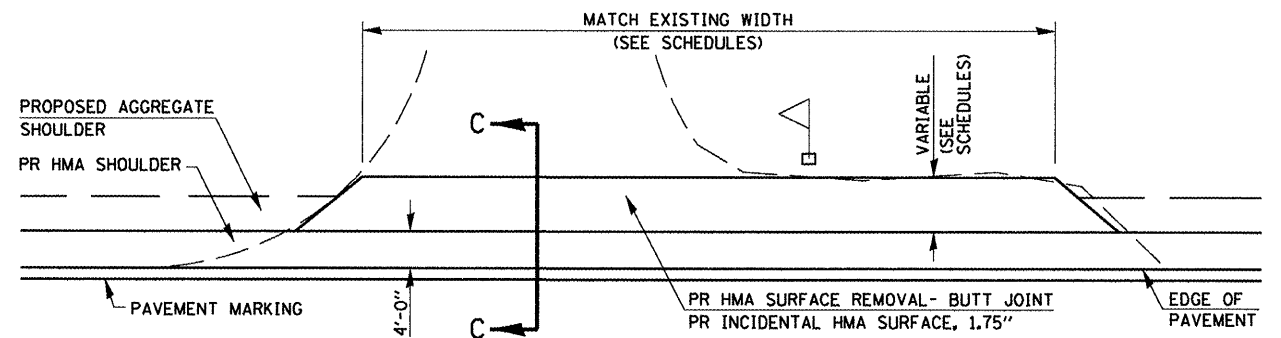

ENTRANCE WITH LEADING SIDE MAILBOX

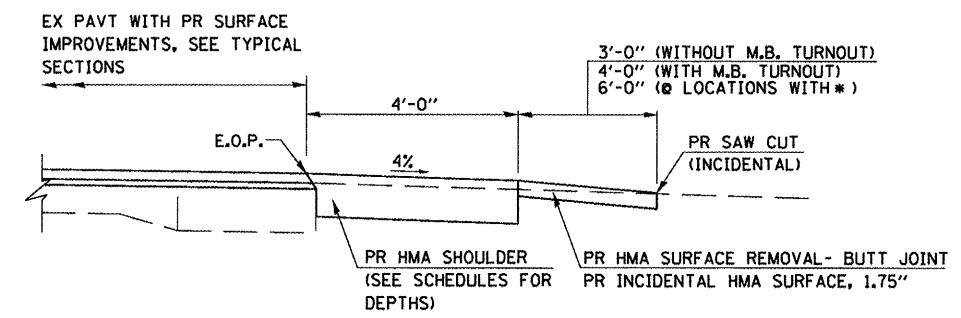

SECTION C-C FOR EX HMA PE
(WITH OR WITHOUT MAILBOX TURNOUT)

LOCATIONS OF ENTRANCES:

STA. 184+53 LT	STA. 109+68 RT
STA. 184+86 LT	STA. 125+59 RT
STA. 192+89 LT	STA. 128+52 RT
STA. 205+66 LT	STA. 132+46 RT
STA. 206+80 LT	STA. 177+23 RT *
STA. 223+50 LT	STA. 184+81 RT
STA. 243+12 LT *	STA. 190+18 RT
STA. 245+10 LT	STA. 192+58 RT
STA. 246+20 LT	STA. 194+37 RT
STA. 253+12 LT	STA. 197+70 RT
STA. 269+45 LT	STA. 258+65 RT
STA. 274+25 LT	STA. 268+50 RT
STA. 425+76 LT	STA. 271+80 RT
	STA. 292+05 RT
	STA. 295+75 RT
	STA. 307+00 RT
	STA. 326+51 RT

-- 325, 42
 ** (15, 21)RS-7, 22RS-4, 24RS-8

FILE NAME =	USER NAME = sparksgw	DESIGNED - RTS	REVISED -	STATE OF ILLINOIS DEPARTMENT OF TRANSPORTATION	ENTRANCE DETAILS	F.A.P. RTE.	SECTION	COUNTY	TOTAL SHEETS	SHEET NO.	
c:\pwork\pwork\sparksgw\d2222085\0672067-sht-details.dgn		DRAWN - RTS	REVISED -			*	**	MONTGOMERY	80	70	
PLOT SCALE = 200.0000' / in.		CHECKED -	REVISED -			CONTRACT NO.					
PLOT DATE = Aug-25-2011 10:16:21AM		DATE - 06-16-11	REVISED -			FED. ROAD DIST. NO. ILLINOIS FED. AID PROJECT					
					SCALE:	SHEET NO. 1 OF 2 SHEETS	STA.	TO STA.			