

**STANDARD BAR SPLICER ASSEMBLY**

Bar size to be spliced	Minimum Lap Lengths				
	Table 1	Table 2	Table 3	Table 4	Table 5
3, 4	1'-5"	1'-11"	2'-1"	2'-4"	2'-3"
5	1'-9"	2'-5"	2'-7"	2'-11"	2'-10"
6	2'-1"	2'-11"	3'-1"	3'-6"	3'-4"
7	2'-9"	3'-10"	4'-2"	4'-8"	4'-6"
8	3'-8"	5'-1"	5'-5"	6'-2"	5'-10"
9	4'-7"	6'-5"	6'-10"	7'-9"	7'-5"

- Table 1: Black bar, 0.8 Class C
- Table 2: Black bar, Top bar lap, 0.8 Class C
- Table 3: Epoxy bar, 0.8 Class C
- Table 4: Epoxy bar, Top bar lap, 0.8 Class C
- Table 5: Epoxy bar, Top bar lap, Class B

Threaded splicer bar length = min. lap length + 1/2" + thread length

\* Epoxy not required on Bar Splicer Assembly components used in conjunction with black bars.

Location	Bar size	No. assemblies required	Table for minimum lap length
Deck	#5	20	3
Abutments	#6	8	3

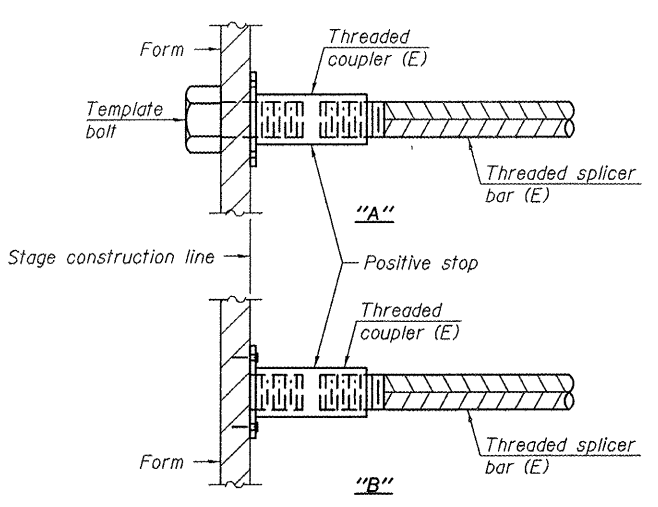

**INSTALLATION AND SETTING METHODS**

"A" : Set bar splicer assembly by means of a template bolt.  
 "B" : Set bar splicer assembly by nailing to wood forms or cementing to steel forms.  
 (E) : Indicates epoxy coating.

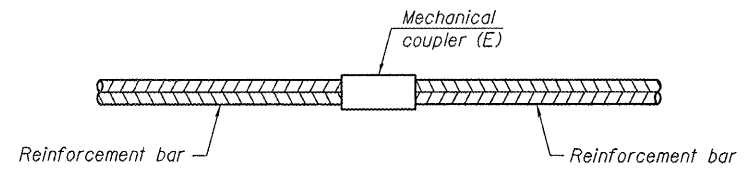

**STANDARD MECHANICAL SPLICER**

Location	Bar size	No. assemblies required

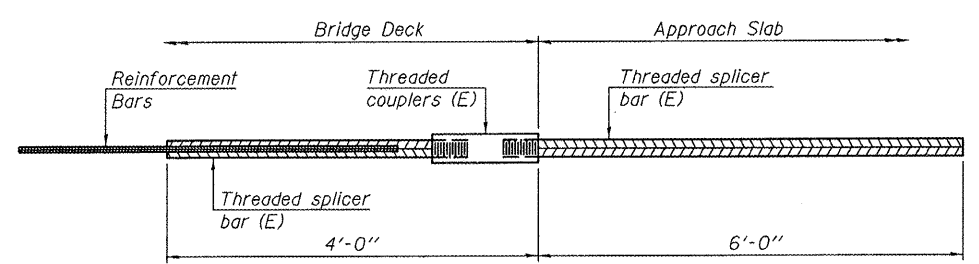

**BAR SPLICER ASSEMBLY FOR #5 BAR ON INTEGRAL OR SEMI-INTEGRAL ABUTMENTS**

No. required =

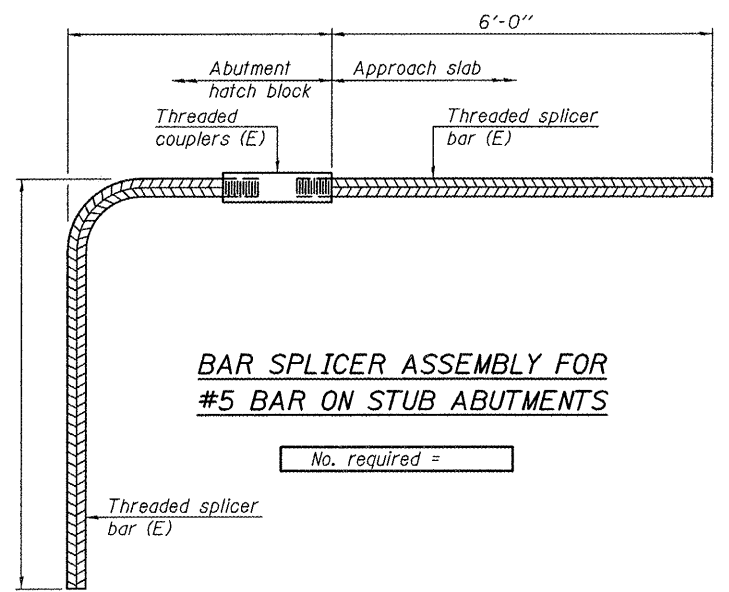

**BAR SPLICER ASSEMBLY FOR #5 BAR ON STUB ABUTMENTS**

No. required =

**NOTES**

Splicer bars shall be deformed with threaded ends and have a minimum 60 ksi yield strength.  
 All reinforcement shall be lapped and tied to the splicer bars.  
 Bar splicer assemblies shall be epoxy coated according to the requirements for reinforcement bars. See Section 508 of the Standard Specifications.  
 See special provision for Mechanical Splicers.  
 See approved list of bar splicer assemblies and mechanical splicers for alternatives.

BSD-1

7-1-10

DESIGNED - IJL	EXAMINED - <i>Joanne F. J...</i>	DATE - NOVEMBER 28, 2011
CHECKED - ADY	PASSED - <i>J. Carl...</i>	
DRAWN - Kyle M. Steffen		
CHECKED - IJL ADY		

STATE OF ILLINOIS  
 DEPARTMENT OF TRANSPORTATION

BAR SPLICER ASSEMBLY AND MECHANICAL SPLICER DETAILS  
 SN 075-0080  
 SHEET NO. 5 OF 5 SHEETS

F.A.P. RTE.	SECTION	COUNTY	TOTAL SHEETS	SHEET NO.
321	104RS2, BR3;	PIKE	69	69
	105RS7, BR3, 4; 106RS6			
ILLINOIS FED. AID PROJECT				