

**ANCHOR BOLT LAYOUT**

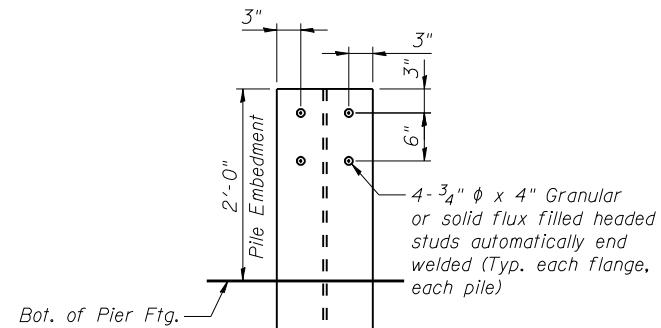

**DETAIL A**

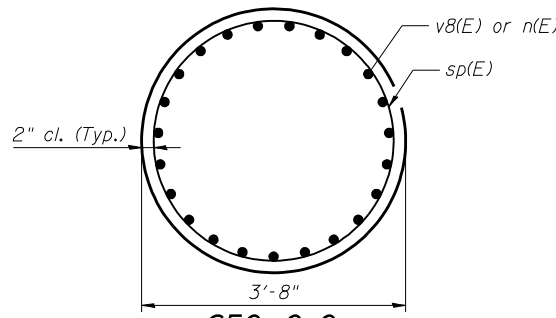

**SEC. C-C**

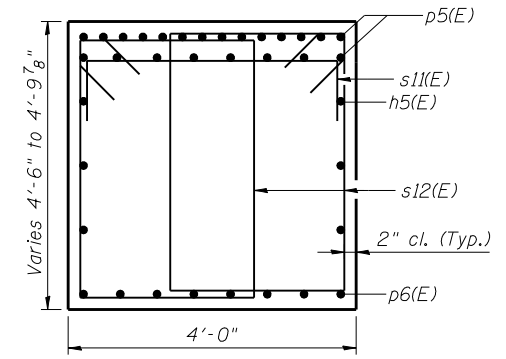

**SEC. A-A**

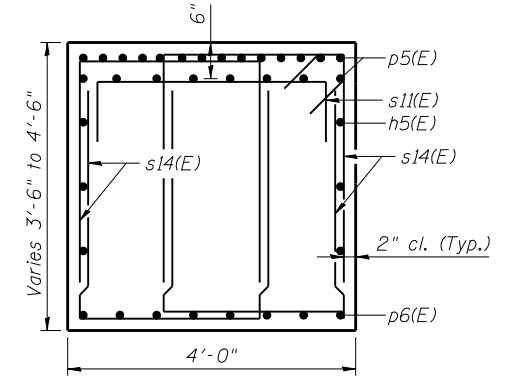

**SEC. B-B**

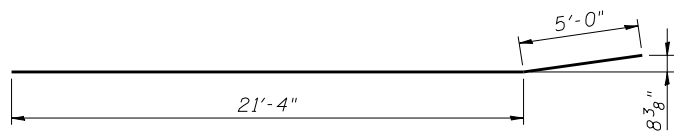

**BAR p6(E)**

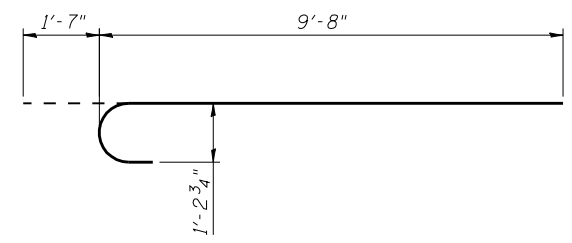

**BAR n(E)**

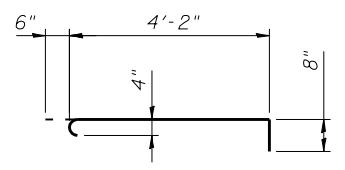

**BAR s10(E)**

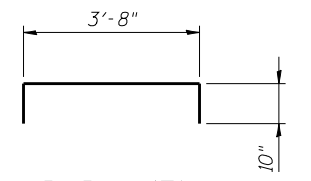

**BAR s11(E)**

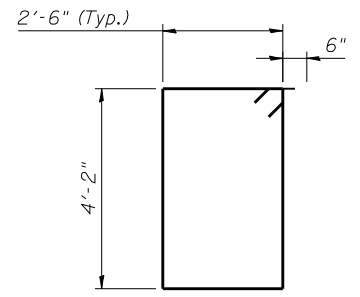

**BAR s12(E)**

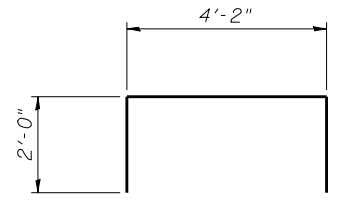

**BAR s13(E)**

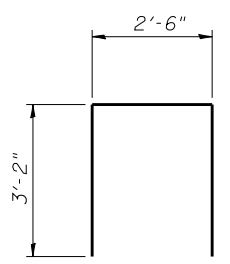

**BAR s14(E)**

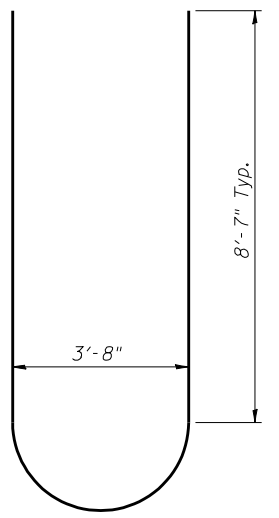

**BAR u3(E)**

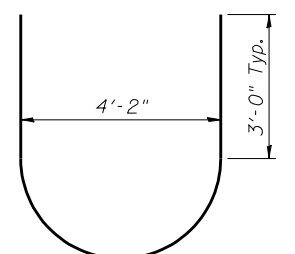

**BAR u4(E)**

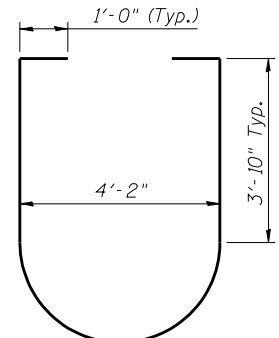

**BAR u5(E)**

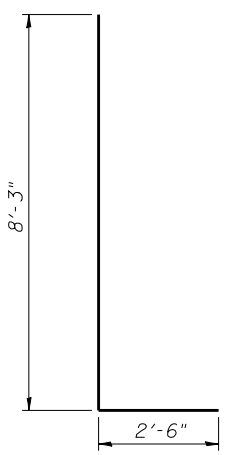

**BAR v7(E)**

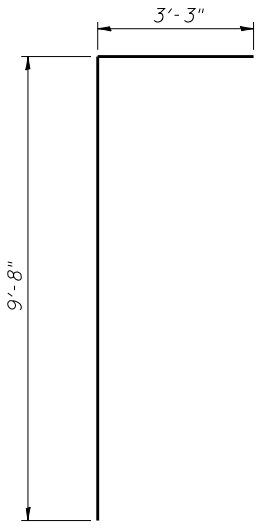

**BAR v8(E)**

**BILL OF MATERIAL**

Bar	No.	Size	Length	Shape
h5(E)	12	#5	24'-7"	—
h6(E)	48	#6	18'-8"	—
h7(E)	8	#6	27'-6"	—
n(E)	92	#11	11'-3"	U
p5(E)	44	#9	27'-3"	—
p6(E)	16	#9	26'-4"	—
s10(E)	200	#4	5'-4"	U
s11(E)	51	#5	5'-4"	U
s12(E)	248	#6	14'-4"	U
s13(E)	58	#11	8'-2"	U
s14(E)	192	#5	8'-10"	U
** sp(E)	4	#5	14'-3 1/2"	W
t1(E)	43	#8	18'-8"	—
t2(E)	85	#10	18'-8"	—
u3(E)	8	#9	22'-11"	U
u4(E)	8	#6	12'-6"	U
u5(E)	24	#6	16'-2"	U
v7(E)	164	#11	10'-9"	U
v8(E)	92	#11	12'-11"	U
v9(E)	164	#11	10'-11"	U
w1(E)	88	#8	24'-3"	—
Structure Excavation		Cu. Yd.	177	
Concrete Structures		Cu. Yd.	269.3	
Reinforcement Bars, Epoxy Coated		Pound	65,430	
Furnishing Steel Piles, HP 12x53		Foot	2,223	
Driving Piles		Foot	2,223	
Test Pile Steel, HP 12x53		Each	1	
Pile Shoes		Each	40	

\*\* Length is height of spiral.  
Bars indicated thus 1 x 5-#5 etc. indicates 1 line of bars with 5 lengths per line.

FILE NAME = 0820117-0118-76884-046-PierDetailsEB.dgn



USER NAME = brazzara	DESIGNED - SAB	REVISED -
	CHECKED - MJK	REVISED -
PLOT SCALE = 8x0.0000 '1' / IN.	DRAWN - RAB	REVISED -
PLOT DATE = 10/19/2011	CHECKED - SAB	REVISED -

**STATE OF ILLINOIS  
DEPARTMENT OF TRANSPORTATION**

**PIER DETAILS EASTBOUND  
STRUCTURE NO. 082-0117 (E.B.) & 082-0118 (W.B.)**

SHEET NO. S-46 OF S-62 SHEETS

F.A.P. RTE.	SECTION	COUNTY	TOTAL SHEETS	SHEET NO.
103	27-1-VHB-1	ST. CLAIR	277	161
CONTRACT NO. 76884				
ILLINOIS FED. AID PROJECT				