

2-3/4" ϕ H.S. Bolts w/ lock washers (Typ. ea. side) (Coat bolts with anti-seize compound)
Tapped holes in middle $\frac{1}{8}$ " ϕ holes in bearing $\frac{1}{8}$ " ϕ Bearing

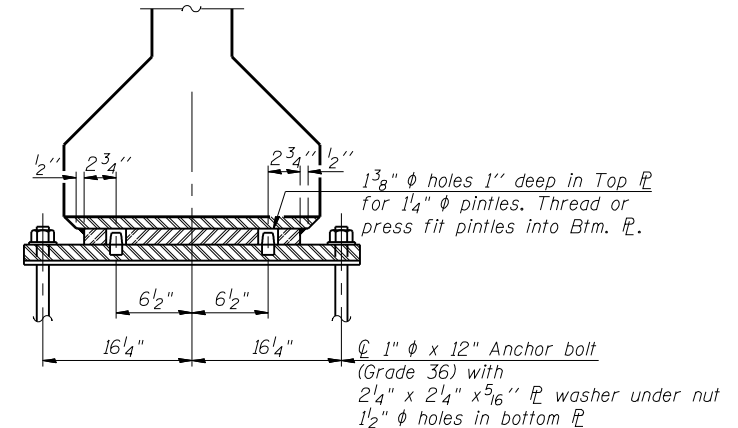

TYPE I ELASTOMERIC EXP. BRG.

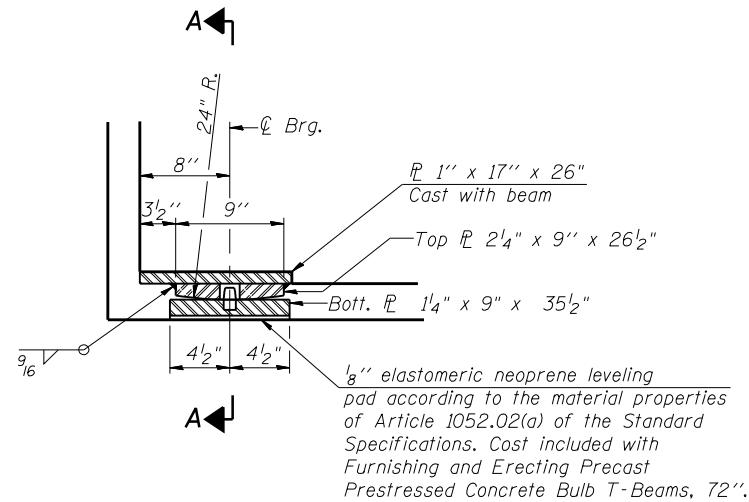
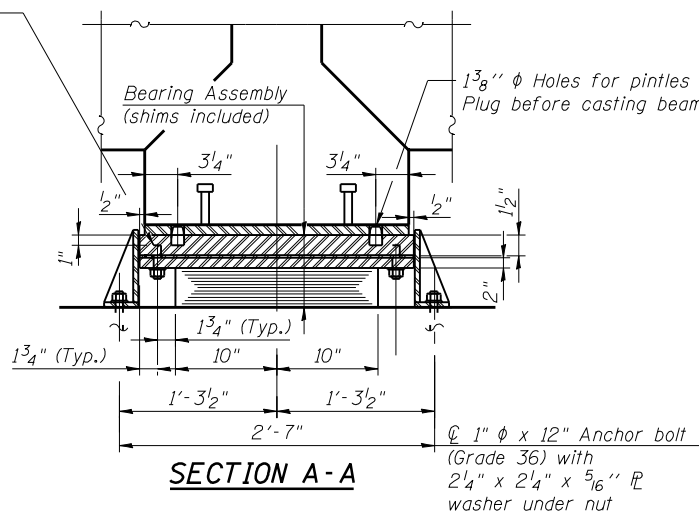
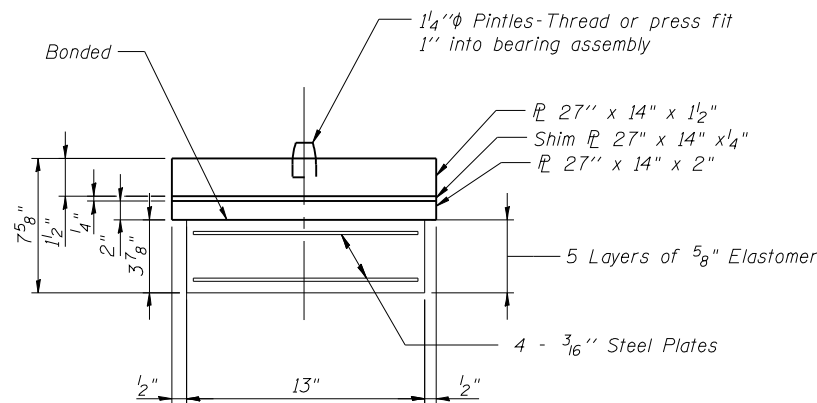

BEARING ASSEMBLY

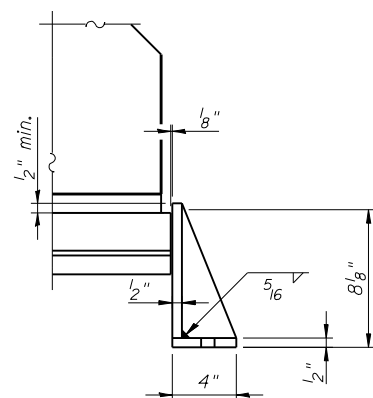

SIDE RETAINER
Equivalent rolled angle with stiffeners will be allowed in lieu of welded plates.

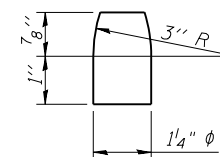
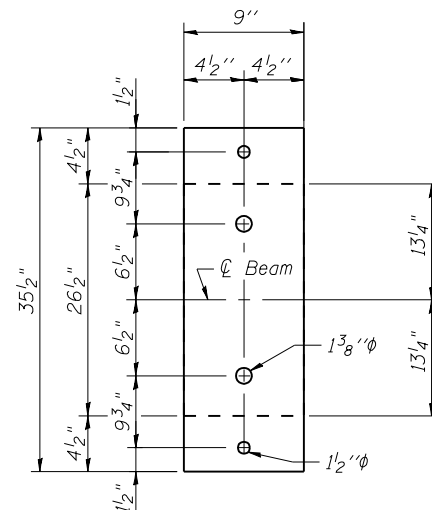

Notes:
Anchor bolts shall be ASTM F1554 all-thread (or an Engineer-approved alternate material) of the grade(s) and diameter(s) specified. ASTM A307 Grade C anchor bolts may be used in lieu of ASTM F1554 Grade 36 (Fy=36ksi). The corresponding specified grade of AASHTO M314 anchor bolts may be used in lieu of ASTM F1554.
Anchor bolts for side retainers may be cast in place or installed in holes drilled after members are in place.
Anchor bolts at fixed bearings may be either cast in place or installed in holes drilled after the supported member is in place and prior to pouring the deck.
Drilled and set anchor bolts shall be installed according to Article 521.06 of the Standard Specifications.
Side retainers and other steel members required for the bearing assembly shall be included in the cost of Elastomeric Bearing Assembly, Type I.
See sheet S-31 of S-46 for additional details of plate cast with beam.
All (embedded and separate) bearing plates, side retainers, anchor bolts, nuts, washers and pintles shall be galvanized according to AASHTO M111 or M232 as applicable.
H.S. bolts in bearing assembly shall be galvanized according to AASHTO M298 Class 50.

BILL OF MATERIAL

Item	Unit	Total
Elastomeric Bearing Assembly, Type I	Each	16
Anchor Bolts 1"	Each	32

FILE NAME = 0820119-0120-76884-032-Bearing.dgn



USER NAME = brazzano	DESIGNED - MJK	REVISED - -
PLOT SCALE = 0.2 '1" / IN.	CHECKED - JAN	REVISED - -
PLOT DATE = 10/19/2011	DRAWN - RAB	REVISED - -
	CHECKED - JAN	REVISED - -

STATE OF ILLINOIS
DEPARTMENT OF TRANSPORTATION

BEARING DETAILS
STRUCTURE NO. 082-0119 (EB) & 082-0120 (WB)

SHEET NO. S-32 OF S-51 SHEETS

F.A.P. RTE.	SECTION	COUNTY	TOTAL SHEETS	SHEET NO.
103	27-1-VHB-1	ST. CLAIR	277	209
				CONTRACT NO. 76884
ILLINOIS FED. AID PROJECT				