

SIDEROAD DETAIL

*EOP ELEVATION CHANGE	**TOTAL TRANSITION LENGTH
2-1/2"	12.5'

THIS DETAIL EXCLUDES SIDEROADS WHERE LOOP DETECTORS ARE BEING REPLACED.

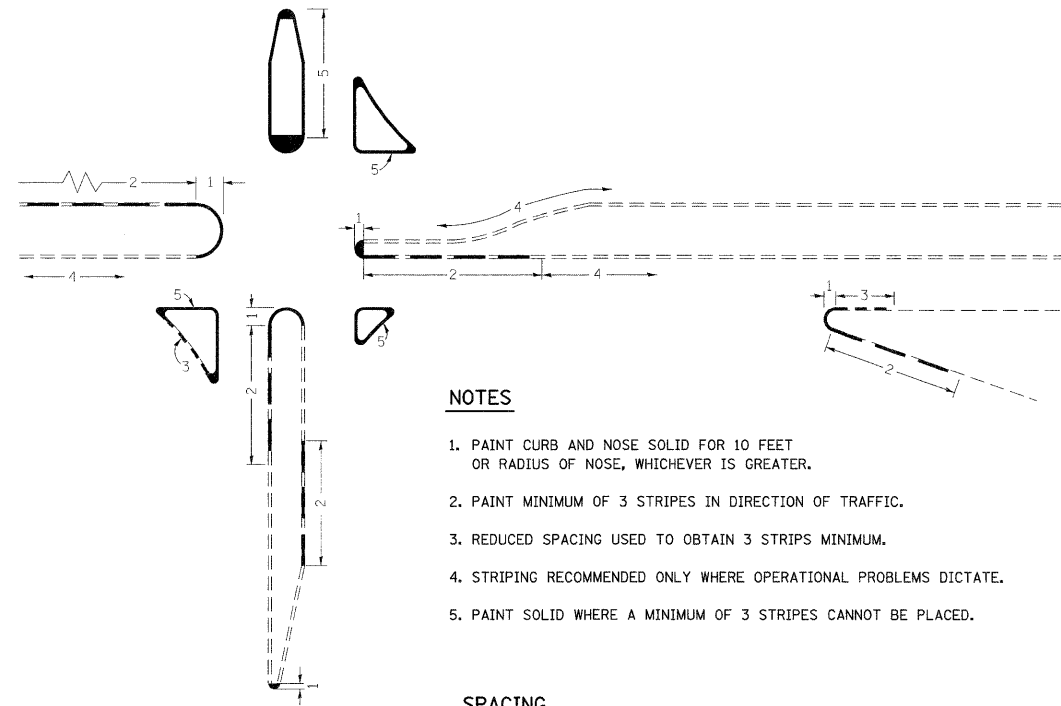

NOTES

1. PAINT CURB AND NOSE SOLID FOR 10 FEET OR RADIUS OF NOSE, WHICHEVER IS GREATER.
2. PAINT MINIMUM OF 3 STRIPES IN DIRECTION OF TRAFFIC.
3. REDUCED SPACING USED TO OBTAIN 3 STRIPES MINIMUM.
4. STRIPING RECOMMENDED ONLY WHERE OPERATIONAL PROBLEMS DICTATE.
5. PAINT SOLID WHERE A MINIMUM OF 3 STRIPES CANNOT BE PLACED.

SPACING

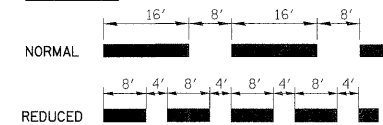

CURB MARKING

SHALL BE PAID FOR AS PAINT PAVEMENT MARKING 4"

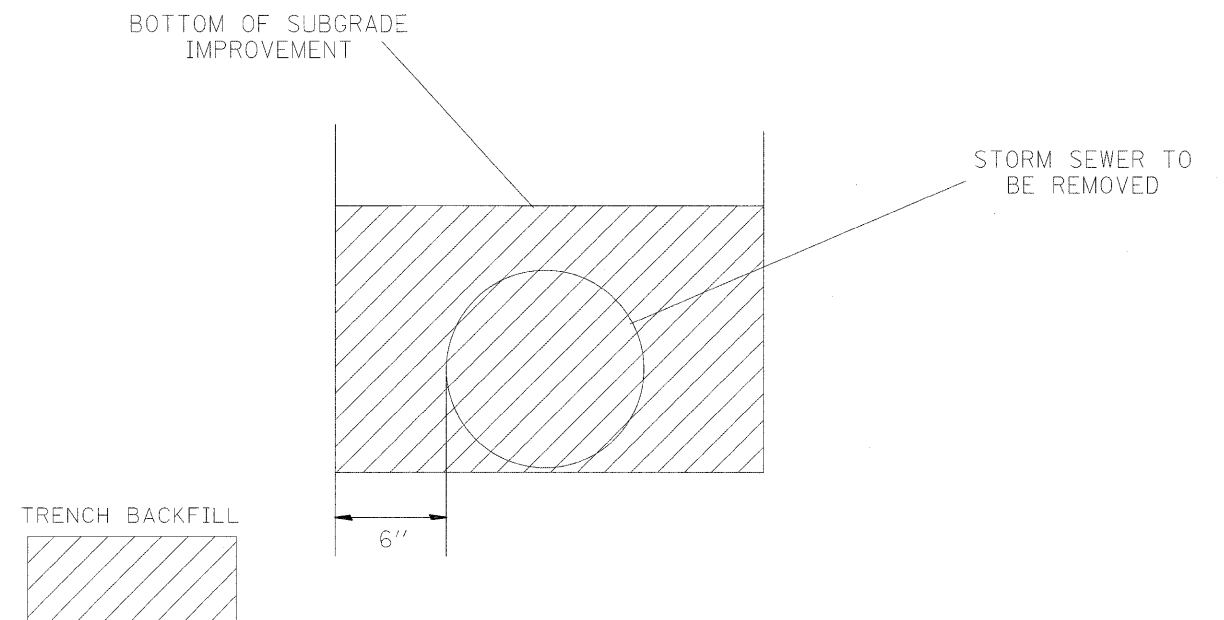

TRENCH BACKFILL DETAIL

REVISOR'S MARK: **REVISOR'S MARK** REVISED SHEET 4/13/11

FILE NAME =	USER NAME = karlasal	DESIGNED -	REVISOR'S MARK	STATE OF ILLINOIS DEPARTMENT OF TRANSPORTATION	DETAILS	F.A.P. RTE.	SECTION	COUNTY	TOTAL SHEETS	SHEET NO.	
os:\pw\work\pwi\dot\karlasal\1\08169744\0875802-sht-plan.dgn	PLCT SCALE = 50.0000' / IN.	DRAWN -	REVISOR'S MARK			785	(132-2,3,4, 133-1RS)	MADISON	122	60	
	PLCT DATE = 3/18/2011	CHECKED -	REVISOR'S MARK			CONTRACT NO. 76B80					
		DATE -	REVISOR'S MARK			FED. ROAD DIST. NO. _ [ILLINOIS] FED. AID PROJECT					