

**TYPICAL SECTION**  
 STA. 21+73.19 TO STA. 24+00.00  
 STA. 36+38.17 TO STA. 37+21.34  
 (MULTI-USE PATH)

**LIGHTFOOT RD.**  
 OMISSION  
 STA. 35+89.37 TO STA. 36+38.17

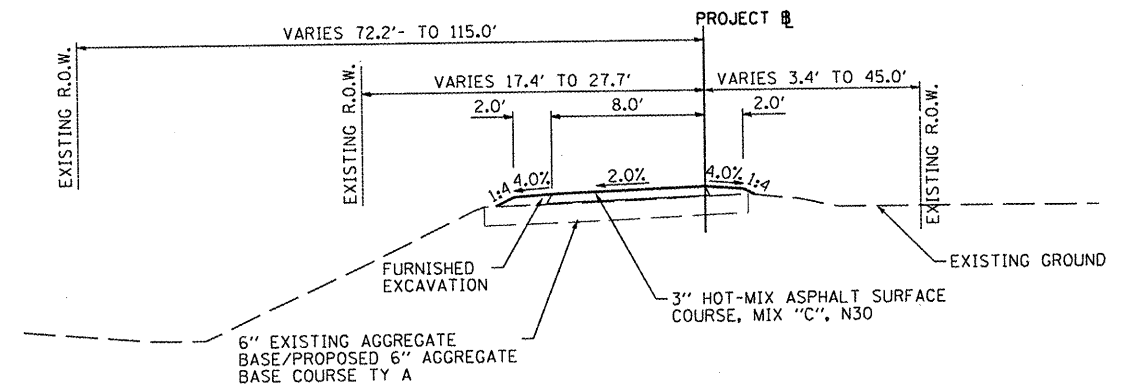

**TYPICAL SECTION**  
 STA. 24+00.00 TO STA. 35+89.37  
 (MULTI-USE PATH)

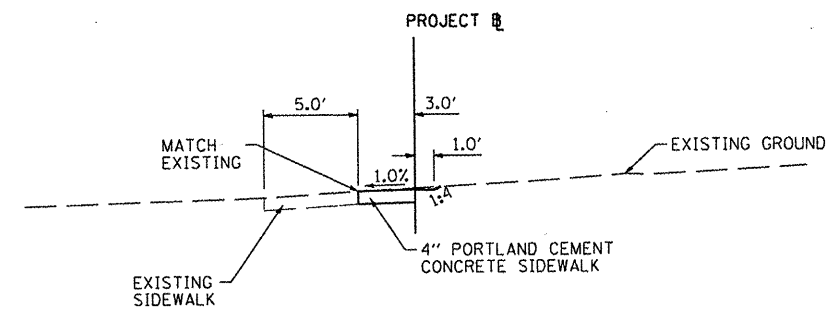

**TYPICAL SECTION**  
 STA. 37+15.80 TO STA. 43+51.81  
 (AT SCHOOL)

FILE NAME = s:\247\24710001 Farmington SRTS\CADD\CAD	USER NAME = wllewis	DESIGNED - JDS	REVISED -	<b>STATE OF ILLINOIS</b> <b>DEPARTMENT OF TRANSPORTATION</b>	<b>CITY OF FARMINGTON SRTS</b> <b>TYPICAL SECTION</b>			SECTION	COUNTY	TOTAL SHEETS	SHEET NO.
	D Sheets\0489569-shr-typical.dgn	DRAWN - WLL	REVISED -		08-00032-00-SW	FULTON	16	3			
	PLOT SCALE = 40.0000' / IN.	CHECKED - GBM	REVISED -		CONTRACT NO. 89569						
	PLOT DATE = 10/26/2011	DATE -	REVISED -		ILLINOIS FED. AID PROJECT						
				SCALE:	SHEET NO.	OF	SHEETS	STA.	TO STA.		