

STATE OF ILLINOIS  
DEPARTMENT OF TRANSPORTATION  
DIVISION OF HIGHWAYS

**PROPOSED  
HIGHWAY PLANS**  
VARIOUS ROUTES  
[FAI72, FAP310, FAP757 (I-72, US67, IL 100/106)]  
SECTION D6 BRIDGE CLEANING 2017-1

**BRIDGE WASHING  
PIKE, CASS, & SCOTT COUNTIES**

C-96-007-17

F.A. RTE.	SECTION	COUNTY	TOTAL SHEETS	SHEET NO.
VAR. D6 BRIDGE CLEANING 2017-1			7	1
PIKE, CASS, & SCOTT ILLINOIS		CONTRACT NO. 72J48		

FOR INDEX OF SHEETS, SEE SHEET NO. 2

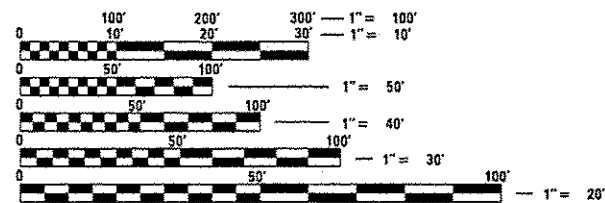
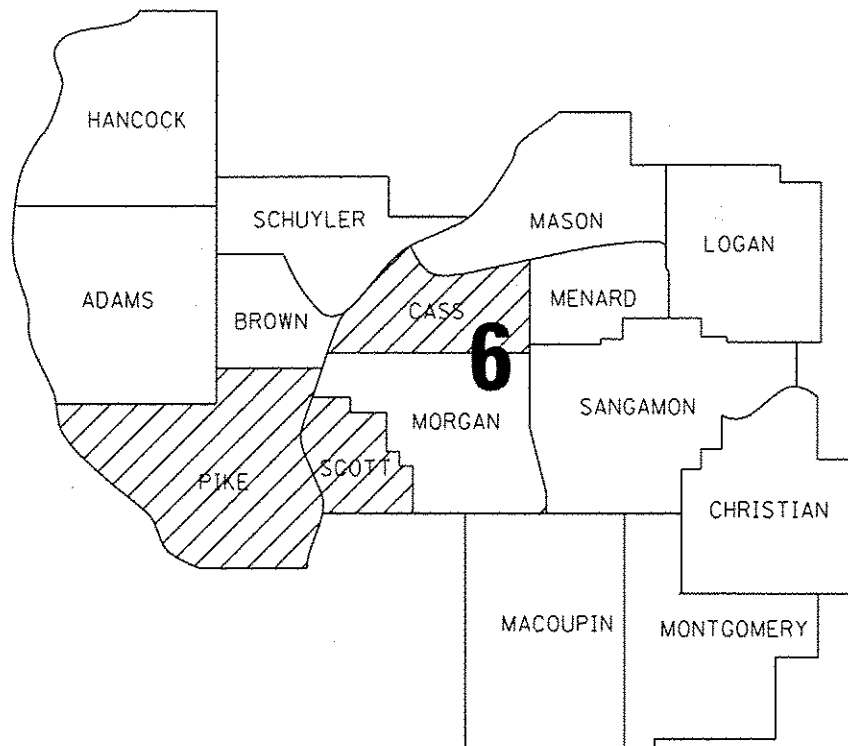
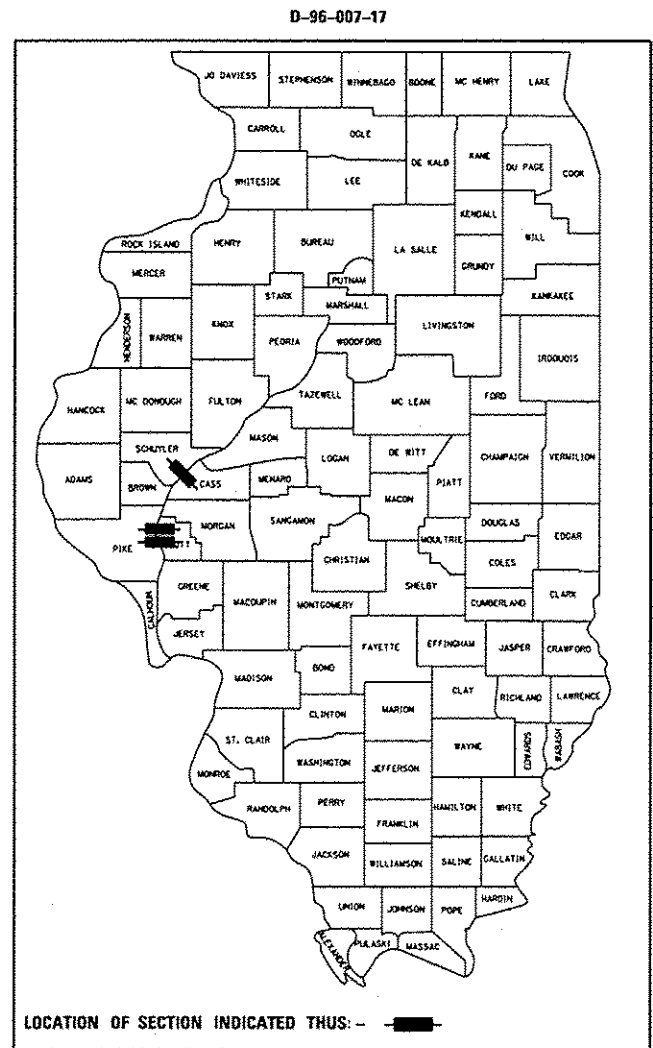

FULL SIZE PLANS HAVE BEEN PREPARED USING STANDARD ENGINEERING SCALES. REDUCED SIZED PLANS WILL NOT CONFORM TO STANDARD SCALES. IN MAKING MEASUREMENTS ON REDUCED PLANS, THE ABOVE SCALES MAY BE USED.

J.U.L.I.E.  
JOINT UTILITY LOCATION INFORMATION FOR EXCAVATION  
1-800-892-0123  
OR 811

BRIDGE MAINTENANCE ENGINEER: BRANDON DUDLEY, 217-785-9290

BRIDGE INSPECTION ENGINEER: DAVE COPENBARGER, 217-785-5306

CONTRACT NO. 72J48

GROSS LENGTH = x.xx FT. = x.xxx MILE  
NET LENGTH = 6803 FT. = 1.29 MILE

STATE OF ILLINOIS  
DEPARTMENT OF TRANSPORTATION  
DIVISION OF HIGHWAYS

SUBMITTED *25 October 2016*

*[Signature]* REGION FOUR ENGINEER

*Dec 9 2016*  
*Maureen M. Addis, P.E.*  
ENGINEER OF DESIGN AND ENVIRONMENT

*Dec 9 2016*  
*Over Osman, P.E.*  
DIRECTOR OF HIGHWAYS/CHIEF ENGINEER

**PRINTED BY THE AUTHORITY  
OF THE STATE OF ILLINOIS**

INDEX OF SHEETS

- 1 COVER SHEET
- 2 INDEX, STANDARDS, GENERAL NOTES, & SIGNATURES
- 3 SUMMARY OF QUANTITIES
- 4-7 LOCATION MAPS & BRIDGE PLANS

HIGHWAY  
STANDARDS

- 000001-06
- 001006
- 701001-02
- 701006-05
- 701101-05
- 701106-02
- 701201-04
- 701400-09
- 701406-11
- 701901-06

GENERAL NOTES:

BRIDGE #1 - SN 009-0001: US 67 OVER THE ILLINOIS RIVER AT THE WEST EDGE OF BEARDSTOWN IN CASS COUNTY.

BRIDGE #2 - SN 086-0001: IL 100/106 OVER THE ILLINOIS RIVER AT THE EAST EDGE OF FLORENCE IN SCOTT COUNTY.

BRIDGE #3 - SN 075-0122: I-72 EB OVER THE ILLINOIS RIVER SOUTH OF VALLEY CITY IN PIKE COUNTY.

BRIDGE #4 - SN 075-0123: I-72 WB OVER THE ILLINOIS RIVER SOUTH OF VALLEY CITY IN PIKE COUNTY.

ALL BRIDGE WASHING SHALL BE PERFORMED IN ACCORDANCE WITH ARTICLE 592 OF THE STANDARD SPECIFICATIONS AND AS OUTLINED BELOW:

TRUSS SPANS - THE AREAS OF TRUSS SPANS TO BE WASHED SHALL INCLUDE THE FOLLOWING:

- ALL STRUCTURAL STEEL INCLUDING LOWER CHORD TO A POINT OF 10' ABOVE THE BRIDGE DECK
- THE ENTIRE DECK SURFACE, CURB, JOINTS, DRAINS, AND RAILINGS
- ALL FLOOR BEAMS, DIAGONAL BRACING, STRINGERS, AND OTHER STRUCTURAL STEEL FROM THE LOWER CHORD INWARD TO AND INCLUDING THE OUTSIDE AND BOTTOM OF EXTERIOR STRINGERS
- ALL ABUTMENT AND PIER CAPS
- ALL STRUCTURAL STEEL LOCATED BELOW THE DECK WITHIN 10' LONGITUDINALLY ON EITHER SIDE OF ALL EXPANSION JOINTS OR DEFLECTION JOINTS

MULTI BEAM OR APPROACH SPANS - THE AREAS TO BE WASHED ON MULTI BEAM SPANS OR APPROACH SPANS SHALL INCLUDE THE FOLLOWING:

- ALL DECK JOINTS AND DECK DRAINS
- THE ENTIRE DECK SURFACE, CURB, AND RAILINGS
- THE OUTSIDE AND BOTTOMS OF FASCIA BEAMS
- ALL ABUTMENT AND PIER CAPS
- ALL STRUCTURAL STEEL LOCATED BELOW THE DECK WITHIN 10' LONGITUDINALLY ON EITHER SIDE OF ALL EXPANSION JOINTS OR DEFLECTION JOINTS

POST-TENSIONED CONCRETE SEGMENTAL SPANS - THE AREAS TO BE WASHED ON POST-TENSIONED CONCRETE SEGMENTAL SPANS SHALL INCLUDE THE FOLLOWING:

- ALL DECK JOINTS AND DECK DRAINS
- THE ENTIRE DECK SURFACE, CURB, AND RAILINGS

<b>STATE OF ILLINOIS DEPARTMENT OF TRANSPORTATION DIVISION OF HIGHWAYS DISTRICT 6</b>	
EXAMINED	October 11 <sup>th</sup> 20 16 <i>John C. Wagoner</i> ENGINEER OF OPERATIONS
EXAMINED	October 6 20 16 <i>Ross Buchanan</i> ENGINEER OF PROJECT IMPLEMENTATION
EXAMINED	October 11 20 16 <i>Jeffrey P. May</i> ENGINEER OF PROGRAM DEVELOPMENT

FILE NAME *	USER NAME * dudleybn	DESIGNED -	REVISED -	<b>STATE OF ILLINOIS DEPARTMENT OF TRANSPORTATION</b>	<b>INDEX, STANDARDS, GENERAL NOTES, &amp; SIGNATURES</b>	F.A. RTE.	SECTION	COUNTY	TOTAL SHEETS	SHEET NO.
D:\OPERATIONS\Bridges\Bridgplans.CAD\72J48 - IL River bridge washing 2017\plansheet.d	J48 - IL River bridge washing 2017\plansheet.d	DRAWN -	REVISED -			VAR.	D6 BRIDGE CLEANING 2017-	*	7	2
Default	PLOT SCALE * 1/8" = 1' in.	CHECKED -	REVISED -		SCALE:		* PIKE, CASS, & SCOTT			CONTRACT NO. 72J48
	PLOT DATE * 10/20/2016	DATE -	REVISED -							ILLINOIS FED. AID PROJECT

## SUMMARY OF QUANTITIES

ITEM NO.	DESCRIPTION	UNIT	TOTAL QTY	100% STATE	100% STATE	100% STATE
				0014	0014	0014
				CASS	SCOTT	PIKE
59200101	BRIDGE WASHING NO. 1	EACH	1	1	0	0
59200102	BRIDGE WASHING NO. 2	EACH	1	0	1	0
59200103	BRIDGE WASHING NO. 3	EACH	1	0	0	1
59200104	BRIDGE WASHING NO. 4	EACH	1	0	0	1
67100100	MOBILIZATION	L SUM	1	0.25	0.25	0.5
70100450	TRAFFIC CONTROL AND PROTECTION STANDARD 701201	L SUM	1	0.5	0.5	0
70100700	TRAFFIC CONTROL AND PROTECTION STANDARD 701406	L SUM	1	0	0	1
X7010410	SPEED DISPLAY TRAILER	CAL MO	1	0	0	1

8

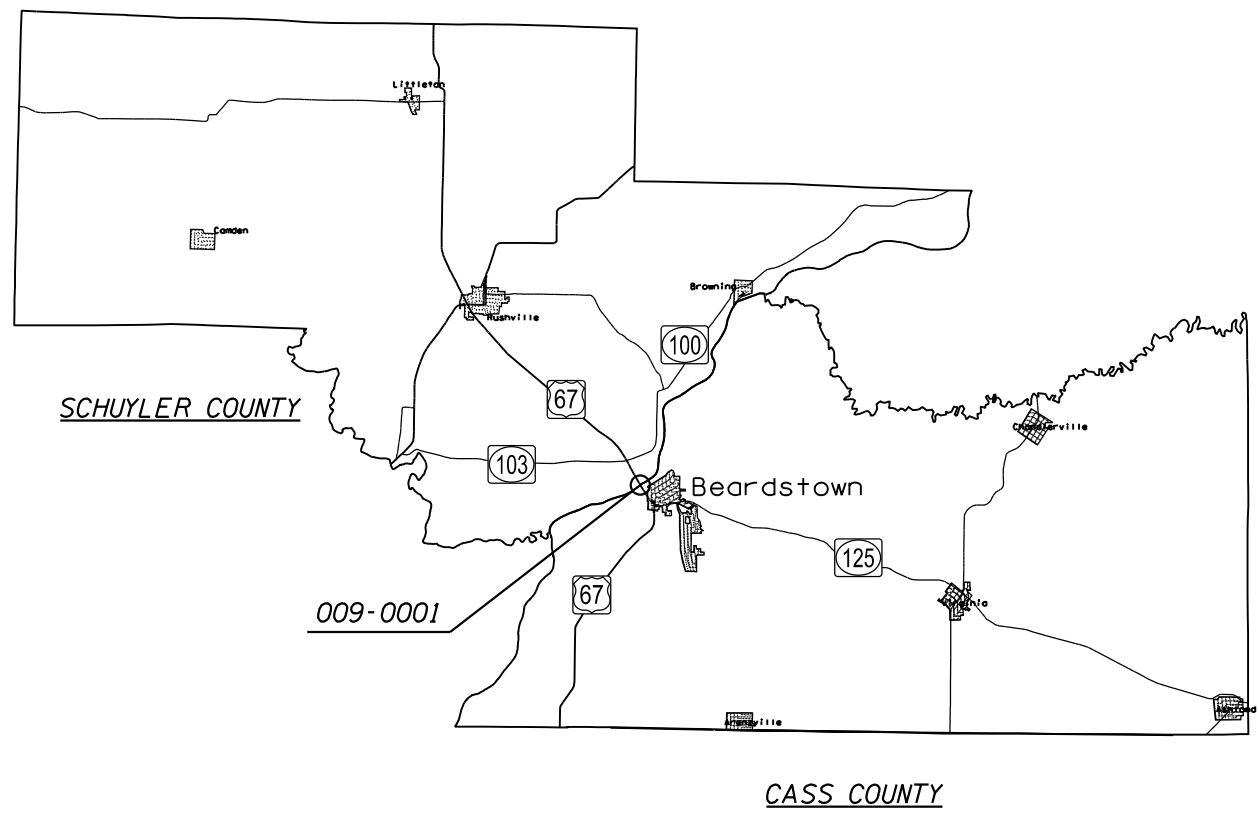
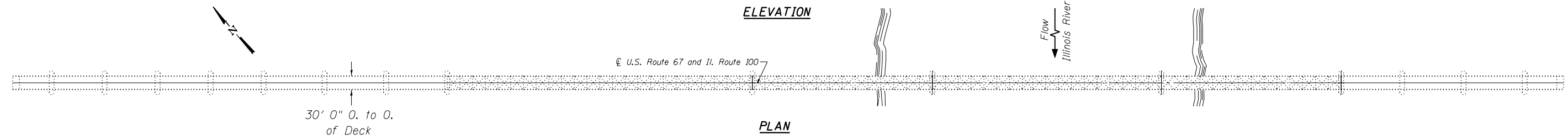
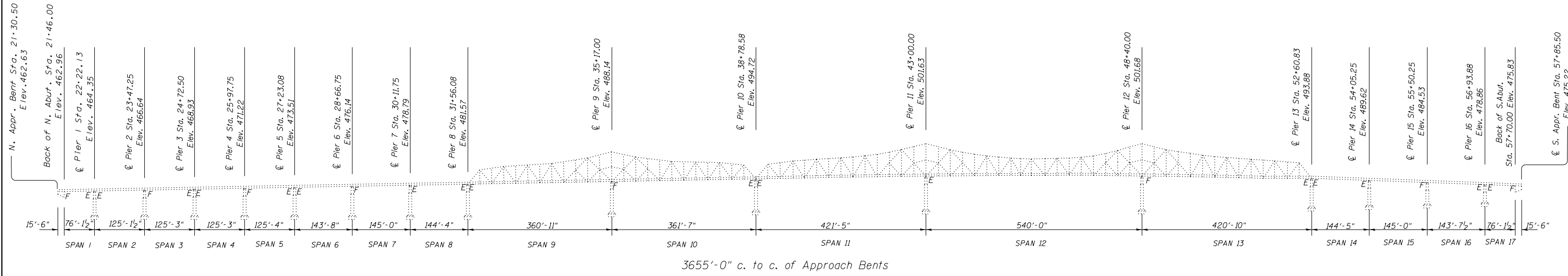

FILE NAME =	USER NAME = dudleybm	DESIGNED -	REVISED -	<b>STATE OF ILLINOIS DEPARTMENT OF TRANSPORTATION</b>	<b>SN 009-0001 LOCATION MAP &amp; GENERAL PLAN &amp; ELEVATION</b>				F.A. -	SECTION	COUNTY	TOTAL	SHEET
Default	0:\OPERATIONS\Bridges\Bridgplans\CAD\7248 - IL River bridge washing 2017\plansheet	DRAWN -	REVISED -						VAR.	D6 BRIDGE CLEANING 2017-	*	7	4
	PLOT SCALE = 10000.0000' / in.	CHECKED -	REVISED -		* PIKE, CASS, & SCOTT				CONTRACT NO. 72J48				
	PLOT DATE = 10/20/2016	DATE -	REVISED -		SCALE:	SHEET	OF	SHEETS	STA.	TO	STA.	ILLINOIS FED. AID PROJECT	

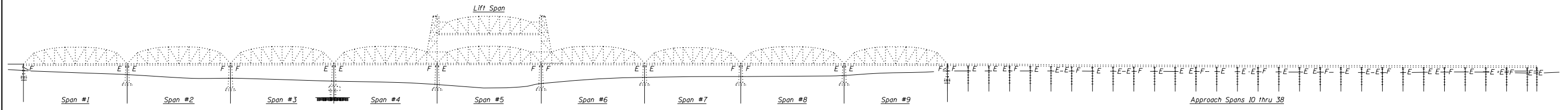

**ELEVATION**

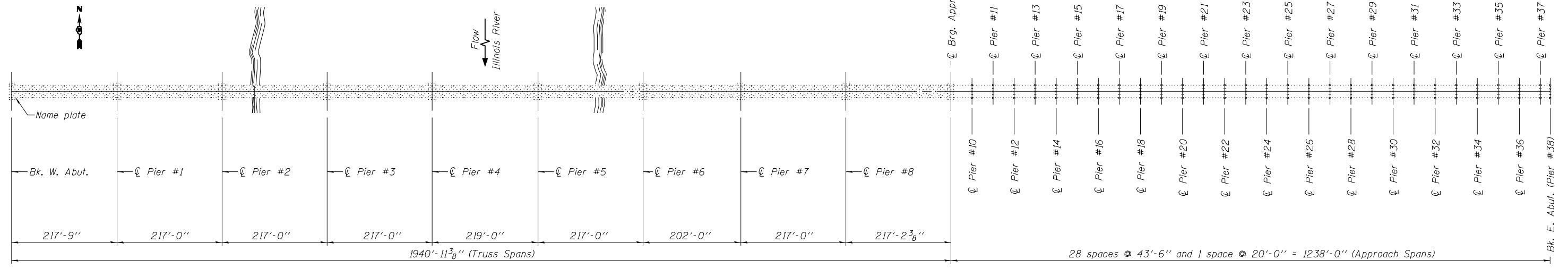

**PLAN**

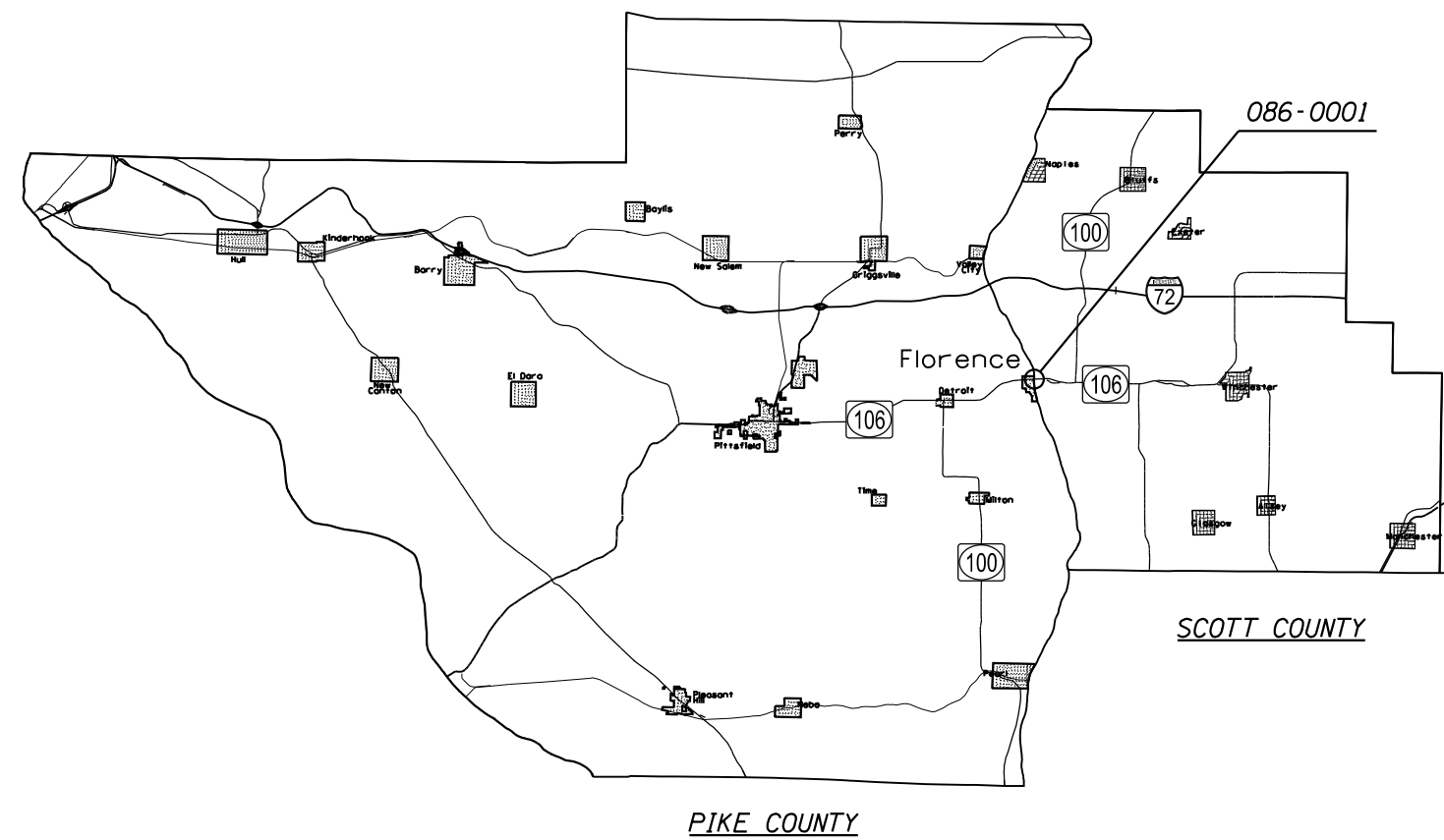

**STATE OF ILLINOIS  
DEPARTMENT OF TRANSPORTATION**

**SN 086-0001 LOCATION MAP &  
GENERAL PLAN & ELEVATION**

SCALE: SHEET OF SHEETS STA. TO STA.

F.A. RTE.	SECTION	COUNTY	TOTAL SHEETS	SHEET NO.
VAR. D6 BRIDGE CLEANING 2017-1			7	5
• PIKE, CASS, & SCOTT			CONTRACT NO. 72J48	
ILLINOIS FED. AID PROJECT				

FILE NAME =	USER NAME = dudleybm	DESIGNED -	REVISED -
D:\OPERATIONS\Bridges\Bridgplans\CAD\72J48 - IL River bridge cleaning 2017\plansheets		DRAWN -	REVISED -
Default	PLOT SCALE = 10000.0000' / in.	CHECKED -	REVISED -
	PLOT DATE = 10/20/2016	DATE -	REVISED -

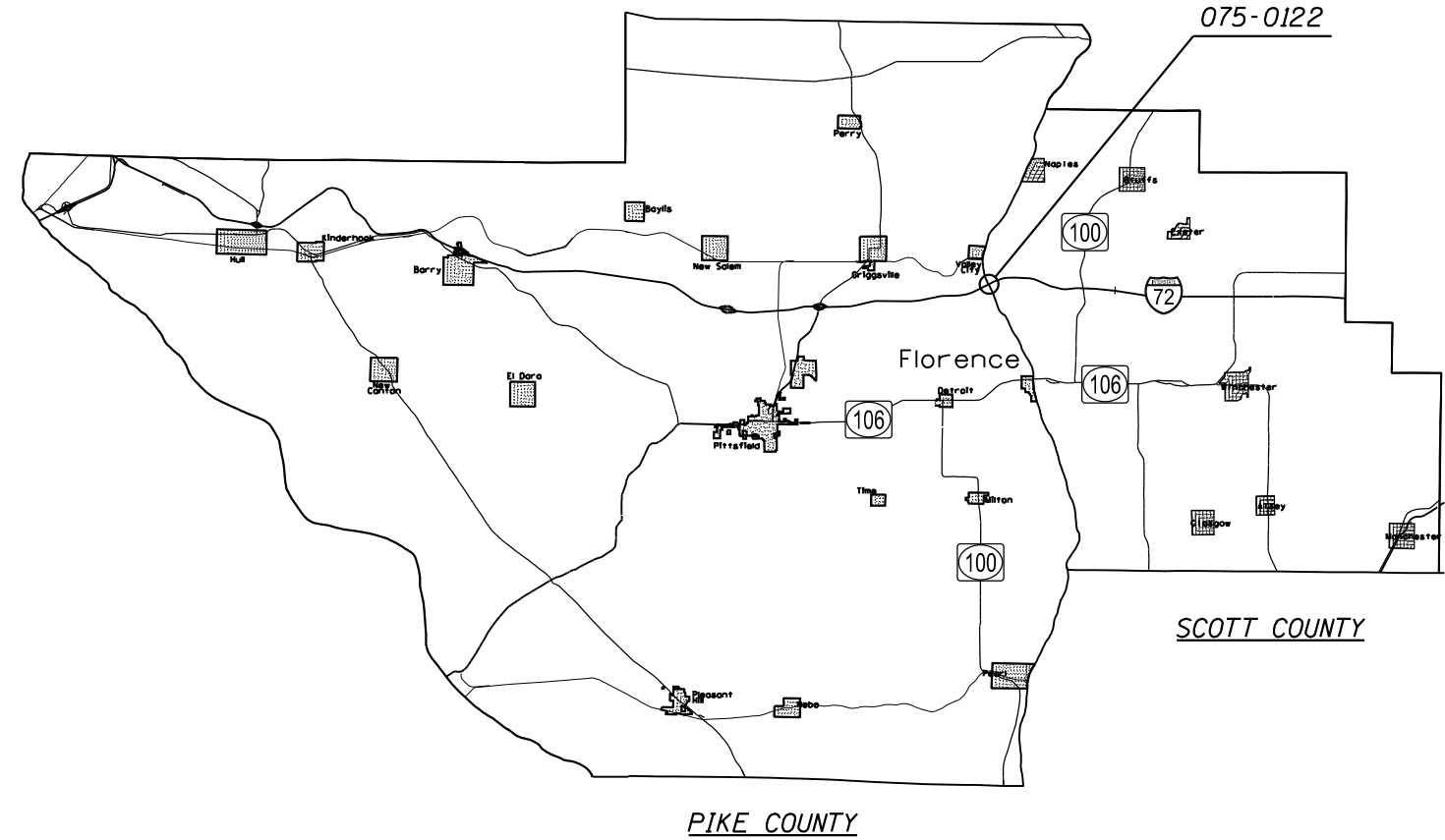
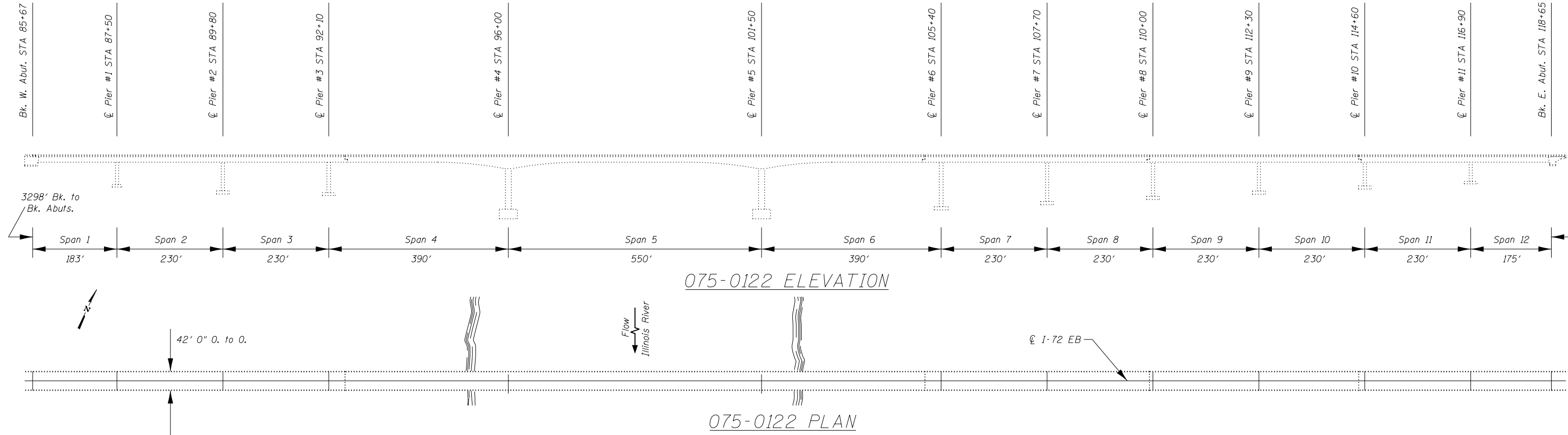

FILE NAME =	USER NAME = dudleybm	DESIGNED -	REVISED -
D:\OPERATIONS\Bridges\Bridgplans\CAD\72	J48 - IL River bridge washing 2017\plansheets	DRAWN -	REVISED -
Default	PLOT SCALE = 10000.0000' / in.	CHECKED -	REVISED -
	PLOT DATE = 10/20/2016	DATE -	REVISED -

**STATE OF ILLINOIS  
DEPARTMENT OF TRANSPORTATION**

**SN 075-0122 LOCATION MAP &  
GENERAL PLAN & ELEVATION**

SCALE:      SHEET      OF      SHEETS      STA.      TO      STA.

F.A. RTE.	SECTION	COUNTY	TOTAL SHEETS	SHEET NO.
VAR. D6 BRIDGE CLEANING 2017-		*	7	6
* PIKE, CASS, & SCOTT			CONTRACT NO. 72J48	
ILLINOIS FED. AID PROJECT				

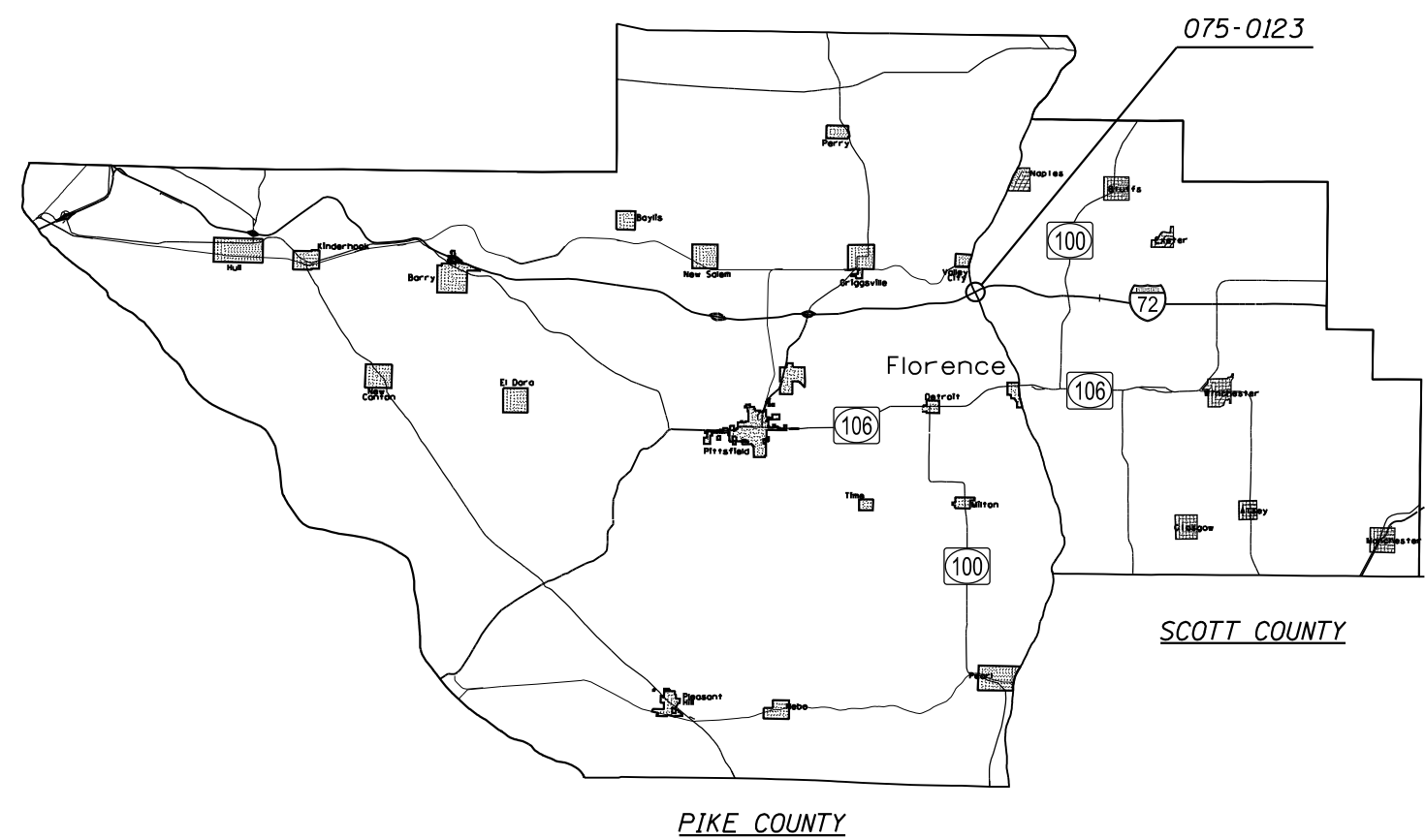
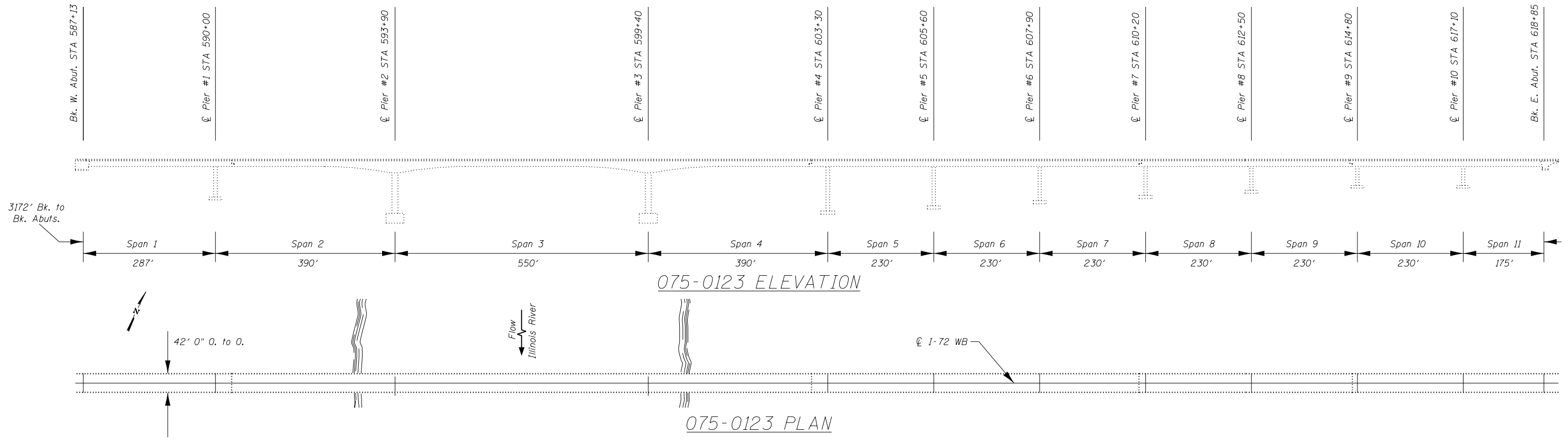

FILE NAME =	USER NAME = dudleybm	DESIGNED -	REVISED -
D:\OPERATIONS\Bridges\Bridgplans\CAD\72	J48 - IL River bridge washing 2017\plansheet	DRAWN -	REVISED -
Default	PLOT SCALE = 10000.0000' / in.	CHECKED -	REVISED -
	PLOT DATE = 10/20/2016	DATE -	REVISED -

**STATE OF ILLINOIS  
DEPARTMENT OF TRANSPORTATION**

**SN 075-0123 LOCATION MAP &  
GENERAL PLAN & ELEVATION**

SCALE:      SHEET      OF      SHEETS      STA.      TO      STA.

F.A. RTE.	SECTION	COUNTY	TOTAL SHEETS	SHEET NO.
VAR. D6 BRIDGE CLEANING 2017-1		*	7	7
* PIKE, CASS, & SCOTT			CONTRACT NO. 72J48	
ILLINOIS FED. AID PROJECT				