

- LEGEND**
- ① EXIST. P.C.C PAVEMENT (10" & VARIES)
 - ② EXIST. BITUMINOUS SURFACE, ± 4"
 - ②A EXIST. BITUMINOUS SURFACE, ± 6"
 - ③ EXIST. AGGREGATE SHOULDER
 - ④ EXIST. BITUMINOUS WIDENING
 - ⑤ EXIST. CONCRETE CURB AND GUTTER, TYPE B-6.24
 - ⑥ PROP. BITUMINOUS SURFACE REMOVAL, 2/4"
 - ⑦ PROP. . BIT. CONC. SURFACE COURSE, SUPERPAVE, MIX "D", N70, 1/2"
 - ⑧ PROP. POLY. LEVELING BINDER (MM), SUPERPAVE, IL-4.75, N50, 3/4"
 - ⑨ PROP. AGGREGATE SHOULDERS, TYPE B
 - ⑩ PROP. HOT IN-PLACE RECYCLING, 3/4"
 - ⑪ PROP. BIT. SURFACE REMOVAL, 1/2"

MIXTURE REQUIREMENTS				
MIXTURE USES	AC / PG	RAP % (MAX)	DESIGN AIR VOIDS	DESIGNER CALCULATION BASED ON
BIT. CONC. SURFACE COURSE, SUPERPAVE, MIX "D", N70	PG 64-22	10	4% AT 70 GYR.	112 LBS/SY/IN
CLASS D PATCHES MIXES (BINDER IL-19, N70)	PG 64-22	15%	4% AT 70 GYR.	
POLY. LEVELING BINDER (MM) SUPERPAVE, IL-4.75, N50	SBS/SBR PG 76-28	0	2.5% AT 50 GYR.	110 LBS/SY/IN
BIT. REPLACEMENT OVER PATCHES BINDER IL-19, N70	PG 64-22	15%	4% AT 70 GYR.	

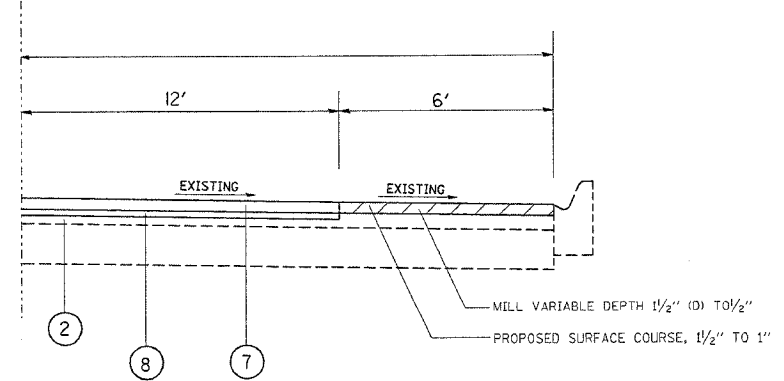

EXIST. AND PROP. PARKING LANE TYPICAL SECTION

REVISIONS	
NAME	DATE

ILLINOIS DEPARTMENT OF TRANSPORTATION

ILLINOIS ST.

STATE ST. TO MAIN ST.

EXISTING & PROPOSED

TYPICAL SECTIONS

SCALE: VERT. NONE
HORIZ. DATE DATE

DRAWN BY
CHECKED BY

10/20/2004
 c:\p\proj\sect\sect\48700\del\48700a.m32
 VI=TYPI