

F.A.U. RTE.	SECTION	COUNTY	TOTAL SHEETS	SHEET NO.
3732	00-00125-00-BR	COOK	58	28
STA. 102+57.23	TO STA. 103+82.77			
FED. ROAD DIST. NO.	ILLINOIS	PROJECT	BHM-7003(B02)	
Sheet S-11 of S-28			CONTRACT 83584	

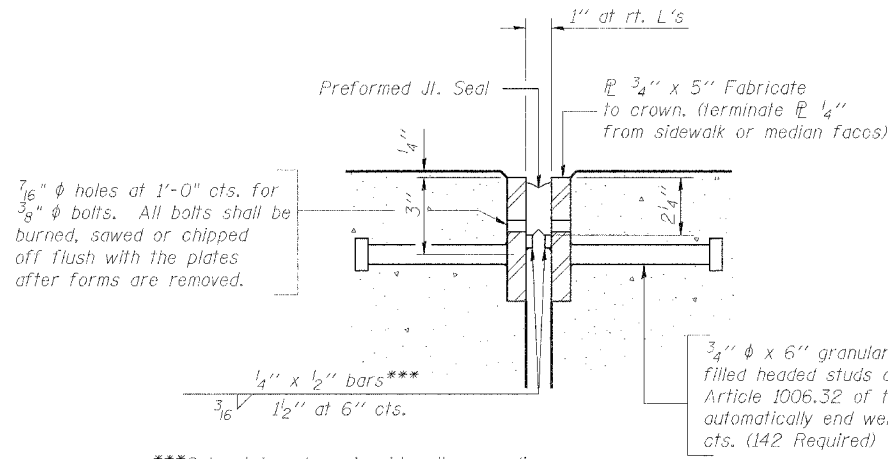

\*\*\*Cut retainer bars in sidewalk or median 6" short of the sidewalk or median face.

**SECTION THRU FIXED PREFORMED JOINT SEAL (NORTH ABUTMENT)**

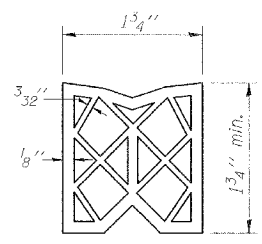

**PREFORMED JOINT SEAL**

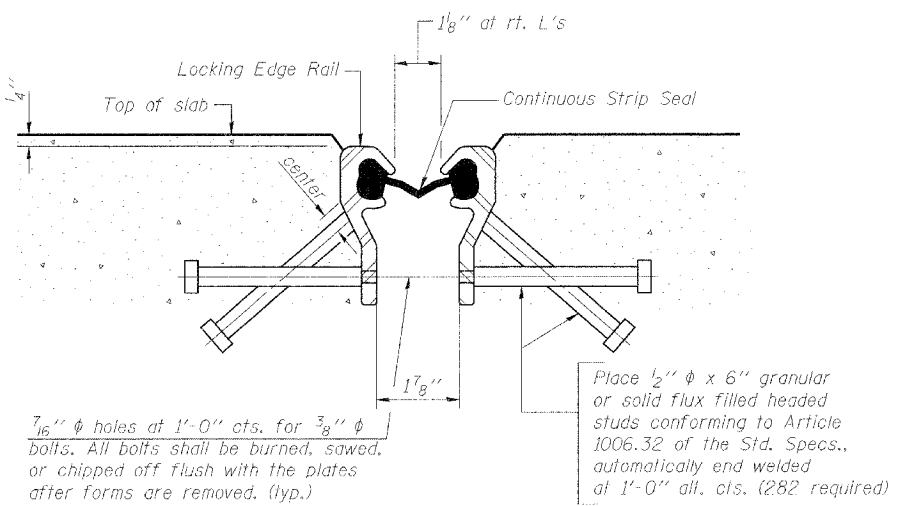

**SECTION THRU FIXED STRIP SEAL JOINT (NORTH ABUTMENT)**

**GENERAL NOTES**

Furnish PJS steel plates in segments of 20 feet maximum length. Maximum space between installed segments shall be 3/16 inch. Seal space with silicone sealant suitable for structural steel.

The strip seal shall be made continuous and shall have a minimum thickness of 1/4 inch. The configuration of the strip seal shall match the configuration of the Locking Edge Rails.

The height and thickness of the Locking Edge Rails shown are minimum dimensions. The actual configuration of the Locking Edge Rails and matching strip seal may vary from manufacturer to manufacturer. Flanged edge rails will not be allowed.

Locking Edge Rails may be spliced at slope discontinuities and stage construction joints.

The manufacturer's recommended installation methods shall be followed.

The joint opening and deck dimensions detailed on the superstructure are based on a preformed joint seal. If the contractor elects to use the alternate strip seal joint, the opening and deck dimensions shall be modified according to the dimensions detailed on this sheet. Required modifications shall be made at no additional cost to the State.

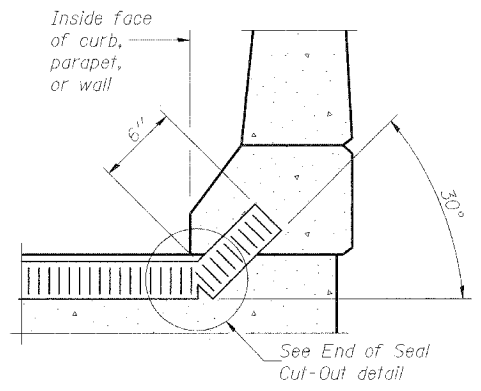

**AT CURB, PARAPET, OR WALL (Showing seal)**

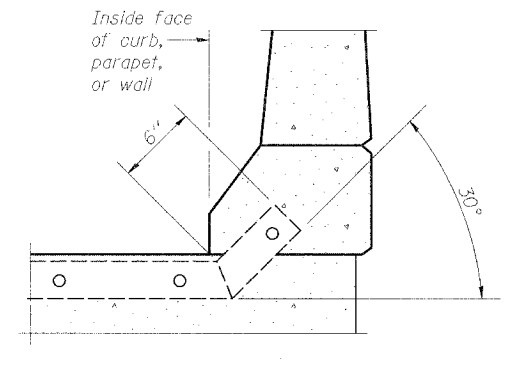

**AT CURB, PARAPET, OR WALL (Showing plate)**

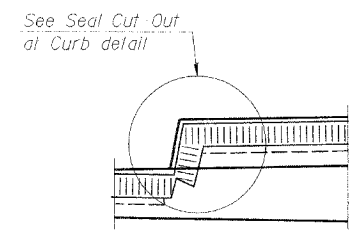

**AT SIDEWALK OR MEDIAN**

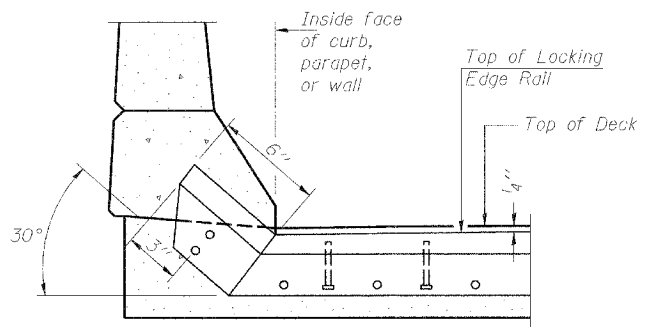

**AT CURB, PARAPET, OR WALL**

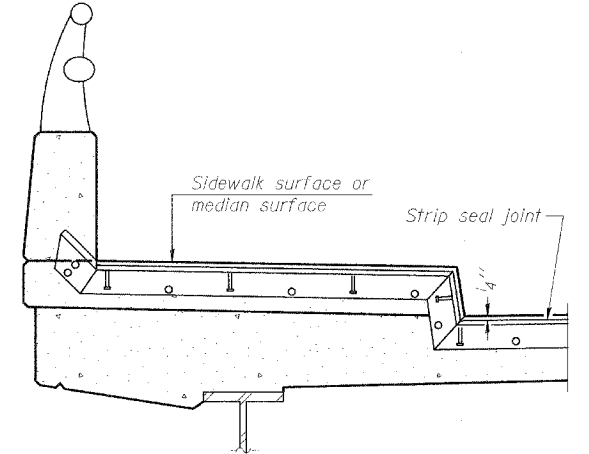

**AT SIDEWALK OR MEDIAN**

**TYPICAL END TREATMENTS FOR STRIP SEAL**

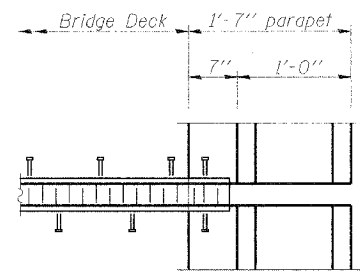

**PLAN AT PARAPET**

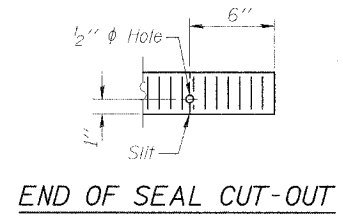

**END OF SEAL CUT-OUT**

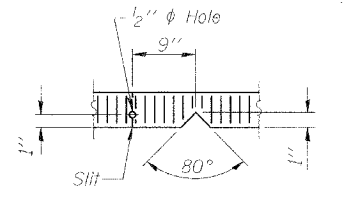

**SEAL CUT-OUT AT CURB**

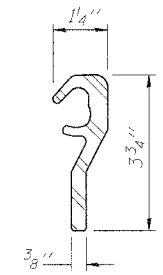

**LOCKING EDGE RAIL**

The inside of the Locking Edge Rail groove shall be free of weld residue.

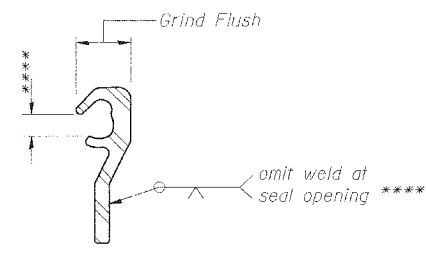

**LOCKING EDGE RAIL SPLICE**

**BILL OF MATERIAL**

Item	Unit	Total
Bridge Joint System (Fixed)	Foot	73

**BRIDGE JOINT SYSTEM - FIXED**

**CG** Ciorba Group, Inc.  
CONSULTING ENGINEERS  
607 NORTH COMMERLAND AVENUE - CHICAGO, ILLINOIS 60656 - (773) 775-0099

CITY OF EVANSTON, ILLINOIS  
BRIDGE JOINT SYSTEM-FIXED  
ASBURY AVENUE OVER CTA YELLOW LINE  
SECTION 00-00215-00-BR  
COOK COUNTY  
STA. 103+20.00  
STRUCTURE NO. 016-6959

REVISIONS	
NAME	DATE

SCALE: NONE  
DATE: OCTOBER 2004  
FILE: 3212  
DRAWN BY: IMG  
CHECKED BY: SCD

DATE: 10/29/2004  
FILENAME: N:\PROJ\3212\Design\Structural\3212-S-11-S-12-S-13-BridgeJoint.dgn

FJ-BJS 10-31-02