

| DESIGN | | |
|-----------|--------|----|
| INT. DATE | REASON | BY |
| | | |

| PLAN | |
|------|------|
| NO. | DATE |
| | |

| CHECKS | | |
|-----------|--------|----|
| INT. DATE | REASON | BY |
| | | |

| PROFILE | |
|---------|------|
| NO. | DATE |
| | |

| CHECKS | | |
|-----------|--------|----|
| INT. DATE | REASON | BY |
| | | |

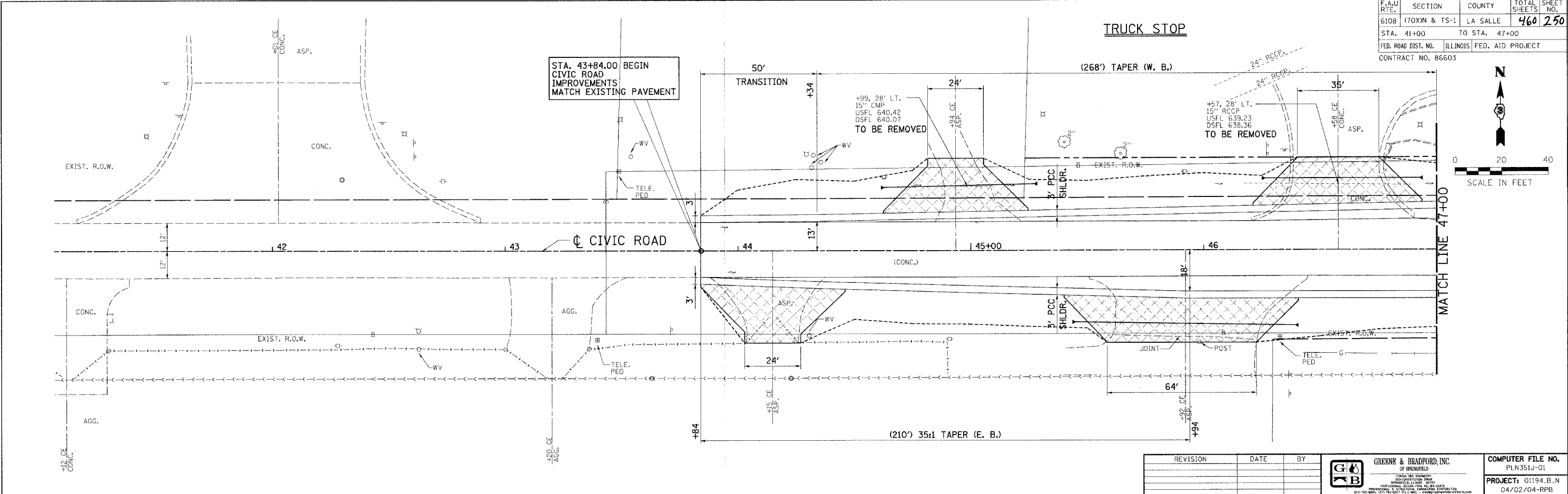

| F.A.U. RTE. | SECTION | COUNTY | TOTAL SHEETS | SHEET NO. |
|--------------------------|--------------|---------------------------|--------------------|-----------|
| 6108 | (70XN & TS-1 | LA SALLE | 460 | 250 |
| STA. 41+00 TO STA. 47+00 | | ILLINOIS FED. AID PROJECT | CONTRACT NO. 86603 | |

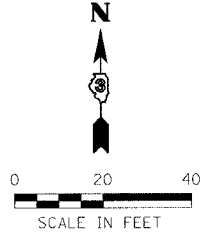

| REVISION | DATE | BY |
|----------|------|----|
| | | |

GREENE & BRADFORD, INC.
OF SPRINGFIELD
CONSULTING ENGINEERS
CIVIL ENGINEERS
REGISTERED IN ILLINOIS
OFFICE: 1000 E. WASHINGTON ST., SPRINGFIELD, ILLINOIS 62761
PHONE: (217) 528-8800 FAX: (217) 528-8801
WWW.GREENE-AND-BRADFORD.COM

| COMPUTER FILE NO. |
|-------------------|
| PLN351J-01 |

PROJECT: 01194.B.N
04/02/04-RPB

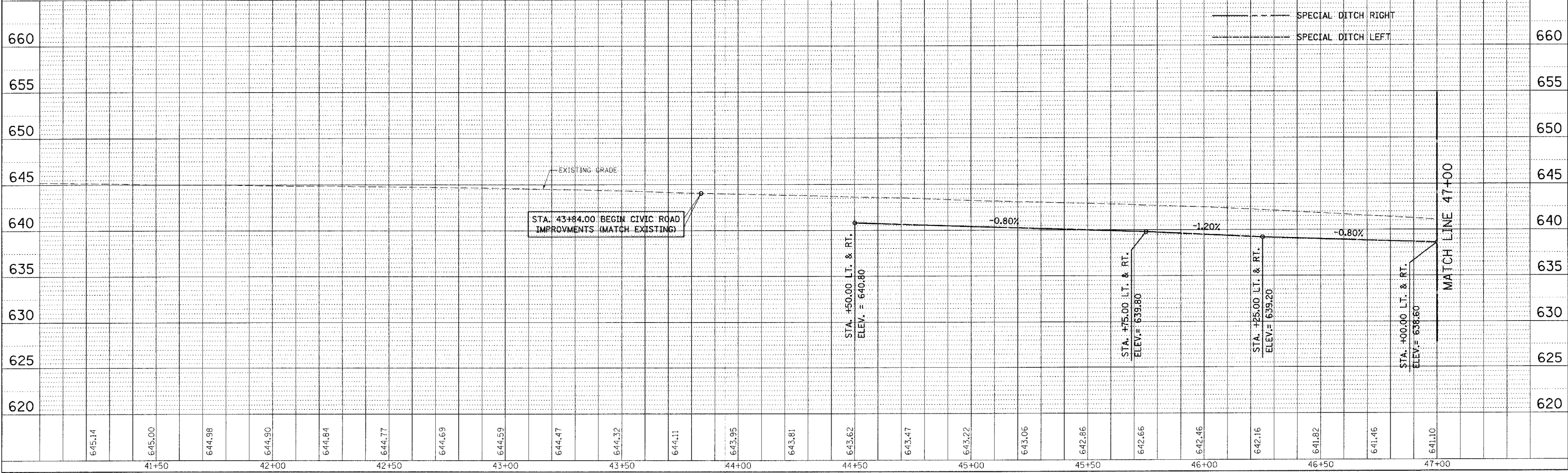

IDOTEPP - 1a 8/25/98

CIVIC RD. WEST - FAU RTE. 6108 (IL. RTE. 351) LA SALLE CO.