

- NOTES:**
1. ALL DIMENSIONS ARE IN INCHES (MILLIMETERS) UNLESS OTHERWISE SHOWN.
 2. MOUNTING HEIGHT IS DEFINED AS THE DISTANCE FROM THE CENTERLINE OF THE TENON TO THE BOTTOM OF THE ANCHOR BASE.
 3. THE LIGHT POLE WILL MEET AASHTO DESIGN CRITERIA AS SPECIFIED.
 4. THE INSTALLING CONTRACTOR WILL PROVIDE A UL LISTED GROUNDING CONNECTOR, BURNDY K2C23, T&B SP4DL OR APPROVED EQUAL.
 5. LIGHT POLES WILL NOT BE INSTALLED WITHOUT MAST ARMS AND LUMINAIRES.
 6. LIGHT POLES WILL BE SET PLUMB ON THE FOUNDATION WITHOUT THE USE OF LEVELING NUTS, WASHERS OR SHIMS.
 7. LIGHTING UNIT IDENTIFICATION NUMBERS SHALL BE INSTALLED BEFORE THE LIGHTING UNIT IS ENERGIZED.

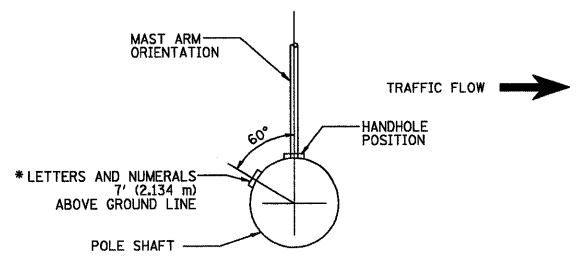

POSITION OF HANDHOLE AND POLE NUMBER FOR SINGLE MAST ARM POLES MOUNTED ON BRIDGE PARAPET OR BARRIER WALL

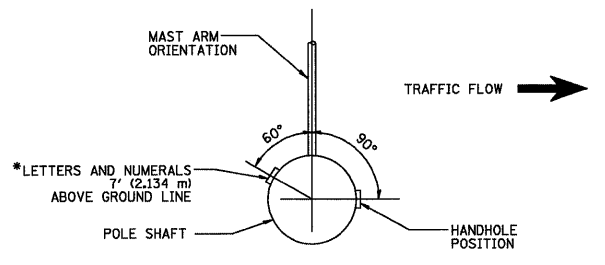

POSITION OF HANDHOLE AND POLE NUMBER FOR SINGLE MAST ARM POLES

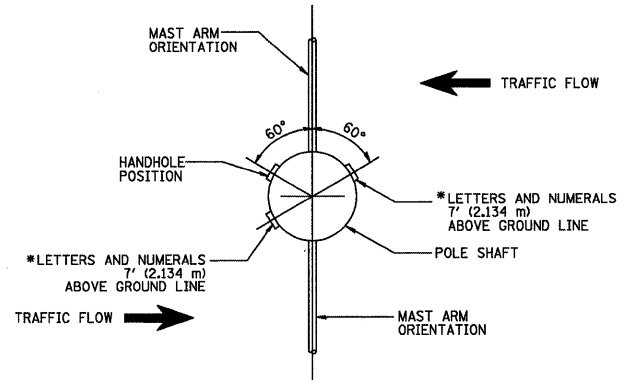

POSITION OF HANDHOLE AND POLE NUMBER FOR TWIN MAST ARM POLES

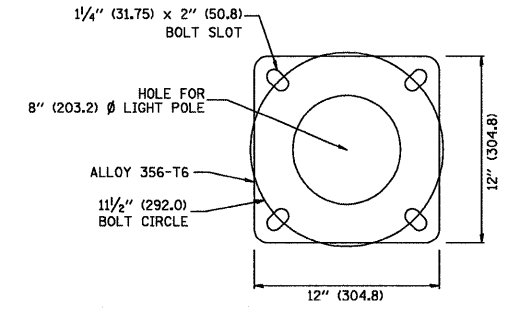

LIGHT POLE BASE PLATE DETAIL
1 1/2" (292.0) BOLT CIRCLE

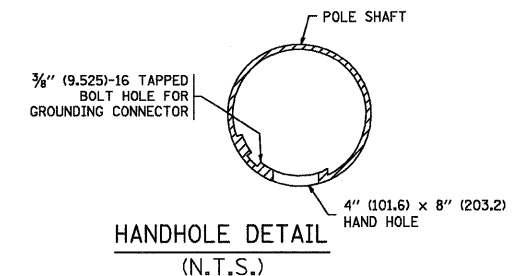

**ALUMINUM LIGHT POLE
35'-0" (10.668 m) MOUNTING HEIGHT**

BE-402, LATEST REVISION DATE: 09-02-03

FILE NAME = 4085.867-872-DT1.dwg	USER NAME = ZACH WALLSTEN	DESIGNED - JRD	REVISED -
		DRAWN - ZCW	REVISED -
		CHECKED - KLB	REVISED -
		DATE - 10/29/2010	REVISED -

**STATE OF ILLINOIS
DEPARTMENT OF TRANSPORTATION**

DISTRICT 1 STANDARD DETAILS		FAP. RTE.	SECTION	COUNTY	TOTAL SHEETS	SHEET NO.
SCALE N.A.		VARIES	2010-006TS	COOK	58	58
SHEET NO. OF SHEETS		TO STA.		CONTRACT #: 60K24		

GHA #4085.867-872					
FAP. RTE.	SECTION	COUNTY	TOTAL SHEETS	SHEET NO.	
VARIES	2010-006TS	COOK	58	58	
BE-402			CONTRACT #: 60K24		
ILLINOIS FED. AID PROJECT					