

TOP VIEW

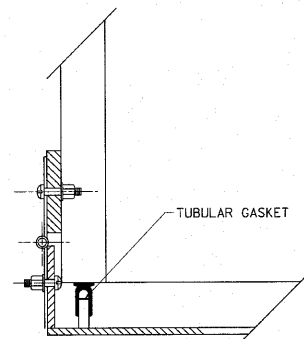

HINGE DETAIL

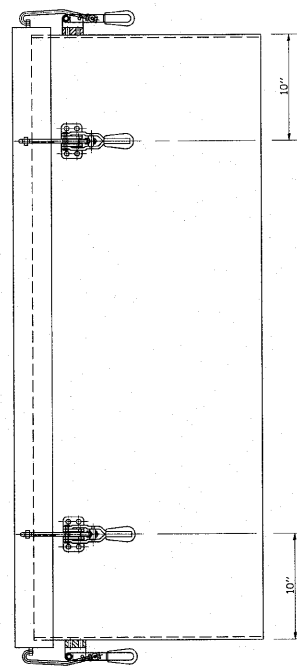

SIDE VIEW

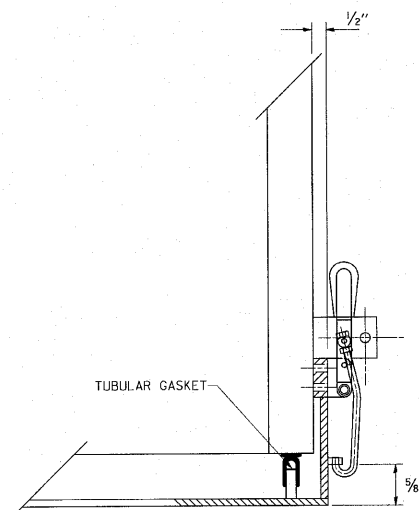

LATCH DETAIL

HANDHOLE DOOR DETAILS

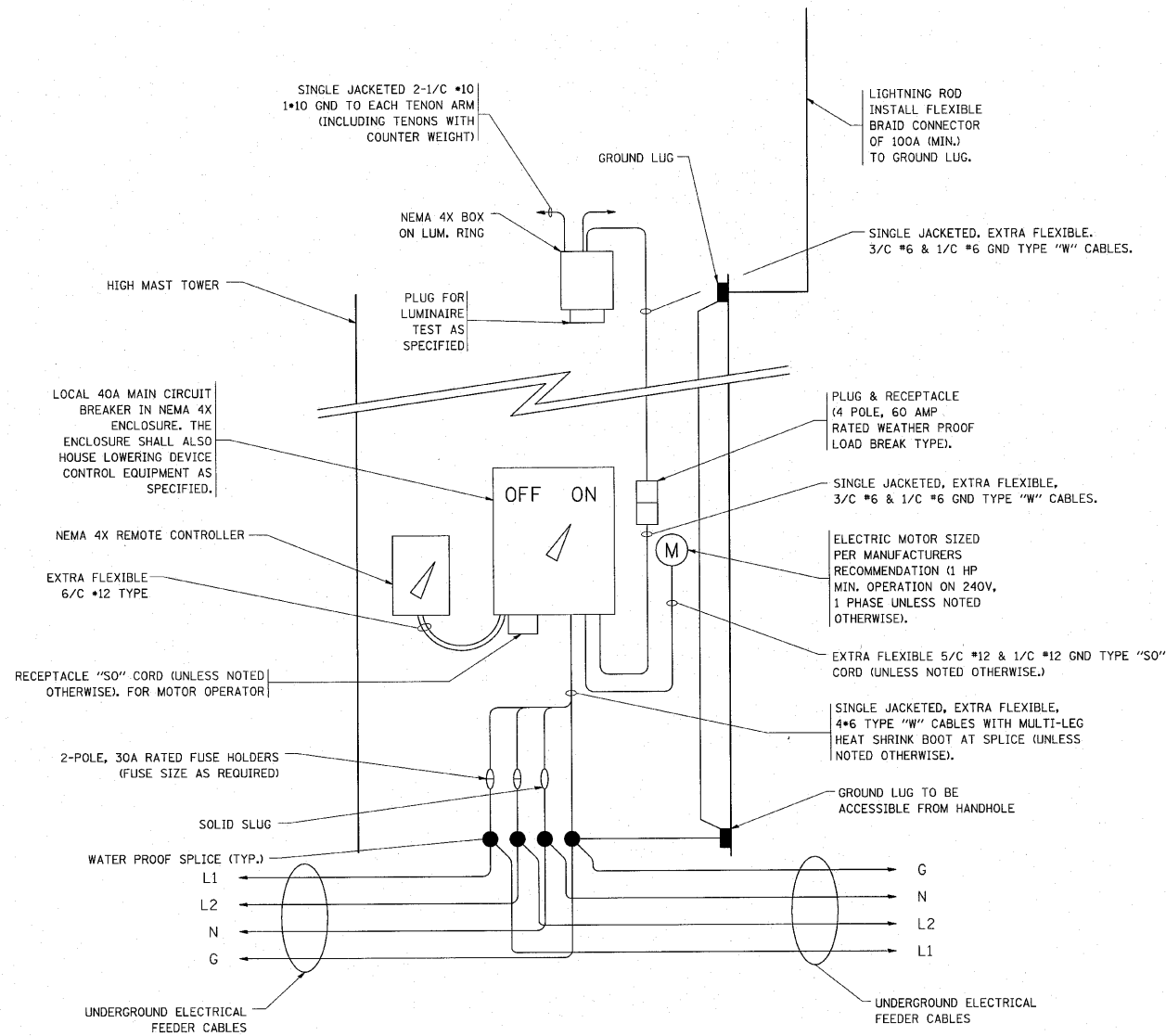

HIGH MAST POLE WIRING DIAGRAM

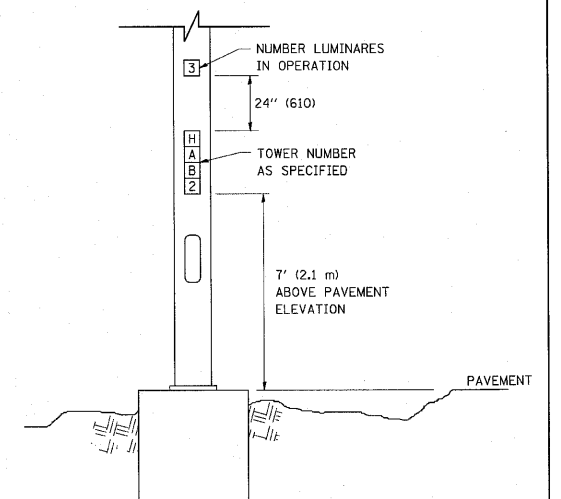

LIGHT TOWER NUMBERING DETAIL

FILE NAME =	USER NAME =	DESIGNED -	REVISED -
		DRAWN -	REVISED -
		CHECKED -	REVISED -
		DATE -	REVISED -

STATE OF ILLINOIS  
DEPARTMENT OF TRANSPORTATION

HIGH MAST LIGHT TOWER  
90 FT TO 120 FT (27 m TO 36 m)

SCALE: NONE SHEET NO. 3 OF 3 SHEETS STA. TO STA.

F.A. RTE.	SECTION	COUNTY	TOTAL SHEETS	SHEET NO.
3537	(4Y&22-3)R-2	DuPage	284	159
BE-500		CONTRACT NO. D-91-533-00		
FED. ROAD DIST. NO. 1 ILLINOIS FED. AID PROJECT				