

STATE OF ILLINOIS  
DEPARTMENT OF TRANSPORTATION

ROUTE NO.	SECTION	COUNTY	MILES	SHEET NO.	SHEET NO.
353	(12&13)WRS-4	Will	608	471	13 SHEETS
FED. ROAD DIST. NO. 7		ILLINOIS	FED. AID PROJECT		Contract No. 62478

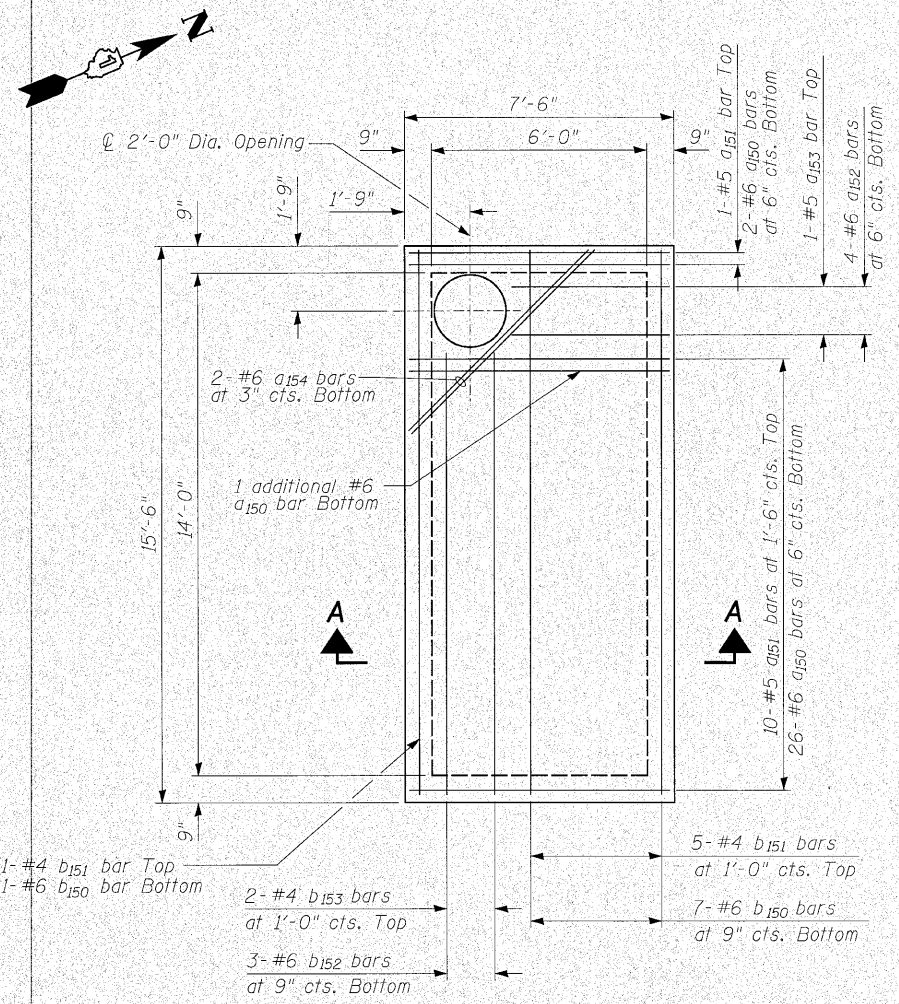

**TOP SLAB PLAN**

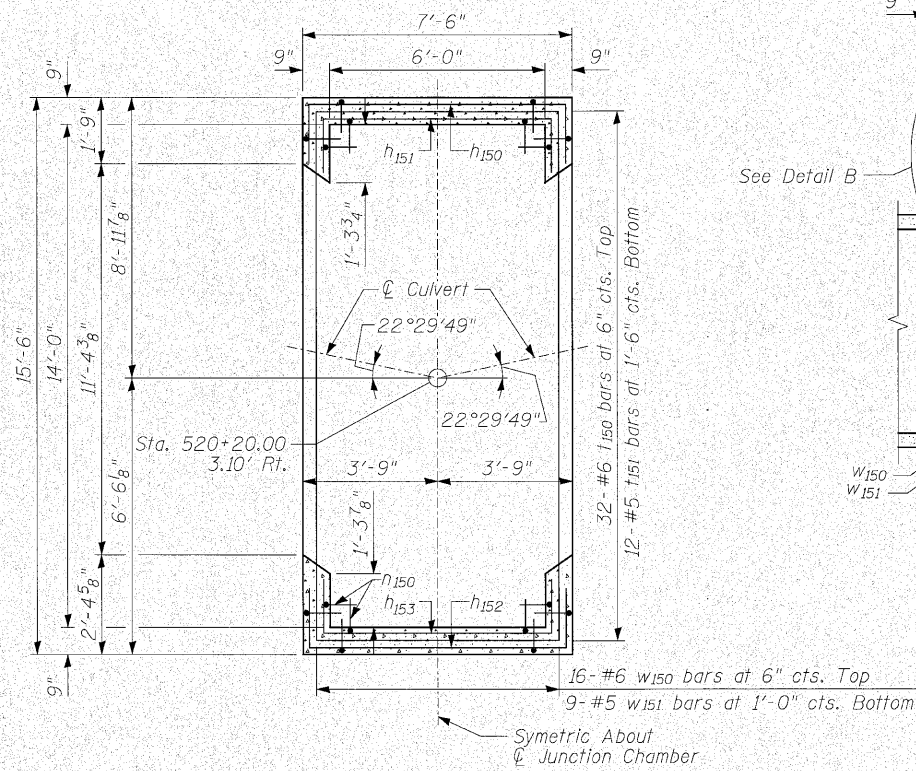

**BOTTOM SLAB PLAN**

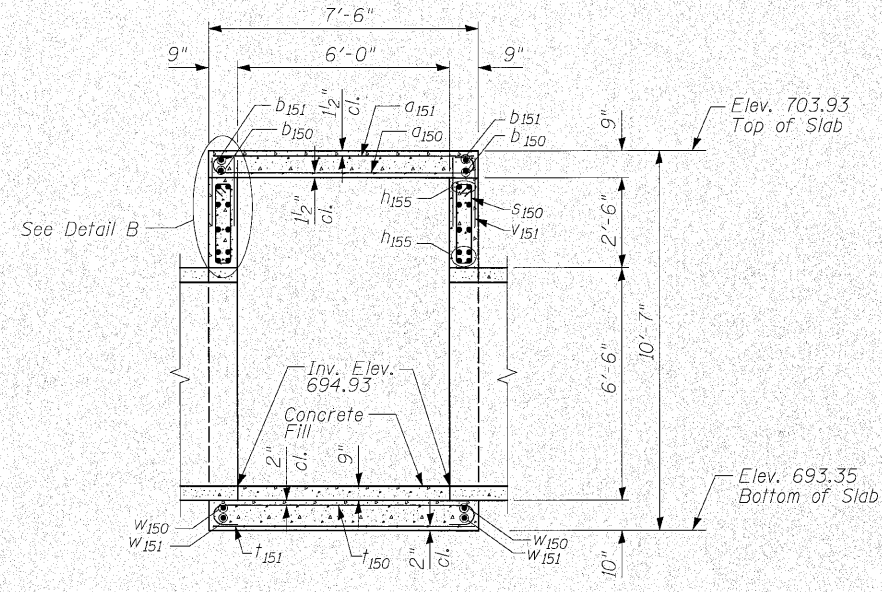

**SECTION A-A**

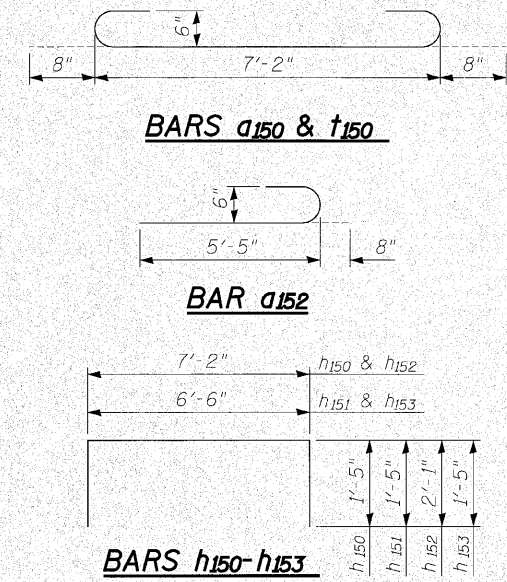

**BILL OF MATERIAL**

Bar	No.	Size	Length	Shape
a150	29	#6	8'-6"	[C]
a151	11	#5	7'-2"	[C]
a152	4	#6	6'-1"	[C]
a153	1	#5	5'-5"	[C]
a154	2	#6	6'-10"	[C]
b150	8	#6	15'-2"	[C]
b151	6	#4	15'-2"	[C]
b152	3	#6	13'-5"	[C]
b153	2	#4	13'-5"	[C]
h150	10	#5	10'-0"	[C]
h151	10	#5	9'-4"	[C]
h152	10	#5	11'-4"	[C]
h153	10	#5	9'-4"	[C]
h154	16	#5	2'-0"	[C]
h155	20	#8	15'-2"	[C]
n150	64	#5	3'-10"	[C]
s150	48	#4	6'-3"	[C]
t150	32	#6	8'-6"	[C]
t151	12	#5	7'-2"	[C]
v150	64	#5	9'-6"	[C]
v151	96	#4	1'-10"	[C]
w150	16	#6	15'-2"	[C]
w151	9	#5	15'-2"	[C]
Concrete Structures			Cu. Yd.	15.7
Reinforcement Bars			Pound	4,310

Note:  
Quantity of Concrete Structures and Reinforcement Bars is shown for information only.

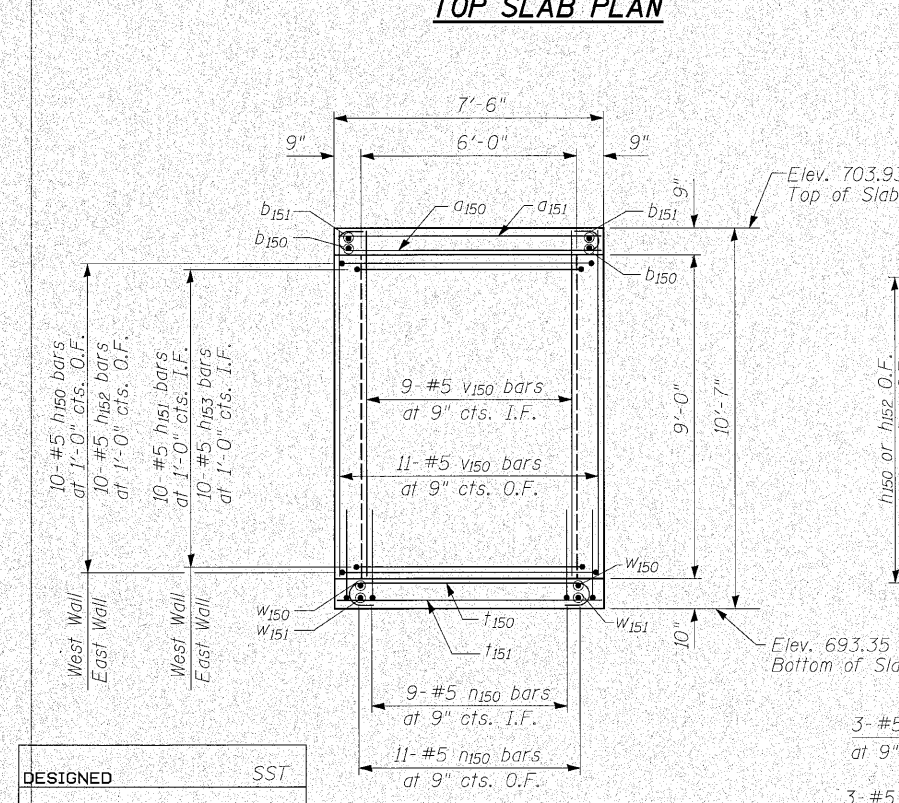

**WEST WALL ELEVATION  
EAST WALL ELEVATION**

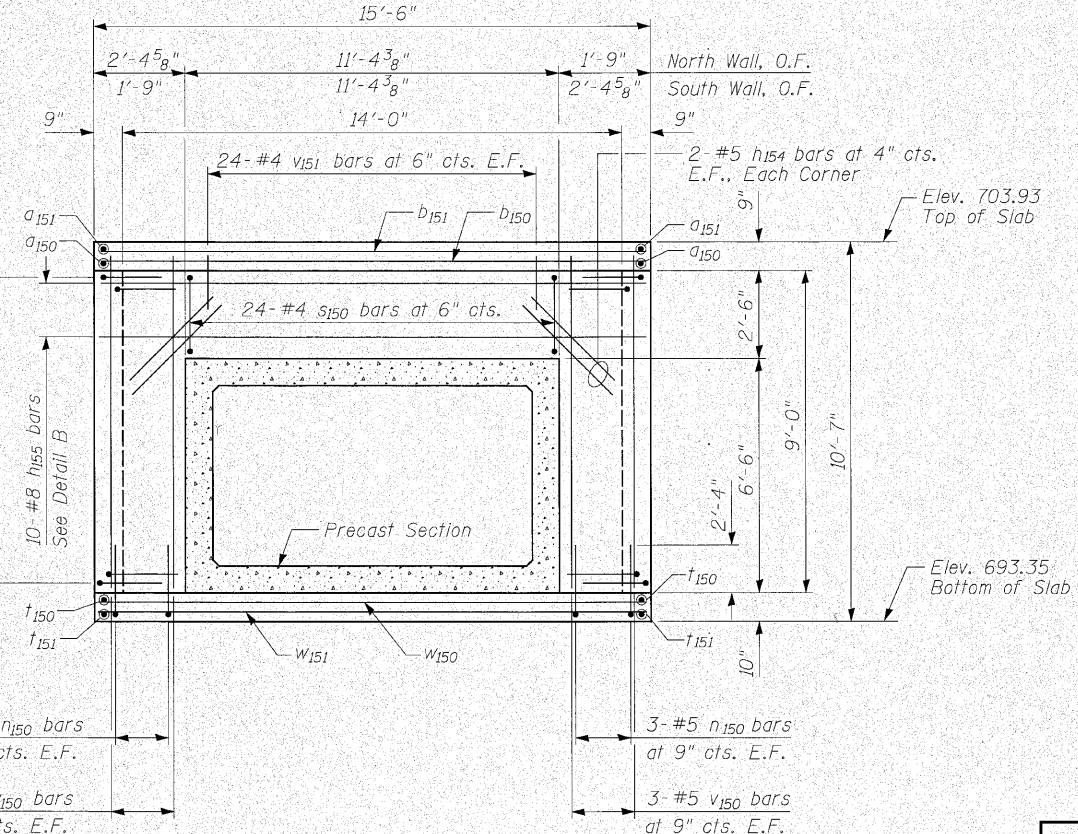

**NORTH WALL ELEVATION  
SOUTH WALL ELEVATION**

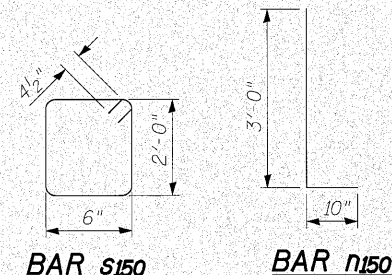

**DETAIL B**

DESIGNED	SST
CHECKED	SPK
DRAWN	JHP
CHECKED	SST

**INFRASTRUCTURE ENGINEERING** | INCORPORATED  
33 West Monroe | Suite 1540 | Chicago, IL 60603  
P 312.425.9560 | F 312.425.9584 | www.infrastructure-eng.com

**JUNCTION CHAMBER NO. 8**  
**U.S. ROUTE 30 AND HILLSIDE ROAD OVER**  
**TRIBUTARY TO HICKORY CREEK**  
**F.A.P. ROUTE 353 SEC. (12&13)WRS-4**  
**WILL COUNTY**  
**STATION 520+20.00**  
**STRUCTURE NO. 099-C027**

P:\P\_03\1505\Drawings\Final Design\20-20-00\Drawings\Sheets\culv520-stn09-C027.dwg 3:59:02 PM 6/9/2010