

STATE OF ILLINOIS
DEPARTMENT OF TRANSPORTATION

ROUTE NO.	SECTION	COUNTY	TOTAL SHEETS	SHEET NO.
353	(12&13)WRS-4	Will	608	464
SHEETS 9				

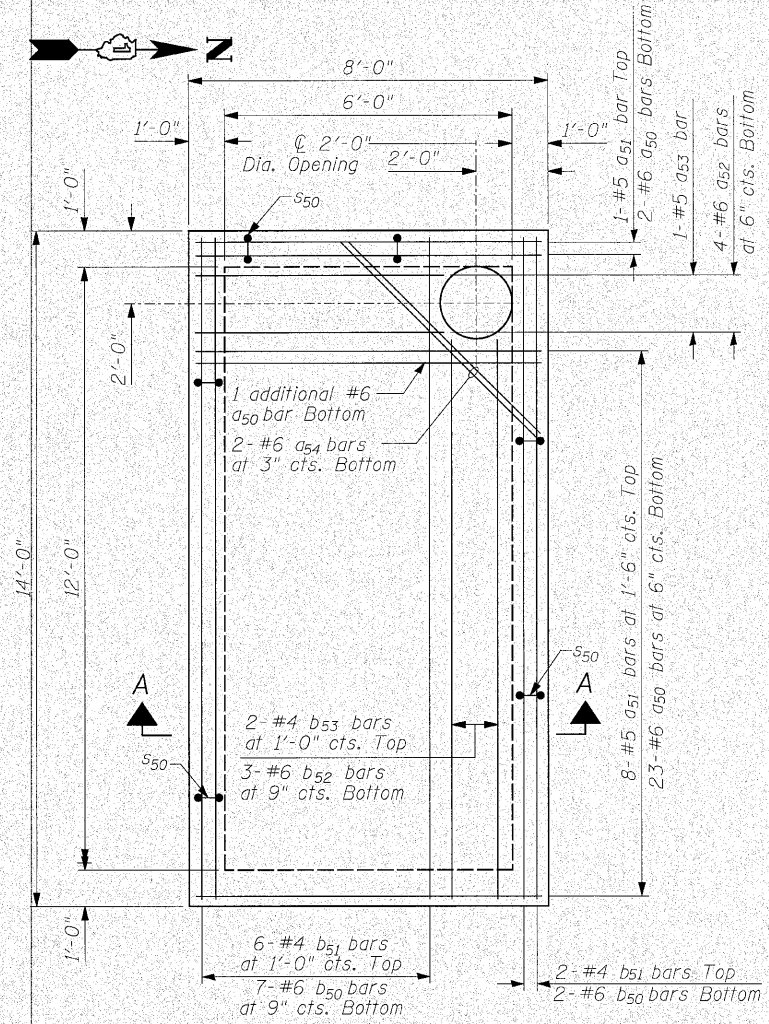

TOP SLAB PLAN

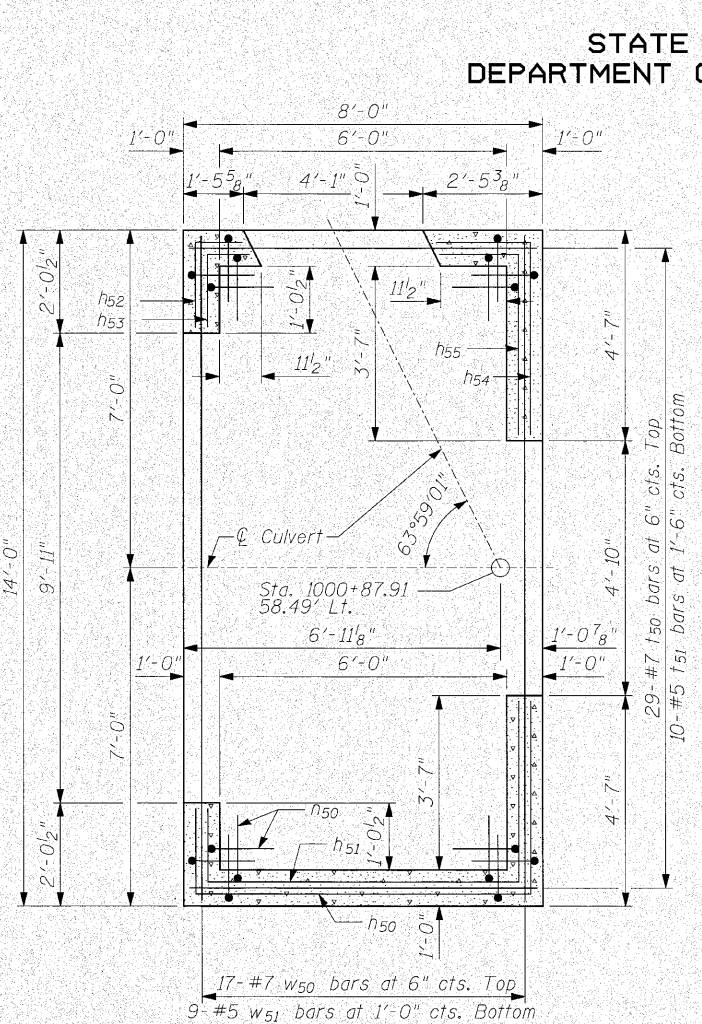

BOTTOM SLAB PLAN

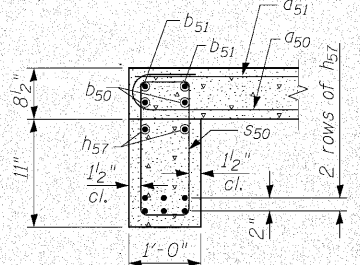

DETAIL B

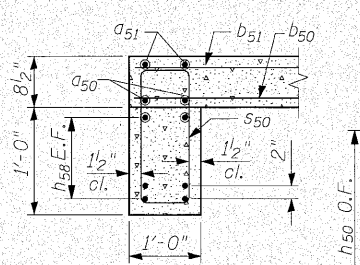

SECTION C-C

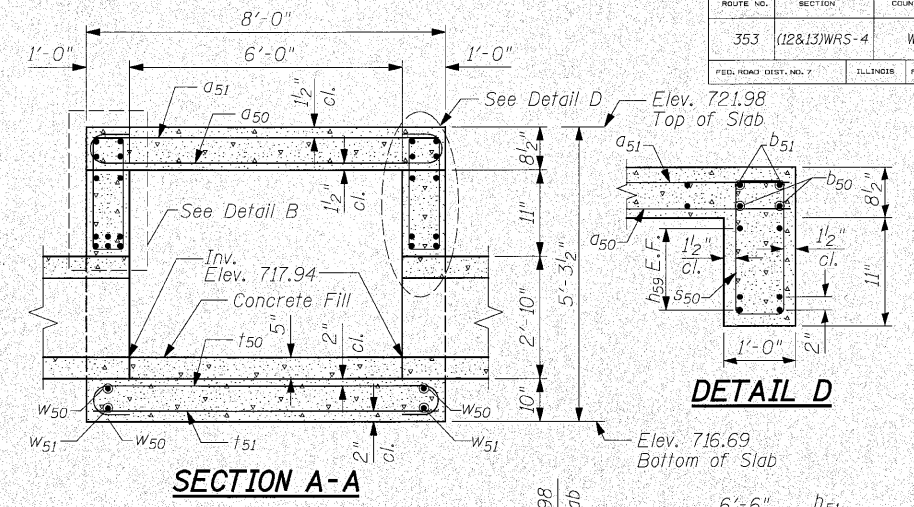

SECTION A-A

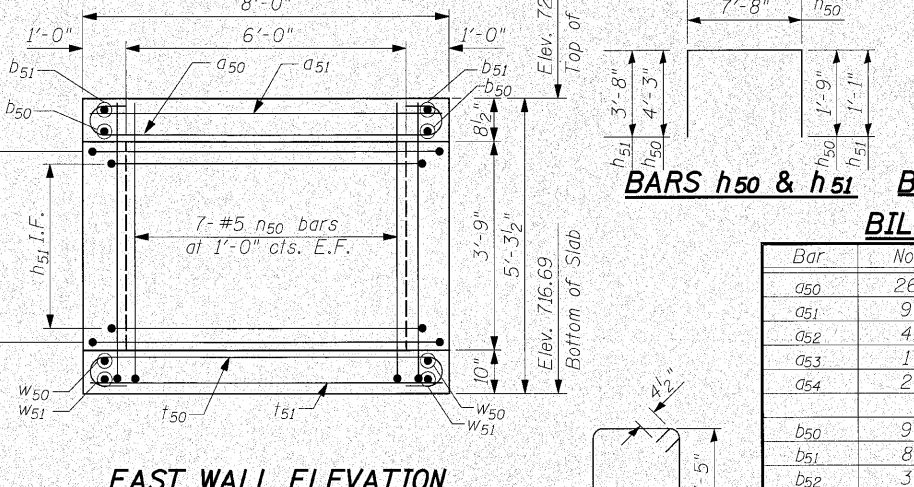

EAST WALL ELEVATION

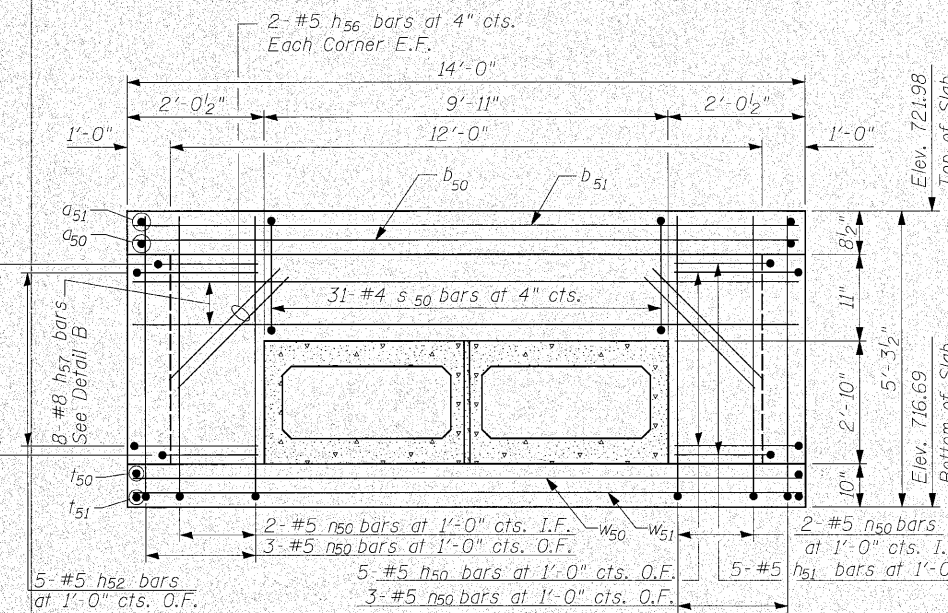

SOUTH WALL ELEVATION

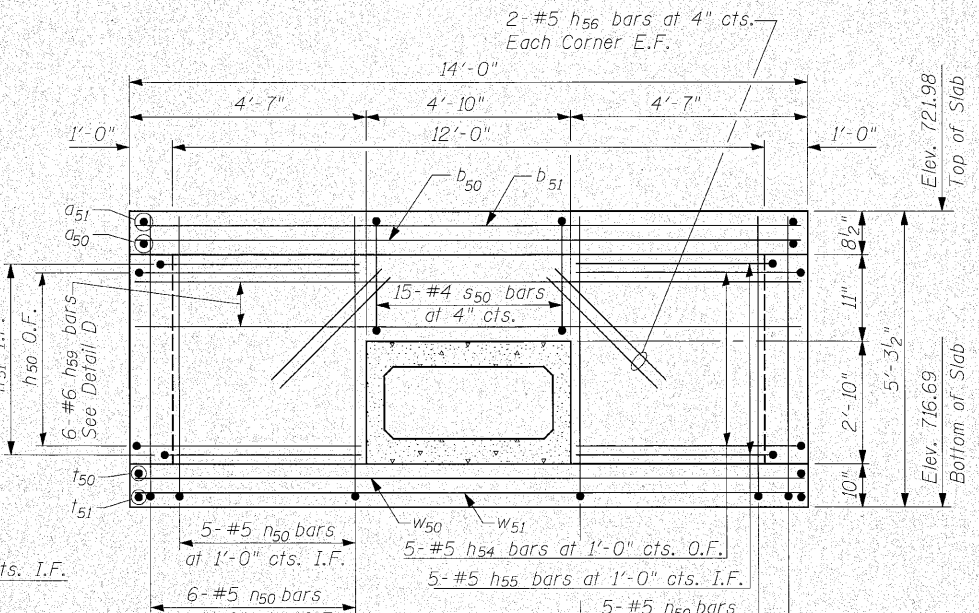

NORTH WALL ELEVATION

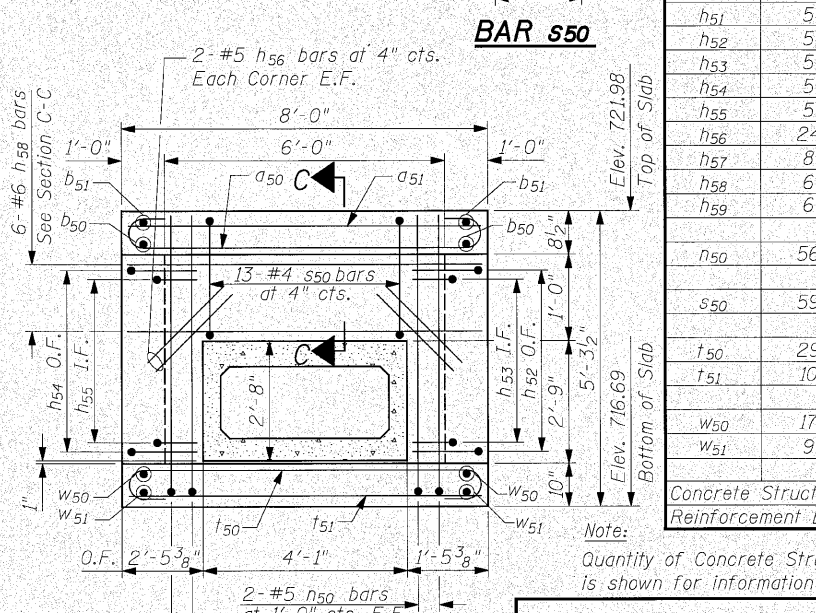

WEST WALL ELEVATION

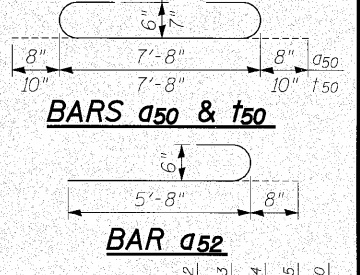

DETAIL D

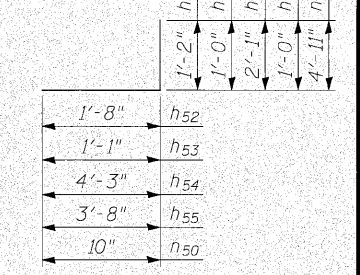

BILL OF MATERIAL

Bar No.	Size	Length	Shape
a ₅₀	26	#6	9'-0"
a ₅₁	9	#5	7'-8"
a ₅₂	4	#6	6'-4"
a ₅₃	1	#5	5'-8"
a ₅₄	2	#6	8'-0"
b ₅₀	9	#6	13'-8"
b ₅₁	8	#4	13'-8"
b ₅₂	3	#6	11'-8"
b ₅₃	2	#4	11'-8"
h ₅₀	5	#5	14'-8"
h ₅₁	5	#5	11'-3"
h ₅₂	5	#5	2'-10"
h ₅₃	5	#5	2'-1"
h ₅₄	5	#5	6'-4"
h ₅₅	5	#5	4'-8"
h ₅₆	24	#5	2'-0"
h ₅₇	8	#8	13'-8"
h ₅₈	6	#6	7'-8"
h ₅₉	6	#6	13'-8"
n ₅₀	56	#5	5'-9"
s ₅₀	59	#4	5'-1"
t ₅₀	29	#7	9'-4"
t ₅₁	10	#5	7'-8"
w ₅₀	17	#7	13'-8"
w ₅₁	9	#5	13'-8"

Concrete Structures Cu. Yd. 11.0
Reinforcement Bars Pound 3,340

JUNCTION CHAMBER NO. 11
U.S. ROUTE 30 OVER
DRAINAGE DITCH
F.A.P. ROUTE 353 SEC. (12&13)WRS-4
WILL COUNTY
STATION 579+38.78
STRUCTURE NO. 099-C028

INFRASTRUCTURE ENGINEERING | INCORPORATED
33 West Monroe | Suite 1540 | Chicago, IL 60603
P 312.425.9560 | F 312.425.9584 | www.infrastructure-eng.com

P:\P-03\1505\Drawings\Final_Design\37913878\Drawings\Sheets\c1v579-shd0301.dgn 3/5/2010 3:53:30 PM

DESIGNED	SST
CHECKED	SPK
DRAWN	JHP
CHECKED	SST