

STATE OF ILLINOIS  
DEPARTMENT OF TRANSPORTATION

ROUTE NO.	SECTION	COUNTY	SHEET NO.	SHEET NO.
353	(12&13)WRS-4	Will	608	486
FED. ROAD DIST. NO. 7		ILLINOIS	FED. AID PROJECT	
Contract No. 6247B				

**GENERAL NOTES**

1. Precast concrete box culvert sections shall conform to the requirements of Article 540.06 of the Standard Specifications and the applicable requirements of either AASHTO M259 or M273 as applicable.
2. Lifting holes shall be filled with concrete plugs and mastic after box sections are in place.
3. Reinforcement bars shall conform to the requirements of ASTM A 706 Grade 60. See Special Provisions.
4. All construction joints of cast-in-place concrete elements shall be bonded.
5. The limits and quantities of removal and replacement shown are based on the boring data and may be modified by the District Geotechnical and Field Engineers for variable subsurface conditions encountered in the field.

**ABBREVIATIONS**

CL	centerline
CMP	corrugated metal pipe
cts.	centers
DS	downstream
Elev.	elevation
Inv.	invert
O.	out
NB	Northbound
PGL	profile grade line
R.O.W.	right-of-way
SB	Southbound
Sta.	station
typ.	typical
US	up stream

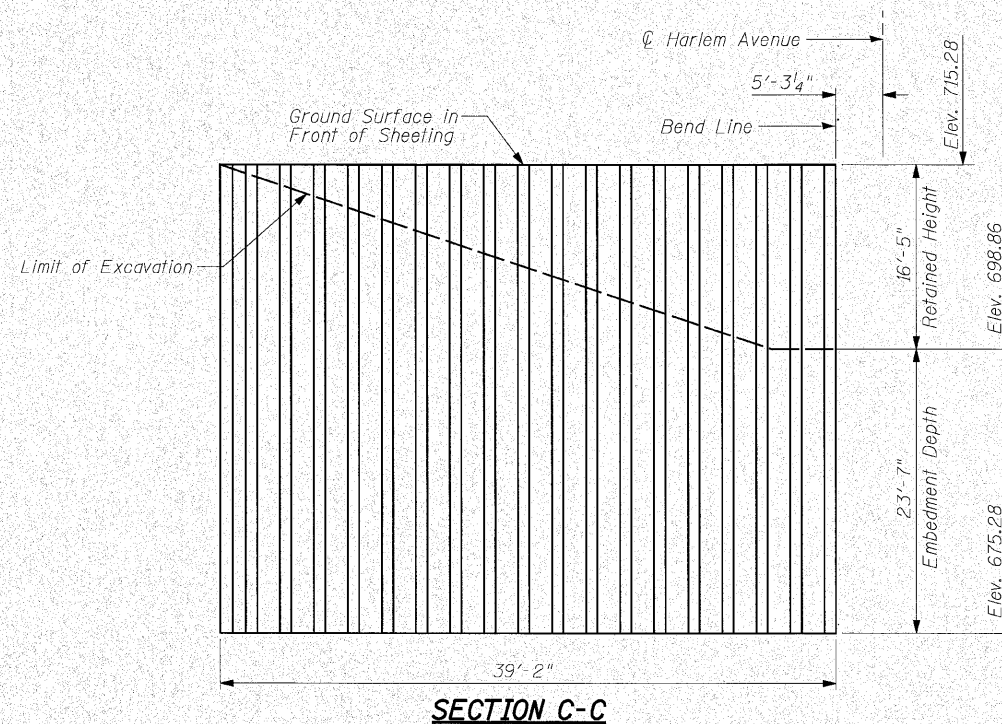
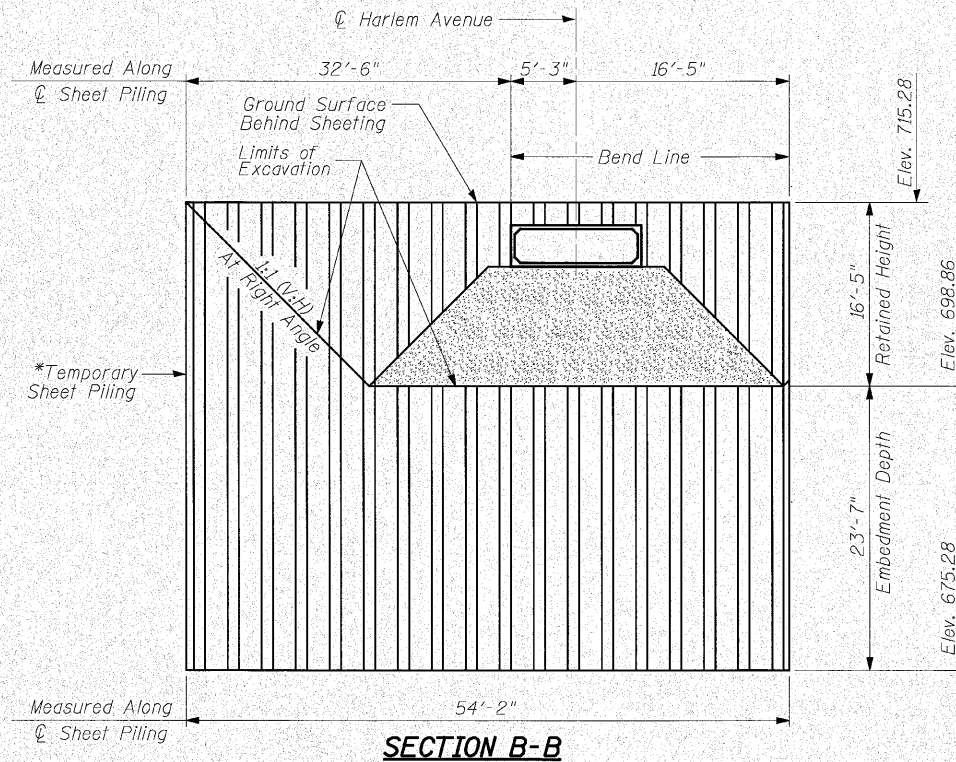

**NOTES:**

- If the Contractor chooses to alter the temporary cantilevered sheet piling design requirements shown on the plans a design submittal including plan details and calculations will be required for review and acceptance by the Engineer.
- \*Minimum section modulus per linear foot of sheet piling = 51.7 in<sup>3</sup>/ft.

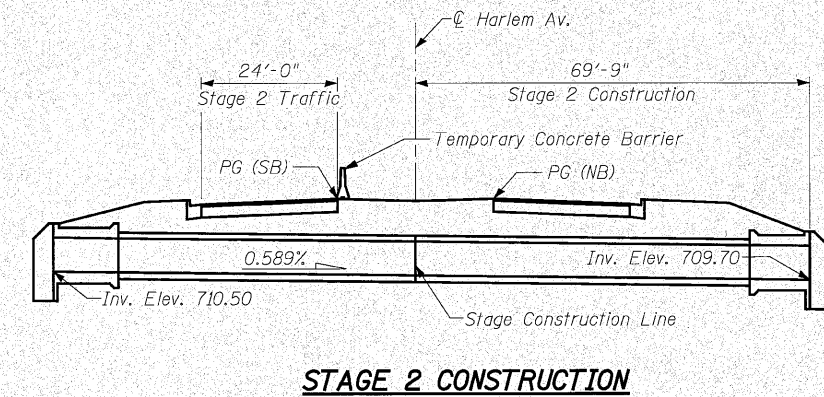
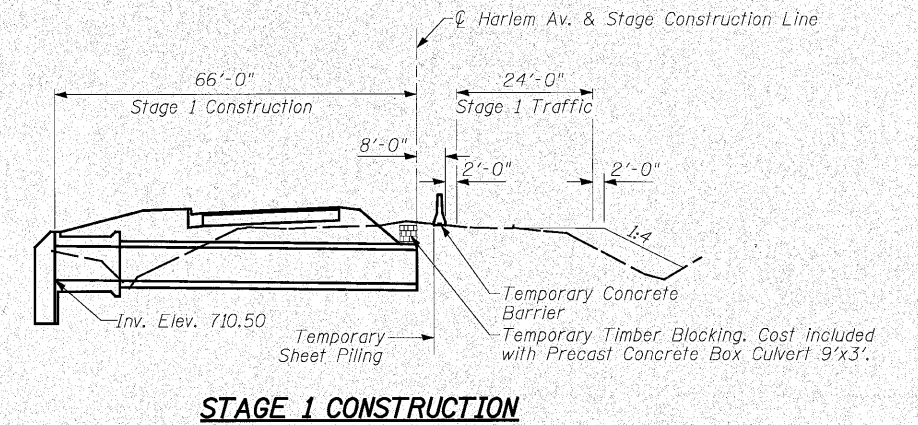

DESIGNED	SST
CHECKED	SPK
DRAWN	BID
CHECKED	SPK

**INFRASTRUCTURE ENGINEERING** | INCORPORATED  
33 West Monroe | Suite 1540 | Chicago, IL 60603  
P 312.425.9560 | F 312.425.9564 | www.infrastructure-eng.com

**GENERAL NOTES, STAGING & TEMPORARY SHEET PILING HARLEM AVENUE OVER DRAINAGE DITCH**  
F.A.P. ROUTE 353 - SEC. (12&13)WRS-4  
WILL COUNTY  
STATION 991+37.00  
STRUCTURE NO. 099-C028

P:\P-03\15605\Drawings\Final Design\991+37.00\Drawings\Sheets\Culvert\991-sh02.dwg 2/26/2010 2:15:37 PM