

STATE OF ILLINOIS
DEPARTMENT OF TRANSPORTATION

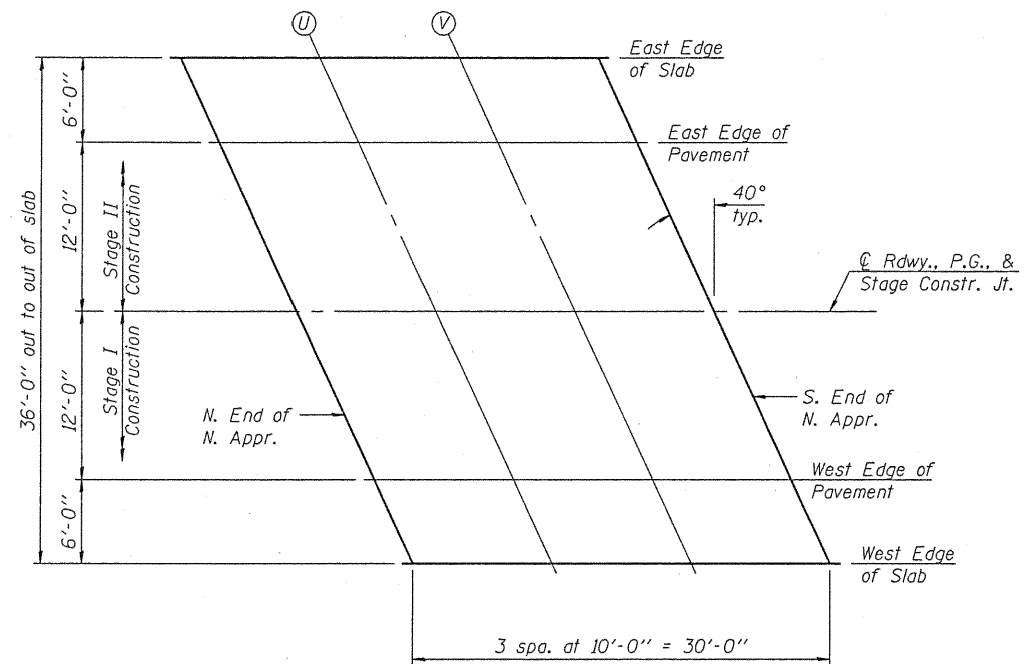

PLAN - NORTH APPROACH

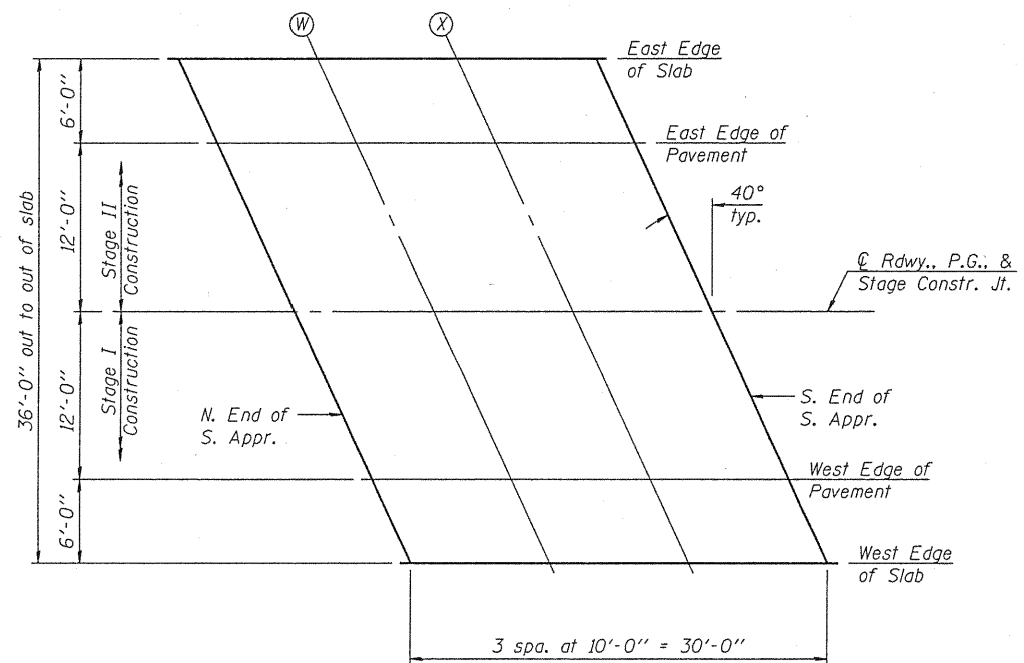

PLAN - SOUTH APPROACH

EAST EDGE OF SLAB

Location	Station	Offset	Theoretical Grade Elevations
N. End of N. Appr.	1178+10.05	-18.00	666.99
U	1178+20.05	-18.00	666.83
V	1178+30.05	-18.00	666.68
S. End of N. Appr.	1178+40.05	-18.00	666.55
N. End of S. Appr.	1180+69.75	-18.00	667.18
W	1180+79.75	-18.00	667.37
X	1180+89.75	-18.00	667.58
S. End of S. Appr.	1180+99.75	-18.00	667.80

WEST EDGE OF PAVEMENT

Location	Station	Offset	Theoretical Grade Elevations
N. End of N. Appr.	1178+35.22	12.00	666.74
U	1178+45.22	12.00	666.62
V	1178+55.22	12.00	666.51
S. End of N. Appr.	1178+65.22	12.00	666.42
N. End of S. Appr.	1180+94.92	12.00	667.82
W	1181+04.92	12.00	668.05
X	1181+14.92	12.00	668.30
S. End of S. Appr.	1181+24.92	12.00	668.56

EAST EDGE OF PAVEMENT

Location	Station	Offset	Theoretical Grade Elevations
N. End of N. Appr.	1178+15.08	-12.00	667.03
U	1178+25.08	-12.00	666.88
V	1178+35.08	-12.00	666.74
S. End of N. Appr.	1178+45.08	-12.00	666.62
N. End of S. Appr.	1180+74.78	-12.00	667.40
W	1180+84.78	-12.00	667.60
X	1180+94.78	-12.00	667.82
S. End of S. Appr.	1181+04.78	-12.00	668.05

WEST EDGE OF SLAB

Location	Station	Offset	Theoretical Grade Elevations
N. End of N. Appr.	1178+40.25	18.00	666.55
U	1178+50.25	18.00	666.44
V	1178+60.25	18.00	666.34
S. End of N. Appr.	1178+70.25	18.00	666.26
N. End of S. Appr.	1180+99.95	18.00	667.81
W	1181+09.95	18.00	668.05
X	1181+19.95	18.00	668.30
S. End of S. Appr.	1181+29.95	18.00	668.57

☉ RDWY., P.G., AND STAGE CONSTRUCTION JOINT

Location	Station	Offset	Theoretical Grade Elevations
N. End of N. Appr.	1178+25.15	0.00	667.06
U	1178+35.15	0.00	666.93
V	1178+45.15	0.00	666.81
S. End of N. Appr.	1178+55.15	0.00	666.70
N. End of S. Appr.	1180+84.85	0.00	667.79
W	1180+94.85	0.00	668.01
X	1181+04.85	0.00	668.24
S. End of S. Appr.	1181+14.85	0.00	668.48

TOP OF APPROACH
SLAB ELEVATIONS
STRUCTURE NO. 094-0051



DESIGNED - BAS
CHECKED - KEF
DRAWN - SGM
CHECKED - BAS

SHEET NO. 8 27 SHEETS	F.A.P. RTE.	SECTION	COUNTY	TOTAL SHEETS	SHEET NO.
	310	(28B)BR-1	WARREN	71	32
FED. ROAD DIST. NO. ILLINOIS			FED. AID PROJECT		
CONTRACT NO. 68661					