

PLAN

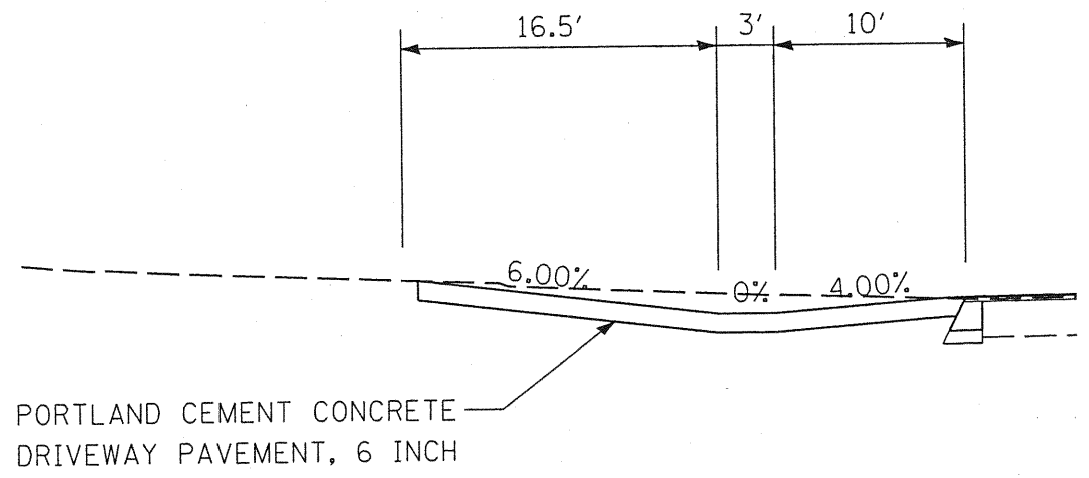

SECTION B-B

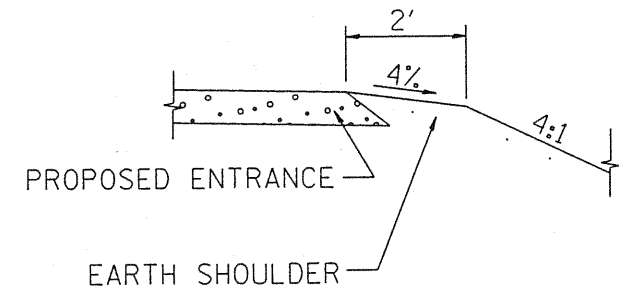

SECTION A-A
SHOULDER TREATMENT FOR RURAL ENTRANCES

GENERAL NOTES

- ENTRANCES SHALL SLOPE AWAY FROM THE PAVEMENT AT A RATE EQUAL TO THE SHOULDER SLOPE FOR A MINIMUM DISTANCE OF 8'.
- A TAPER RATE OF 5:1 IS DESIRABLE WHEN TRANSITING FROM THE RURAL ENTRANCE WIDTH TO THE EXISTING ENTRANCE WIDTH.

STATE OF ILLINOIS DEPARTMENT OF TRANSPORTATION				ENTRANCE DETAIL		F.A.P. RTE. 310		SECTION (28B)BR-1		COUNTY WARREN		TOTAL SHEETS 71		SHEET NO. 55	
												CONTRACT NO. 68661			
												FED. ROAD DIST. NO. ILLINOIS FED. AID PROJECT			

NOT TO SCALE