

Designer NOTES:
 1. Designer to modify this Special Detail sheet, as needed, for inclusion in plans.
 2. Include Highway Standard 280001 "TEMPORARY EROSION CONTROL SYSTEM."

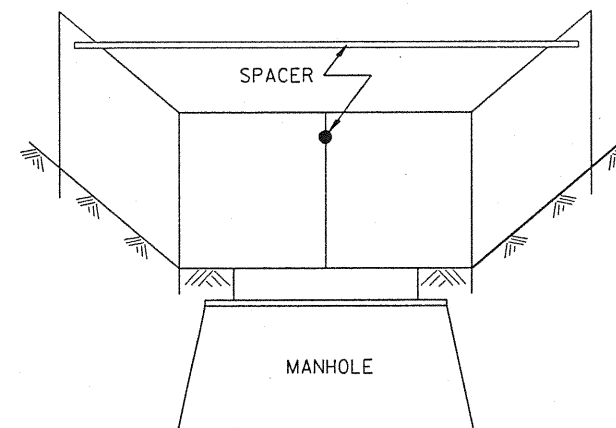
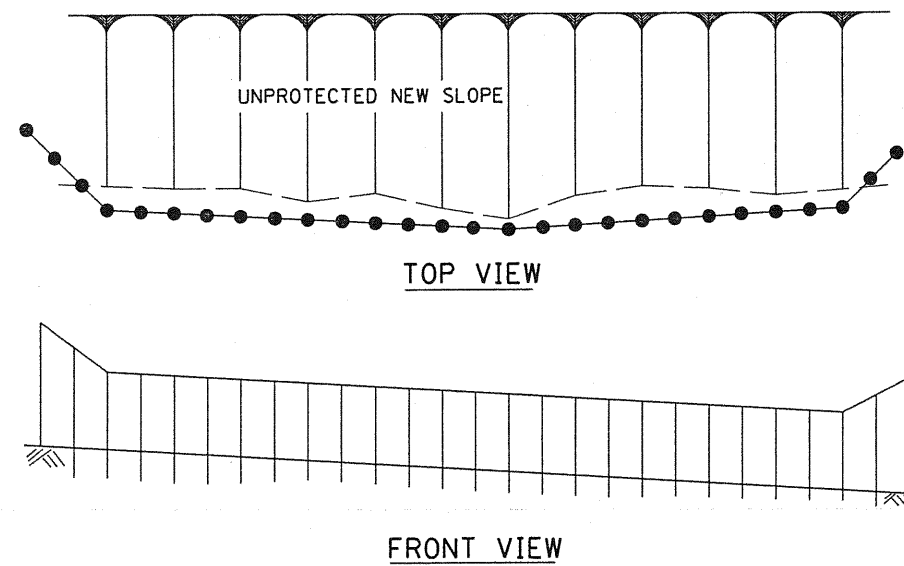
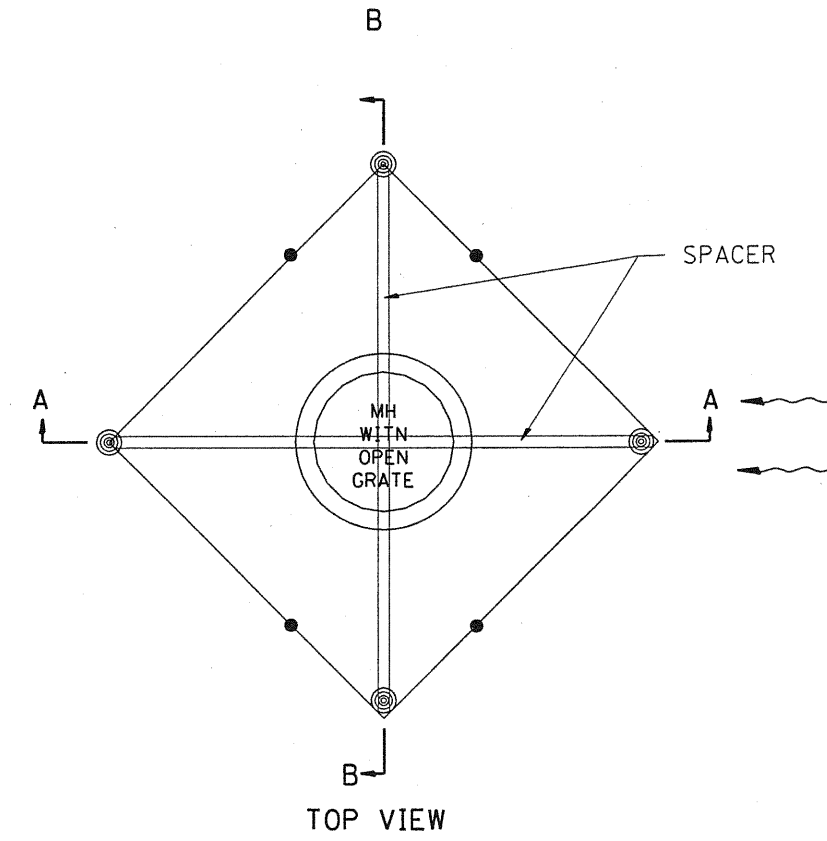
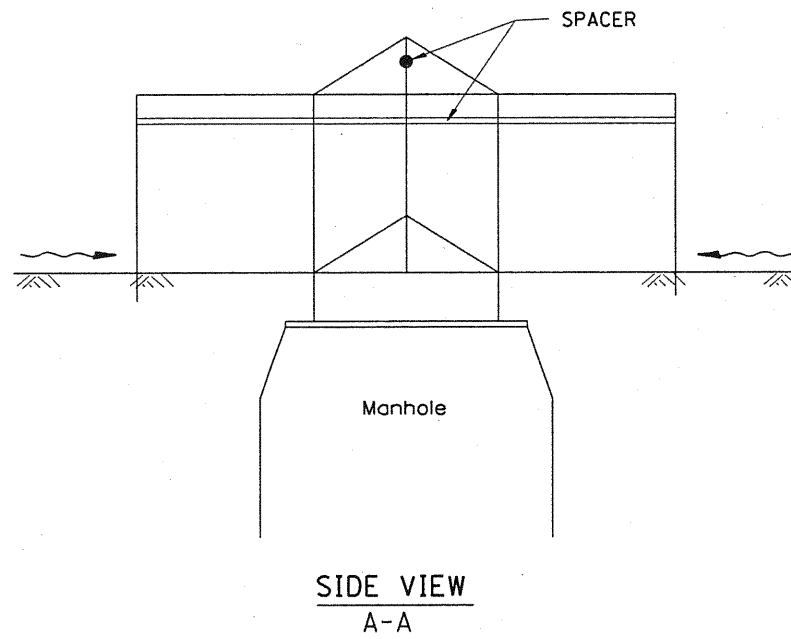
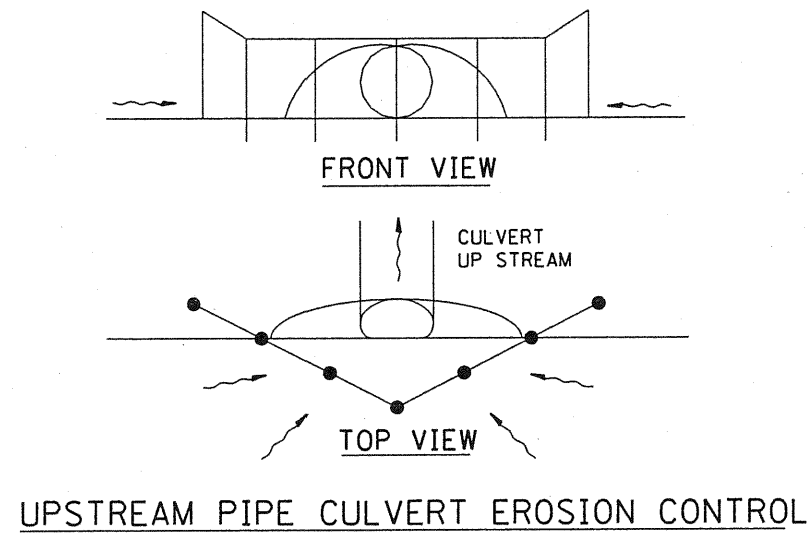

EROSION CONTROL
 AT
 OPEN GRATE MAN HOLE

GENERAL NOTES:

1. This work shall be performed in accordance with Sections 280 & 1081, of the Standard Specifications.
2. Additional Timber or Metal Post shall be installed, as needed.

All dimensions are in inches (millimeters) unless otherwise noted.

1-1-97		T.P.	
3-11-03	ELIMINATED SILT FENCE DITCH CHECK	M.A.	

STATE OF ILLINOIS
 DEPARTMENT OF TRANSPORTATION

TYPICAL APPLICATION OF SILT FILTER FENCE

NOT TO SCALE

CADD STD. 280001-D4

F.A.P. RTE.	SECTION	COUNTY	TOTAL SHEETS	SHEET NO.
310	(28B)BR-1	WARREN	71	58
CONTRACT NO. 68661				
FED. ROAD DIST. NO.		ILLINOIS FED. AID PROJECT		