

EXISTING TYPICAL CROSS SECTION 10

OFF RAMPS CB AND DA

	STATION	TO	STATION
CB	10+00.00		28+63.98
DA	10+00.00		27+60.49

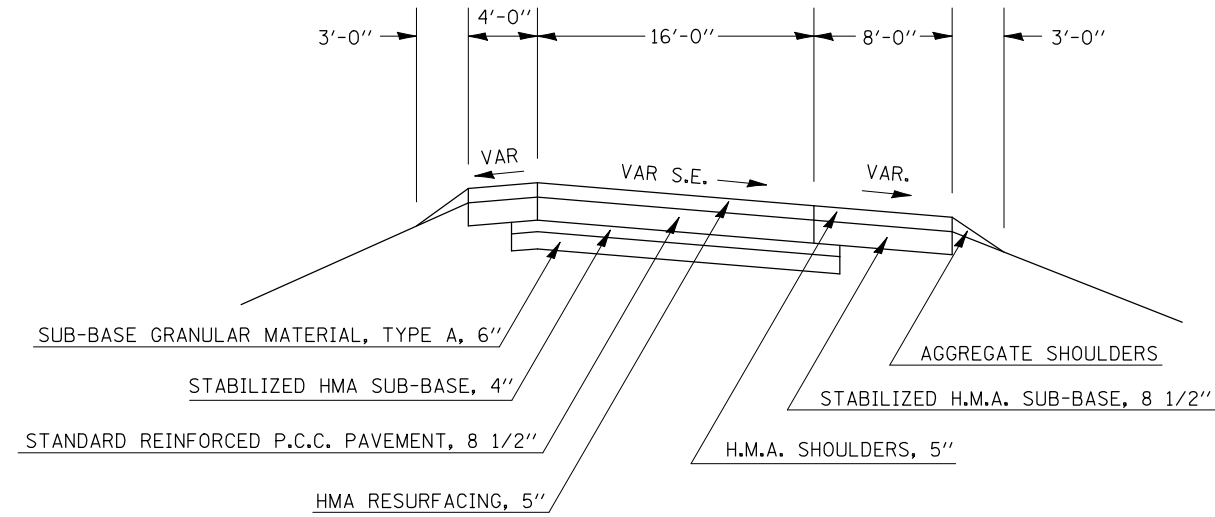

EXISTING TYPICAL CROSS SECTION 11

ON RAMPS AC AND BD

	STATION	TO	STATION
AC	10+24.00		31+64.13
BD	10+24.00		32+79.31

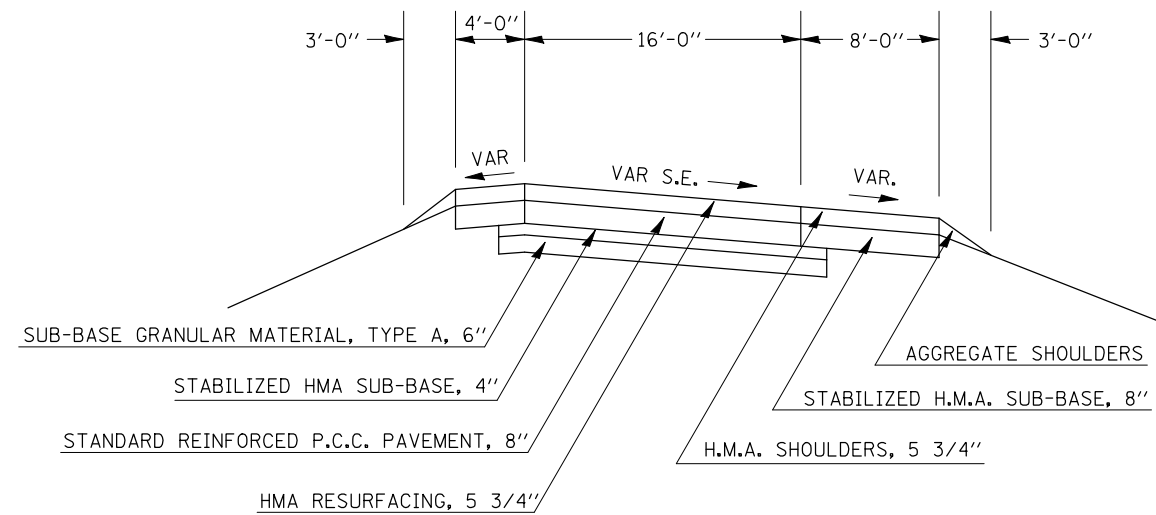

FILE NAME =	USER NAME = hoganbj	DESIGNED -	REVISED - BJH 8/10/2010
ct:\pwork\pwork\hoganbj\d0158340\0570650-sh-typical.dgn		DRAWN -	REVISED -
		CHECKED -	REVISED -
		DATE -	REVISED -

**STATE OF ILLINOIS
DEPARTMENT OF TRANSPORTATION**

EXISTING TYPICAL SECTIONS

SCALE: SHEET NO. OF SHEETS STA. TO STA.

F.A.I. RTE.	SECTION	COUNTY	TOTAL SHEETS	SHEET NO.
74	(57-20(1),21,22)RS-3	MCLEAN	150	19
CONTRACT NO. 70550				
ILLINOIS FED. AID PROJECT				