

TYPICAL STAGING DETAILS @ PROPOSED S.N. 074-8315 STAGE I

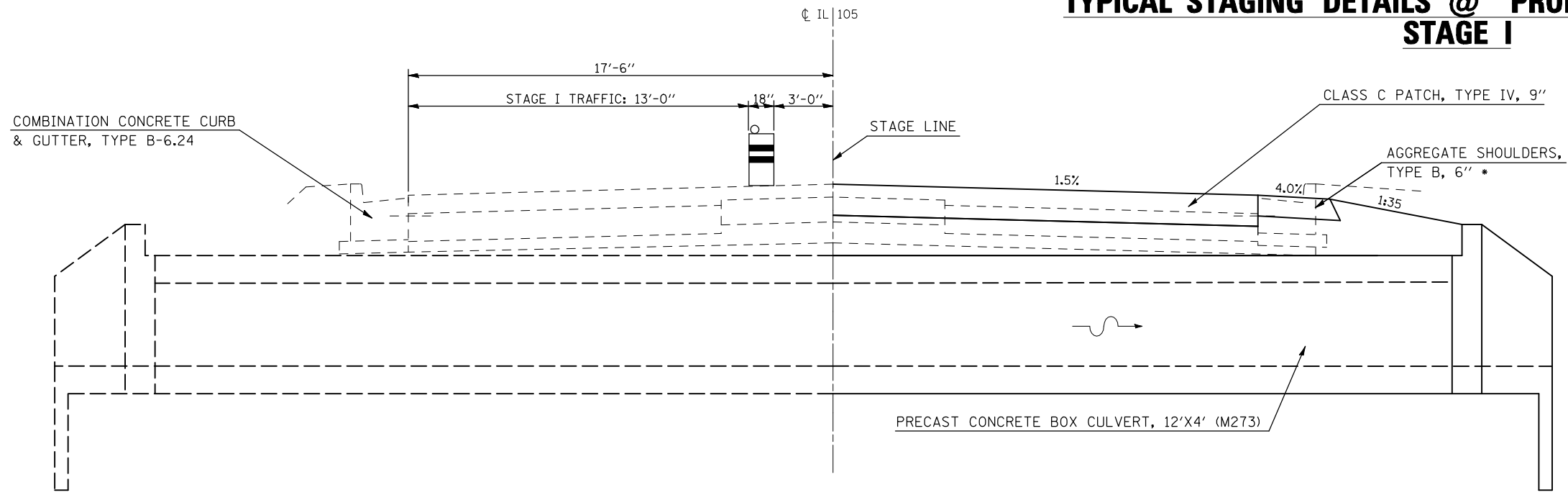

TYPICAL STAGING DETAILS @ PROPOSED S.N. 074-8315 STAGE II

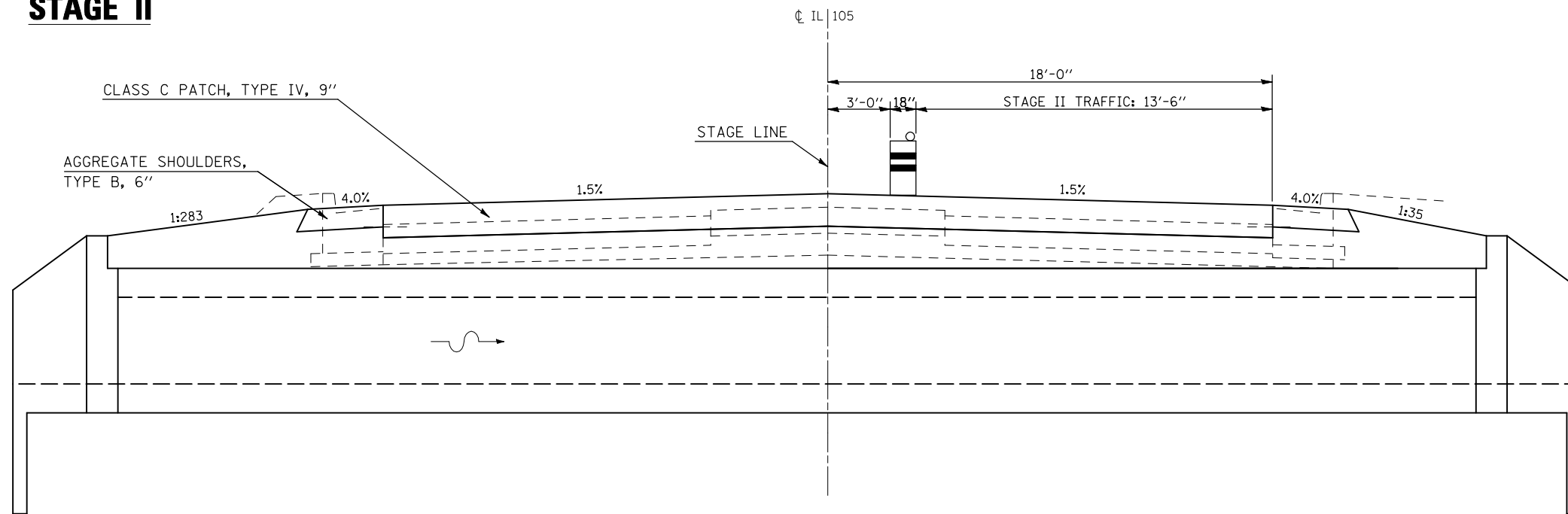

GENERAL NOTES

1. Refer to Special Provisions for TRAFFIC CONTROL AND PROTECTION, STANDARD 701201 and STAGE CONSTRUCTED ACROSS ROAD STRUCTURES for additional information.
2. The Engineer may reduce or eliminate lengths or locations of AGGREGATE SHOULDERS, TYPE B, 6" and EARTH EXCAVATION based on field conditions.
3. Construct downstream end of A.R. culvert first.
4. AGGREGATE SHOULDERS, TYPE B, 6" for Stage I may be completed at any time prior to Stage I. AGGREGATE SHOULDERS, TYPE B, 6" for Stage II should not be completed until the half-width culvert from Stage I has been constructed.
- 5. Replace previously constructed AGGREGATE SHOULDERS, TYPE B, 6" as needed when construction is completed.
- 6. Extra Quantities for AGGREGATE SHOULDERS, TYPE B are included in the plans, if needed, to build up the existing shoulder for STAGE I TRAFFIC.

A.R. CULVERT LOCATION	TRAFFIC CONTROL STANDARD	ESTIMATED TIME
STA. 271+22.00	701201	24 HRS (2) - 12 HR DAY SHIFTS

FILE NAME =	USER NAME = hennessdm	DESIGNED -	REVISED -
ct:\pw\work\p\dot\hennessdm\0184799\0570800-sh1-staging.dgn		DRAWN -	REVISED -
	PLOT SCALE = 40.0000' / IN.	CHECKED -	REVISED -
	PLOT DATE = 10/19/2010	DATE -	REVISED -

**STATE OF ILLINOIS
DEPARTMENT OF TRANSPORTATION**

TYPICAL STAGING DETAILS

SCALE: SHEET NO. 3 OF 4 SHEETS STA. TO STA.

F.A.P. RTE.	SECTION	COUNTY	TOTAL SHEETS	SHEET NO.
741	(8,9,10)CR	PIATT	65	34
CONTRACT NO. 70800				
ILLINOIS FED. AID PROJECT				