

THRIE BEAM END SHOE DETAIL

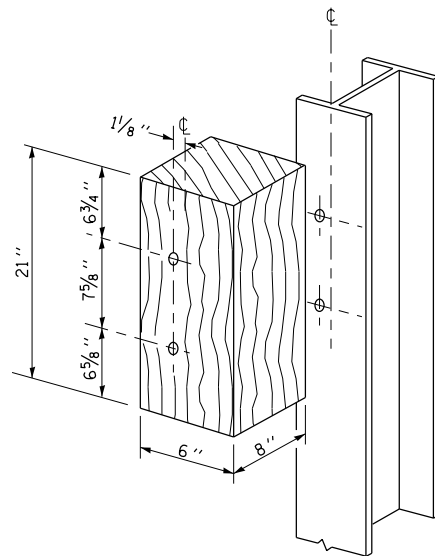

POSTS 1-11 WOOD BLOCKOUT DETAIL

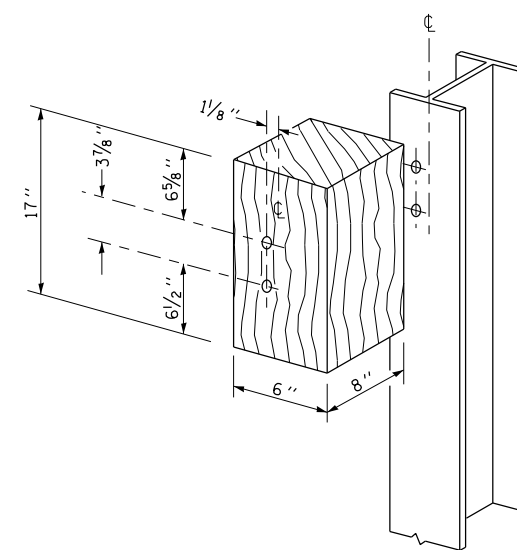

POST 12 WOOD BLOCKOUT DETAIL

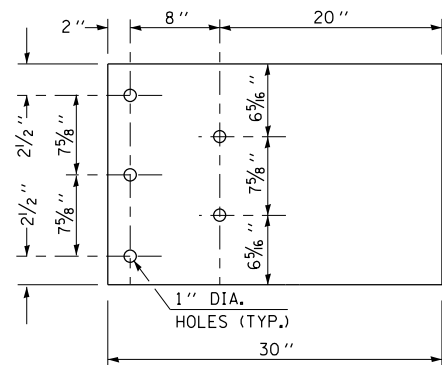

PARAPET WOOD BLOCK-OUT DETAIL

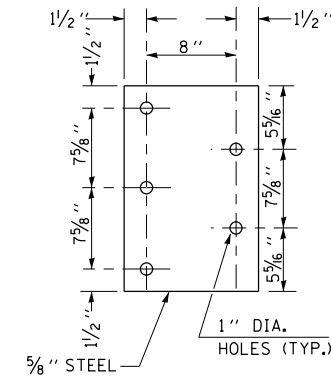
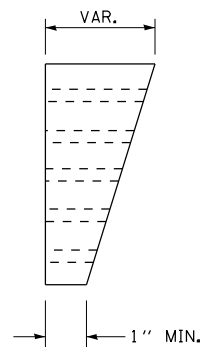

PARAPET STEEL BEARING PLATE DETAIL

(5 EACH INDIVIDUAL 5"X5"X5/8" STEEL PLATES WITH CENTERED 1" HOLES MAY BE SUBSTITUTED FOR THE PLATE SHOWN.)

FILE NAME =	USER NAME = laughlinc1	DESIGNED -	REVISED -
et:\pw\work\p\dot\laughlinc1\0230976\8077DET02.SHT		DRAWN -	REVISED -
	PLOT SCALE = 20.000' / in.	CHECKED -	REVISED -
	PLOT DATE = Aug-11-2010 10:38:59AM	DATE -	REVISED -

**STATE OF ILLINOIS
DEPARTMENT OF TRANSPORTATION**

**TRAFFIC BARRIER
TERMINAL, TYPE 6 (SPECIAL)**

SCALE: SHEET NO. 0F 2 SHEETS STA. TO STA.

F.A.P. RTE.	SECTION	COUNTY	TOTAL SHEETS	SHEET NO.
506	123 B-1	HANCOCK	70	26
CONTRACT NO. 72992				
FED. ROAD DIST. NO. ILLINOIS FED. AID PROJECT				