

STATE OF ILLINOIS
DEPARTMENT OF TRANSPORTATION

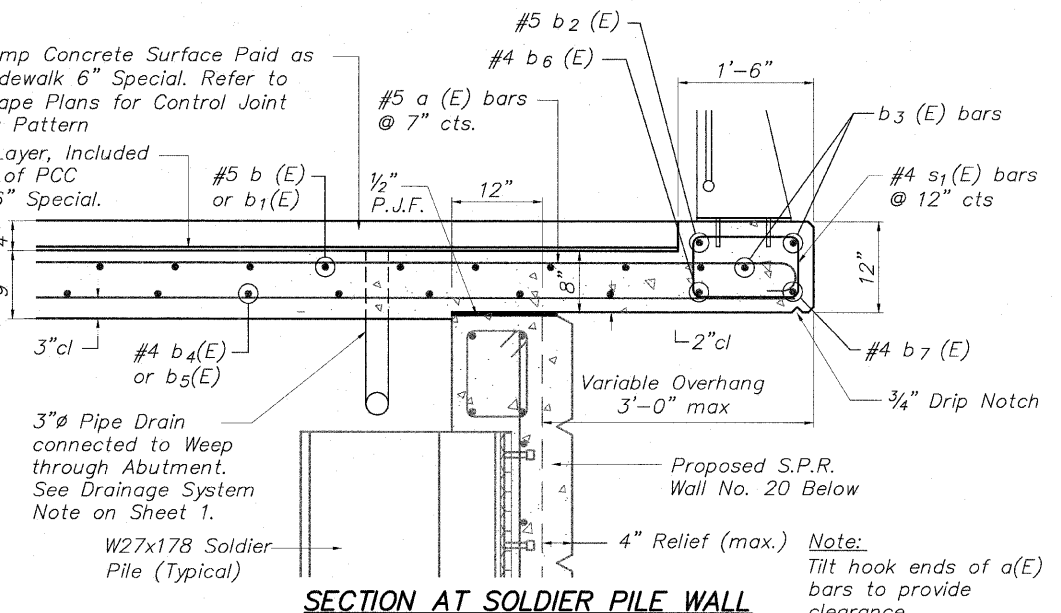
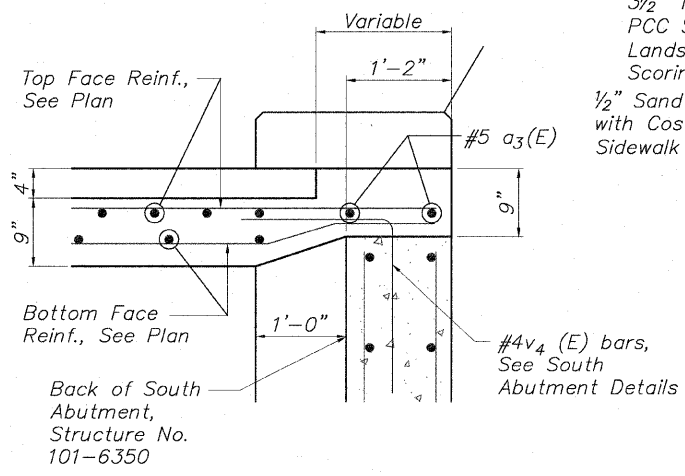
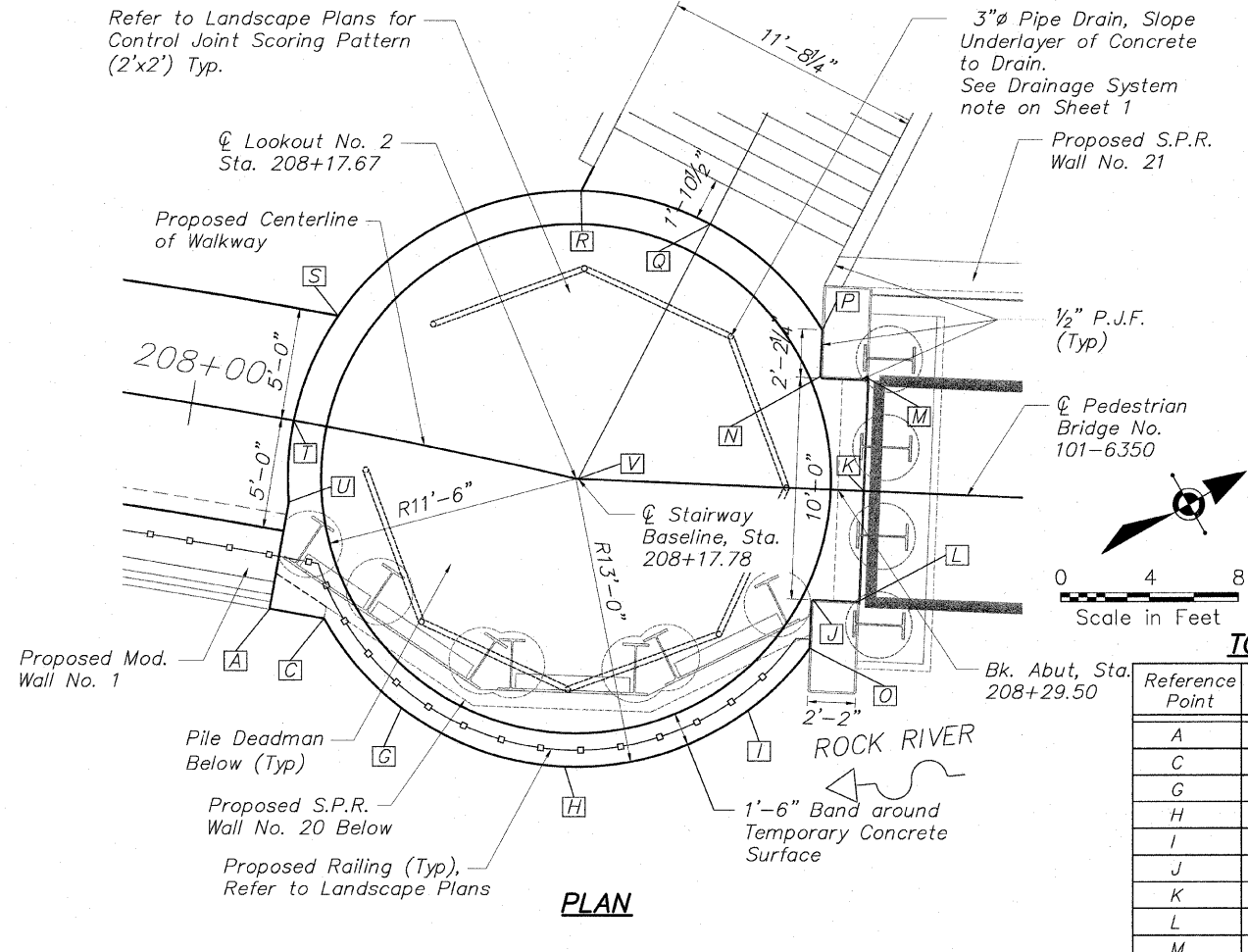

SECTION AT BRIDGE ABUTMENT
TOP OF SLAB ELEVATION CHART

Reference Point	Station to Top of Slab Elevation Pt.	Offset to Top of Slab Elevation Pt.	Elevation	Reference Point	Station to Top of Slab Elevation Pt.	Offset to Top of Slab Elevation Pt.	Elevation
A	208+05.12	8.56' Rt.	719.90	N	208+28.58	5.00' Lt.	719.87
C	208+07.71	8.54' Rt.	719.90	O	208+28.50	7.19' Rt.	719.74
G	208+13.21	12.25' Rt.	719.86	P	208+28.58	7.19' Lt.	719.92
H	208+17.67	13.00' Rt.	719.81	Q	208+23.14	11.74' Lt.	720.13
I	208+23.71	11.52' Rt.	719.71	R	208+15.08	12.73' Lt.	720.13
J	208+28.58	5.00' Rt.	719.76	S	208+05.79	5.00' Lt.	720.10
K	208+30.67	0.00' Rt.	719.84	T	208+04.67	0.00' Lt.	720.01
L	208+30.59	5.00' Rt.	719.79	U	208+05.11	3.67' Rt.	719.93
M	208+30.59	5.00' Lt.	719.89	V	208+17.67	0.00' Rt.	719.94

BILL OF MATERIAL

LOOKOUT No. 2 SLAB

Bar	No.	Size	Length	Shape
a (E)	38	#5	14'-7"	—
a ₁ (E)	11	#5	14'-0"	—
a ₂ (E)	9	#5	10'-8"	—
a ₃ (E)	2	#5	9'-8"	—
a ₄ (E)	26	#4	13'-8"	—
a ₅ (E)	19	#4	11'-7"	—
a ₆ (E)	2	#5	11'-9"	—
b (E)	42	#5	14'-0"	—
b ₁ (E)	14	#5	10'-8"	—
b ₂ (E)	3	#5	24'-0"	R11'-8"
b ₃ (E)	6	#5	23'-3"	R12'-9"
b ₄ (E)	34	#4	13'-8"	—
b ₅ (E)	12	#4	10'-3"	—
b ₆ (E)	3	#4	23'-8"	R11'-8"
b ₇ (E)	3	#4	23'-0"	R12'-9"
s ₁ (E)	66	#4	4'-5"	□

Concrete Structures	Cu. Yd.	16.1
Reinforcement Bars (Epoxy Coated)	Pound	2,938
Rubbed Finish	Sq. Ft.	26

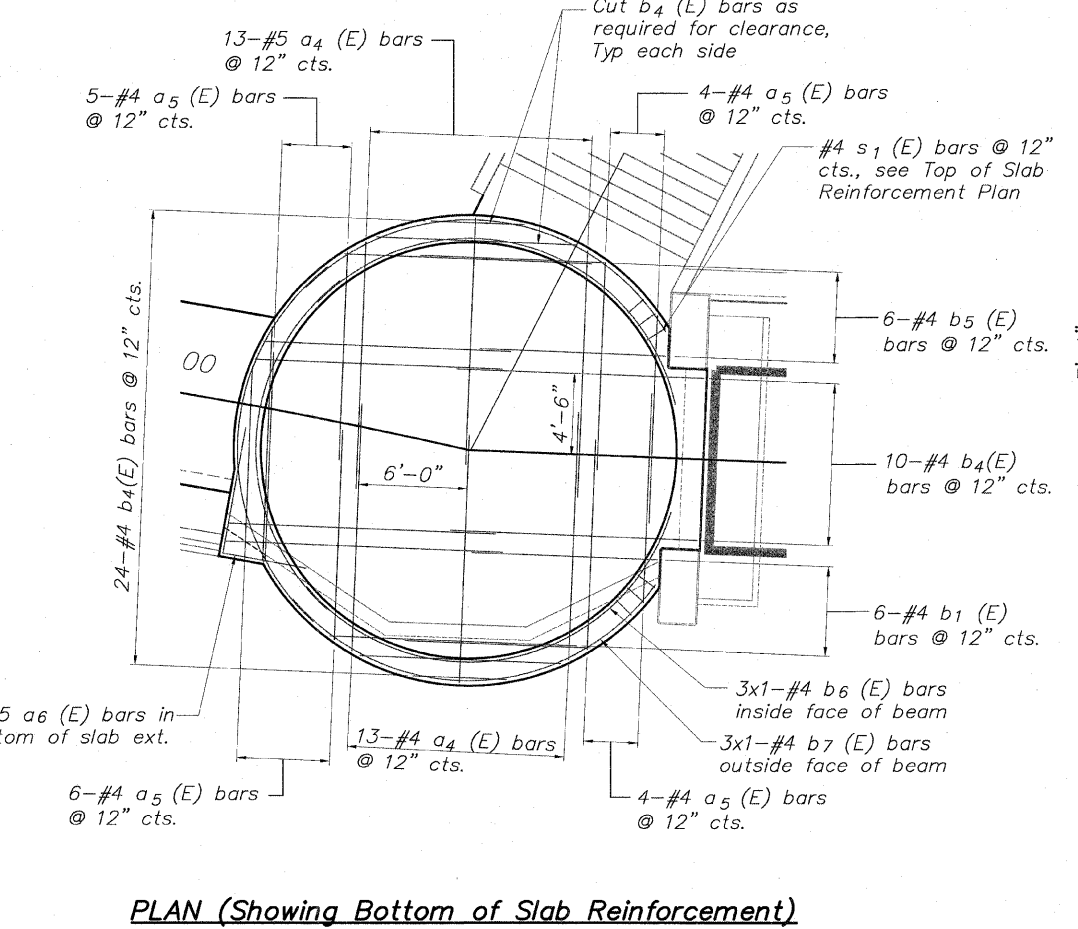
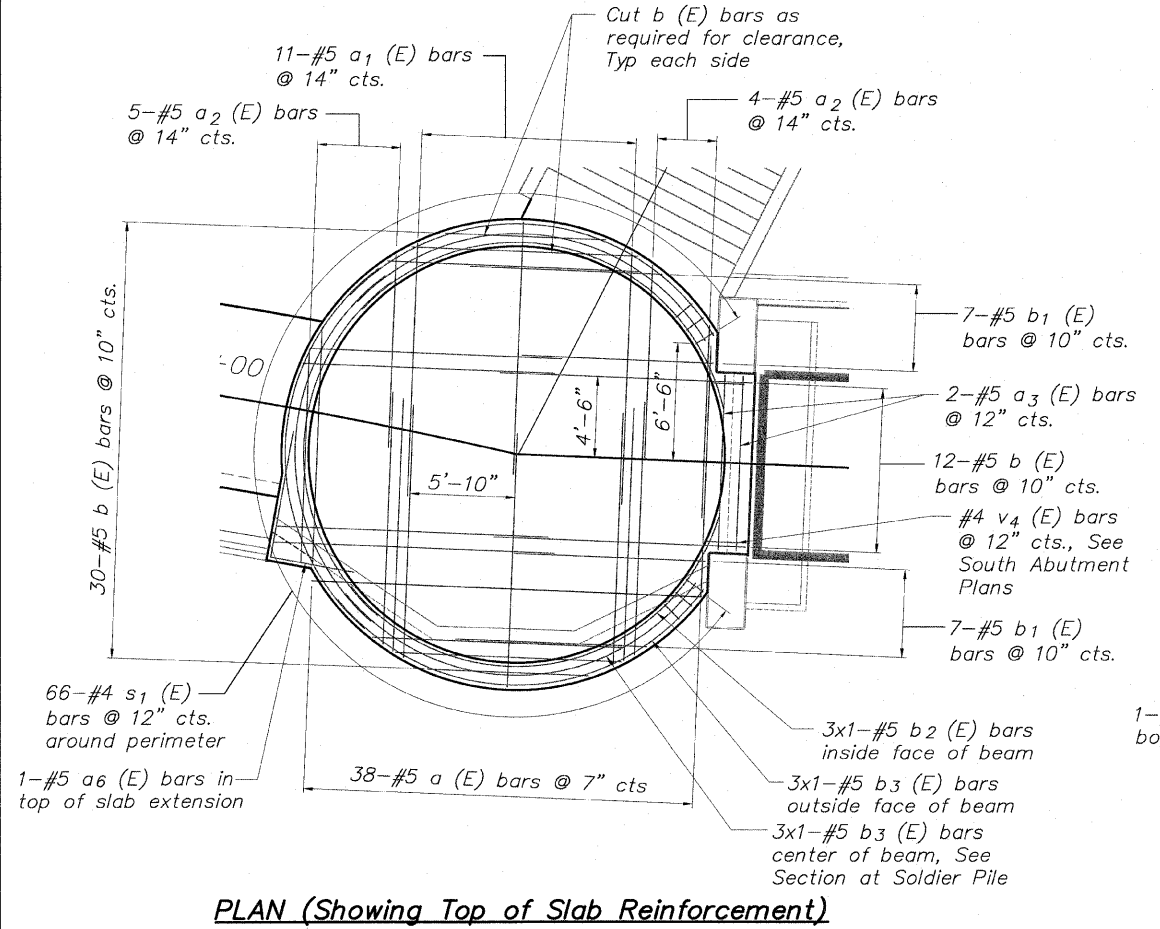

BAR a₆(E)

BAR s₁(E)

BAR a (E)
SLAB DETAILS LOOKOUT No. 2
PEDESTRIAN RIVERWALK
ALONG THE ROCK RIVER
WINNEBAGO COUNTY
SECTION NO. 06-00543-00-BT
STATION 208+17.67

DESIGNED	CTB
CHECKED	AAG
DRAWN	JAW
CHECKED	JMH

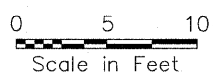

McClure
Engineering Associates, Inc.
7282 Argue Drive
(815) 398-2332
Rockford, Illinois 61107-5837
Fax (815) 398-2496
Design Firm License: Illinois #184-000816
Copyright 2010 By McClure Engineering Associates, Inc.

SHEET NO. 5
5 SHEETS

F.A. RTE.	SECTION	COUNTY	TOTAL SHEETS	SHEET NO.
	06-00543-00-BT	WINNEBAGO	148	84
FED. ROAD DIST. NO.		ILLINOIS	FED. AID PROJECT	
		CONTRACT NO.		85521

H:\08-08 RIVERWALK MUSEUM\DESIGN\DRAWINGS\STRUCTURAL\08-08 LOOKOUT DET.DWG, PLANDDET LOOKOUT, 10/26/2010 3:53:19 PM, 11, JMH