

**EAST SLOPE PROTECTION PLAN**

▨ Slope Wall Removal = 72 s.f.

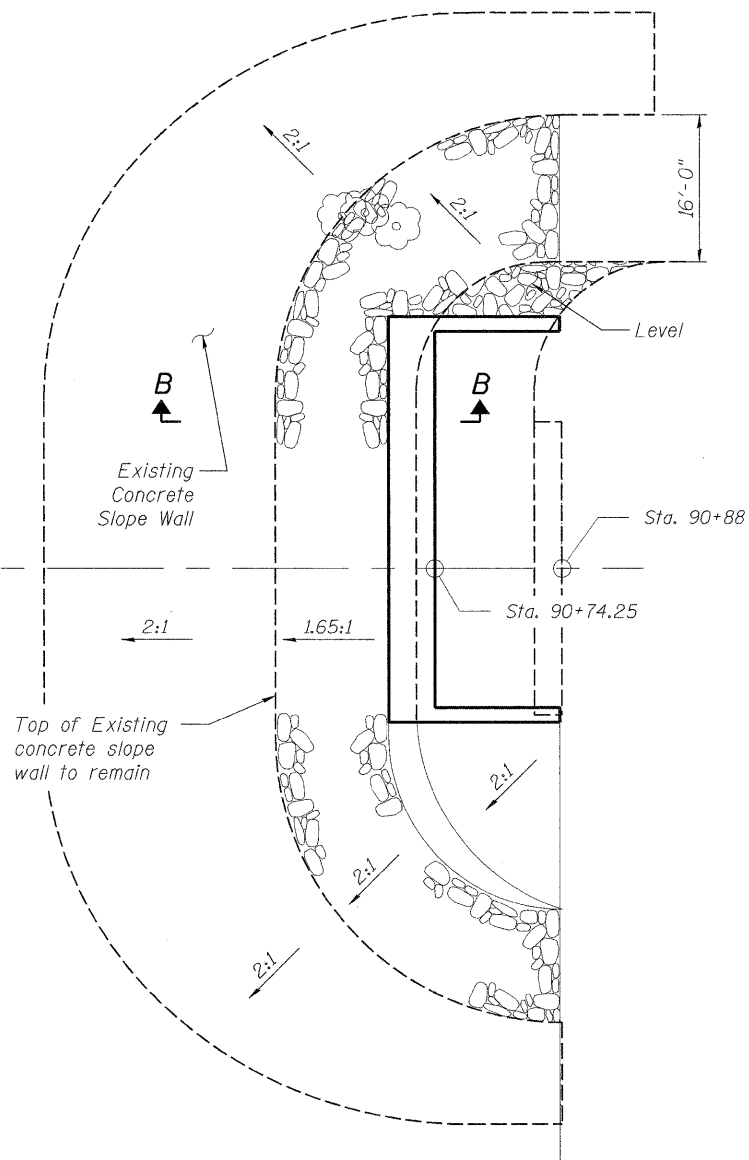

**WEST SLOPE PROTECTION PLAN**

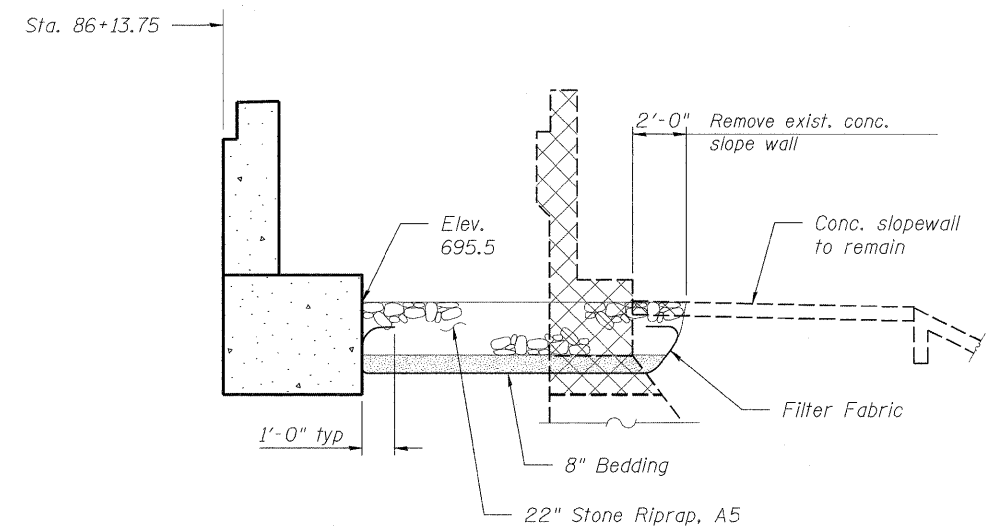

**SECTION A-A**

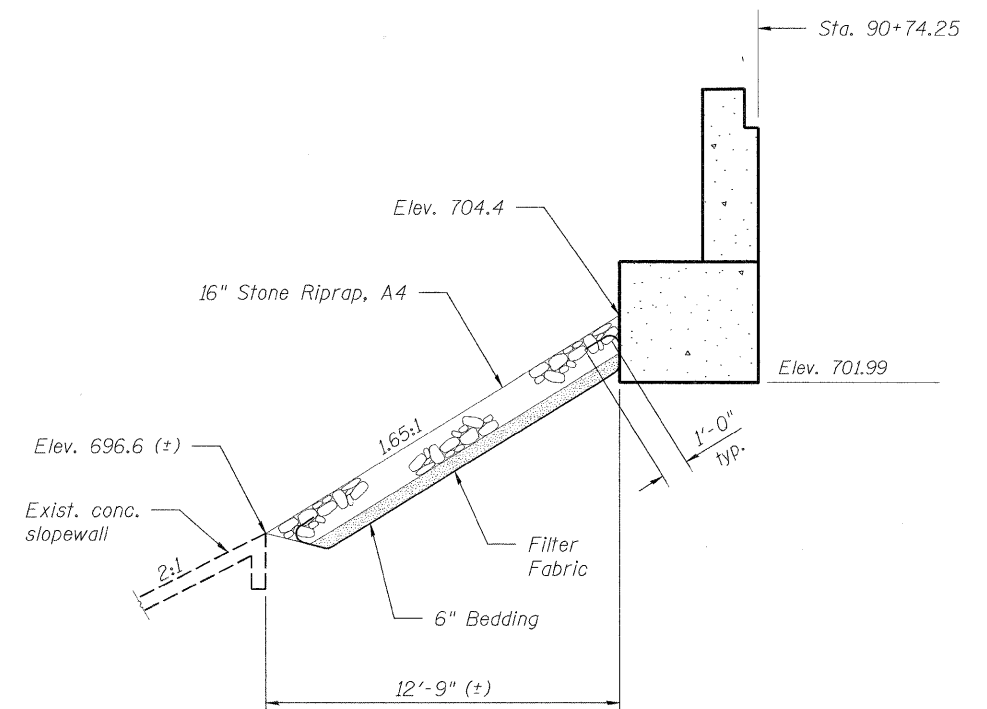

**SECTION B-B**

**SLOPE PROTECTION DETAILS  
STRUCTURE NUMBER 101-3100**

PROFESSIONAL DESIGN FIRM LICENSE #184-001084

© Copyright Hanson Professional Services Inc. 2010



Hanson Professional Services Inc.

JOB NO. 03R1807

DATE 10/26/10

SHEET NO. 3

47 SHEETS

|                           |                        |                  |                    |              |
|---------------------------|------------------------|------------------|--------------------|--------------|
| F.A.U. RTE. 5103          | SECTION 03-00337-00-BR | COUNTY Winnebago | TOTAL SHEETS 66    | SHEET NO. 18 |
| ILLINOIS FED. AID PROJECT |                        |                  | CONTRACT NO. 85523 |              |

10/26/2010  
 LAYOUT: JKR/SMA/08/23/10  
 DRAWN: MCM 10/25/10  
 REVIEWED: JKR/SMA/10/26/10  
 A:\03\03R1807\Struct\Sheet\03-SLOPE\_protect.dgn