

FOR INDEX OF SHEETS SEE SHEET 2

ROUTE	SECTION	COUNTY	TOTAL SHEETS	SHEET NUMBER
FAP 330	2009-133 I	COOK	28	1

**STATE OF ILLINOIS
DEPARTMENT OF TRANSPORTATION
DIVISION OF HIGHWAYS
DISTRICT ONE
PROPOSED HIGHWAY PLANS**

CONTRACT NO. 60H89

D-91-825-09

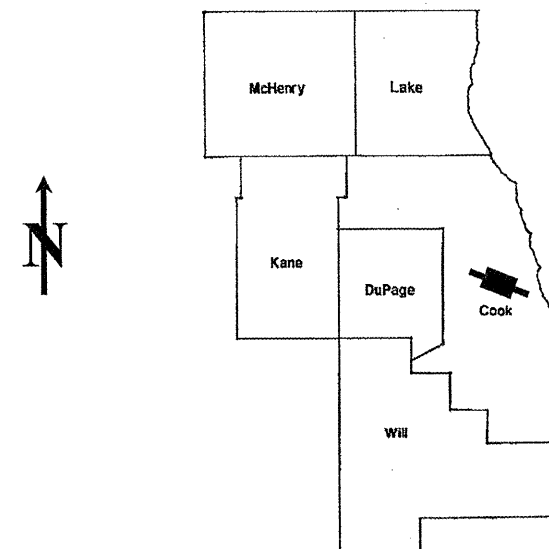

LOCATION OF IMPROVEMENT INDICATED THUS: 

**IMPROVEMENT IN THE VILLAGES
OF
HODGKINS AND WILLOW SPRINGS**

FAP 330: US 12/20/45/ (LAGRANGE RD.) NB
1) OVER DESPLAINES RIVER, SANTA FE DR & RR'S (SN 016-2467)
2) OVER S&S AND I&M CANALS & ICG RR (SN 016-2468)
SECTION 2009-133 I
JOINT REPAIR AND DECK PATCHING
COOK COUNTY
C-91-825-09

**LOCATION 1
SN: 016-2467**

TRAFFIC DATA:

LAGRANGE RD.
POSTED SPEED LIMIT = 45 MPH
2007 ADT = 78300

SANTA FE DR.
POSTED SPEED LIMIT = 25-35 MPH
2006 ADT = 6700

**LOCATION 2
SN: 016-2468**

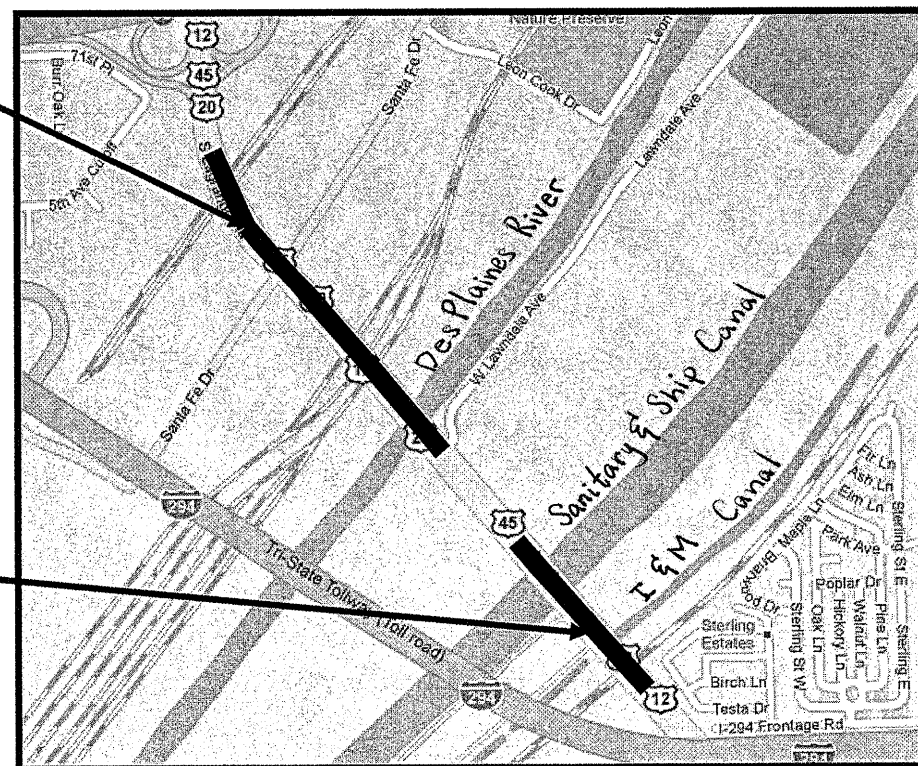

LYONS TOWNSHIP

PROJECT ENGINEER ROBERT BORO (847) 705-4178
PROJECT MANAGER KEN ENG

CONTRACT NO. 60H89

**STATE OF ILLINOIS
DEPARTMENT OF TRANSPORTATION
DIVISION OF HIGHWAYS**

SUBMITTED: APRIL 5, 2010
Diana M. O'Keefe
DEPUTY DIRECTOR OF HIGHWAYS, REGION ENGINEER

May 7 2010
Scott E. Stitt, P.E.
acting ENGINEER OF DESIGN AND ENVIRONMENT

May 7 2010
Christine M. Reed
DIRECTOR, DIVISION OF HIGHWAYS

**PRINTED BY THE AUTHORITY
OF THE STATE OF ILLINOIS**

J.U.L.I.E.: JOINT UTILITY LOCATION
INFORMATION FOR EXCAVATION
(800) 892-0123 OR 811

ROUTE	SECTION	COUNTY	TOTAL SHEETS	SHEET NUMBER
FAP 330	2009-133 I	COOK	28	2

CONTRACT 60H89

INDEX OF SHEETS

SHEET NO DESCRIPTION

1	COVER SHEET
2	INDEX OF SHEETS, STATE STANDARDS GENERAL NOTES
3 - 4	SUMMARY OF QUANTITIES
5	TRAFFIC STAGING
6 - 14	BRIDGE REPAIR PLANS (LOC. 1, SN 016-2467)
15 - 20	BRIDGE REPAIR PLANS (LOC. 2, SN 016-2468)
21 - 26	TRAFFIC CONTROL PLANS
27	DIST-1 TYPICAL PAVEMENT MARKING (TC13)
28	ARTERIAL ROAD INFORMATION SIGN (TC22)

LIST OF STATE STANDARDS

STANDARD NO DESCRIPTION

701301 - 03	LANE CLOSURE, 2L, 2W, SHORT TIME OPERATIONS
701601 - 06	URBAN LANE CLOSURE, MULTILANE, 1W OR 2W WITH NONTRAVERSIBLE MEDIAN
701901 - 01	TRAFFIC CONTROL DEVICES

GENERAL NOTES

BEFORE STARTING ANY EXCAVATION, THE CONTRACTOR SHALL CALL "J.U.L.I.E." AT (800) 892-0123 OR 811 FOR FIELD LOCATIONS OF BURIED ELECTRIC, TELEPHONE AND GAS UTILITIES. 48 HOUR NOTIFICATION IS REQUIRED.

THE CONTRACTOR SHALL COORDINATE CONSTRUCTION ACTIVITIES WITH UTILITY COMPANIES AND THE VILLAGES OF HODGKINS AND WILLOW SPRINGS

THE CONTRACTOR WILL NOT BE ALLOWED TO SET UP A YARD OR FIELD OFFICE ON STATE PROPERTY WITHOUT WRITTEN PERMISSION FROM THE DEPARTMENT.

THE CONTRACTOR SHALL CONTACT THE DISTRICT ONE TRAFFIC CONTROL SUPERVISOR AT (847)705-4470 A MINIMUM OF 72 HOURS IN ADVANCE OF BEGINNING WORK.

THE CONTRACTOR SHALL BE REQUIRED TO PROVIDE ACCESS TO ABUTTING PROPERTY AT ALL TIMES DURING THE CONSTRUCTION OF THIS PROJECT.

DO NOT SCALE PLANS FOR CONSTRUCTION DIMENSIONS.

PLAN DIMENSIONS AND DETAILS RELATIVE TO EXISTING PLANS ARE SUBJECT TO NOMINAL CONSTRUCTION VARIATIONS. THE CONTRACTOR SHALL FIELD VERIFY EXISTING DIMENSIONS AND DETAILS AFFECTING NEW CONSTRUCTION AND MAKE NECESSARY APPROVED ADJUSTMENTS PRIOR TO CONSTRUCTION OR ORDERING OF MATERIALS. SUCH VARIATIONS SHALL NOT BE CAUSE FOR ADDITIONAL COMPENSATION FOR A CHANGE IN SCOPE OF THE WORK, HOWEVER, THE CONTRACTOR WILL BE PAID FOR THE QUANTITY ACTUALLY FURNISHED BASED AT THE UNIT PRICE BID FOR THE WORK.

ILLINOIS DEPARTMENT OF
TRANSPORTATION

US 12/20/45 (LAGRANGE RD) (NB)
SN's 016-2467, 016-2468
INDEX OF SHEETS, STATE STANDARDS
GENERAL NOTES

ROUTE	SECTION	COUNTY	TOTAL SHEETS	SHEET NUMBER
FAP 330	2009-133 I	COOK	28	3

CONTRACT NO.: 60H89

SUMMARY OF QUANTITIES		CONSTRUCTION TYPE CODE: SFTY - 2A			
CODE NO.	ITEMS	UNITS	TOTAL QUANTITIES <i>URBAN</i> <i>100% MCHD</i>	SN 016-2467	SN 016-2468
50102400	CONCRETE REMOVAL	CU YD	62.2	47.1	15.1
50157300	PROTECTIVE SHIELD	SQ YD	1020	1020	
50300255	CONCRETE SUPERSTRUCTURE	CU YD	53.6	38.5	15.1
50300300	PROTECTIVE COAT	SQ YD	157.1	108.6	48.5
50800205	REINFORCEMENT BARS, EPOXY COATED	POUND	10,330	7420	2910
50800515	BAR SPLICERS	EACH	156	112	44
52000110	PREFORMED JOINT STRIP SEAL	FOOT	447	324	123
67000400	ENGINEER'S FIELD OFFICE, TYPE A	CAL MO	6	3	3
67100100	MOBILIZATION	L SUM	1	0.7	0.3
70101800	TRAFFIC CONTROL AND PROTECTION, (SPECIAL)	L SUM	1	0.5	0.5
70301000	WORK ZONE PAVEMENT MARKING REMOVAL	SQ FT	2092	1046	1046
70400100	TEMPORARY CONCRETE BARRIER	FOOT	525	375	150
70400200	RELOCATE TEMPORARY CONCRETE BARRIER	FOOT	525	375	150

ILLINOIS DEPARTMENT OF TRANSPORTATION
 US 12/20/45 (LAGRANGE RD)
 SN 016-2467
 SN 016-2468
 SUMMARY OF QUANTITIES

Rev.

ROUTE	SECTION	COUNTY	TOTAL SHEETS	SHEET NUMBER
FAP 330	2009-133 I	COOK	28	4

CONTRACT NO.: 60H89

SUMMARY OF QUANTITIES		CONSTRUCTION TYPE CODE: SFTY - 2A			
CODE NO.	ITEMS	UNITS	TOTAL QUANTITIES	SN 016-2467	SN 016-2468
* 78000200	THERMOPLASTIC PAVEMENT MARKING - LINE 4"	FOOT	432	216	216
78300100	PAVEMENT MARKING REMOVAL	SQ FT	144	72	72
X0322256	TEMPORARY INFORMATION SIGNING	SQ FT	51.4	25.7	25.7
X0325303	STRUCTURAL REPAIR OF CONCRETE (DEPTH GREATER THAN 5 INCHES)	SQ FT	5.3	5.3	
X0325775	WET REFLECTIVE TEMPORARY TAPE, TYPE III, 4 INCH	FOOT	6280	3140	3140
X0326874	SILICONE JOINT SEALER, 3"	FOOT	42	42	
Z0016200	DECK SLAB REPAIR (PARTIAL)	SQ YD	23	23	
Z0030250	IMPACT ATTENUATORS, TEMPORARY (NON-REDIRECTIVE), TEST LEVEL 3	EACH	7	5	2
Z0030350	IMPACT ATTENUATORS, RELOCATE (NON-REDIRECTIVE), TEST LEVEL 3	EACH	7	5	2
Z0048665	RAILROAD PROTECTIVE LIABILITY INSURANCE	L SUM	1	1	

* Specialty Items

ILLINOIS DEPARTMENT OF TRANSPORTATION
 US 12/20/45 (LAGRANGE RD)
 SN 016-2467
 SN 016-2468
 SUMMARY OF QUANTITIES

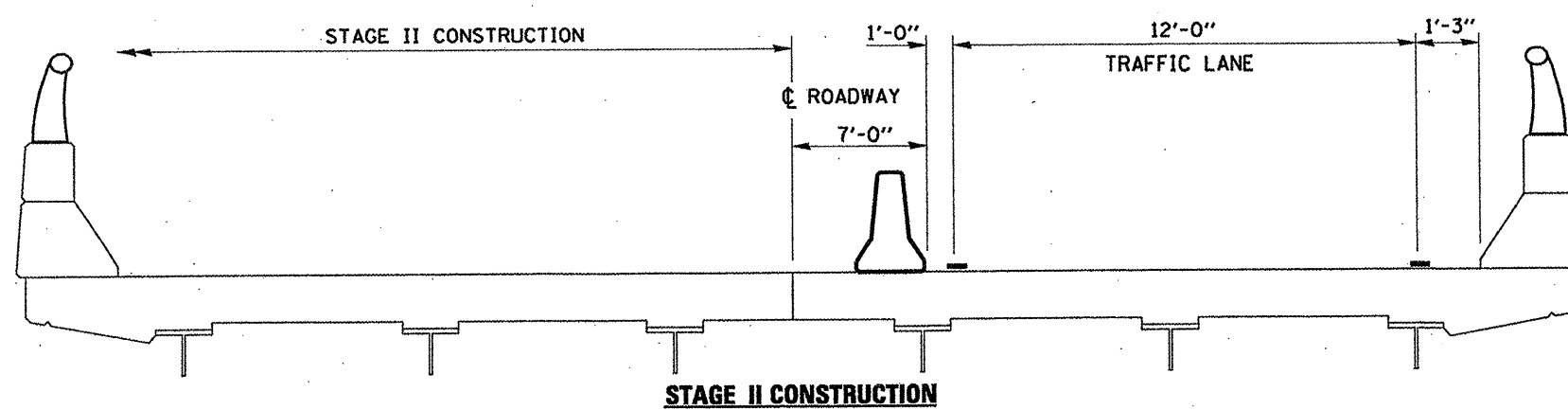
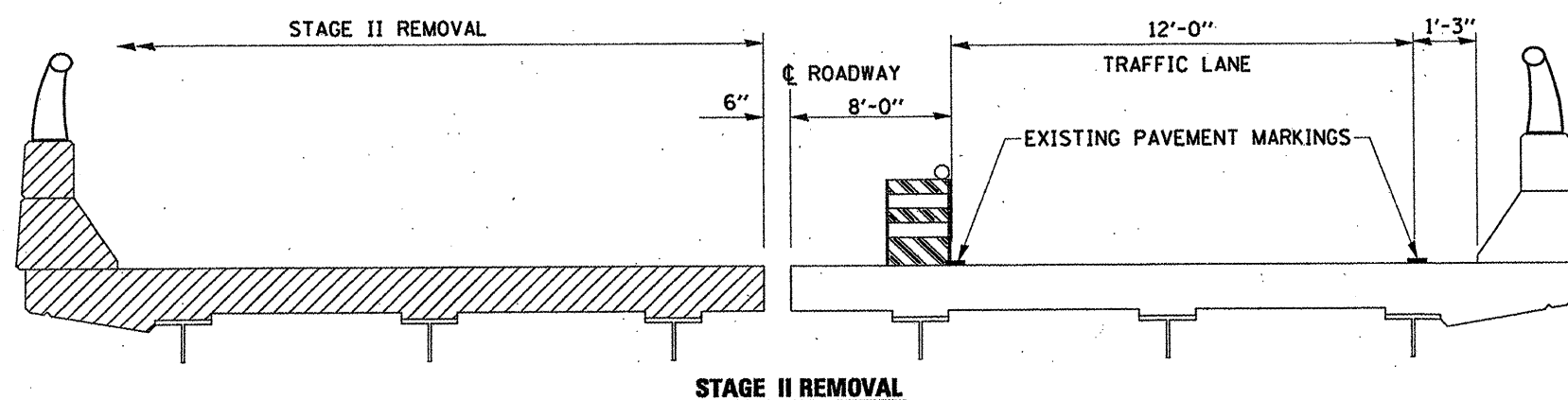
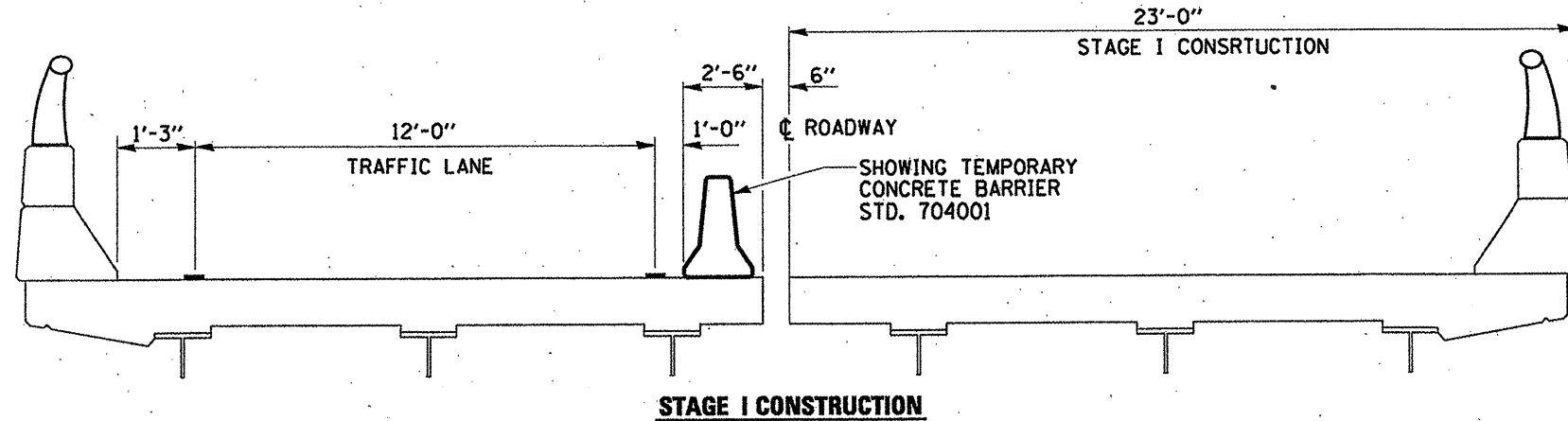
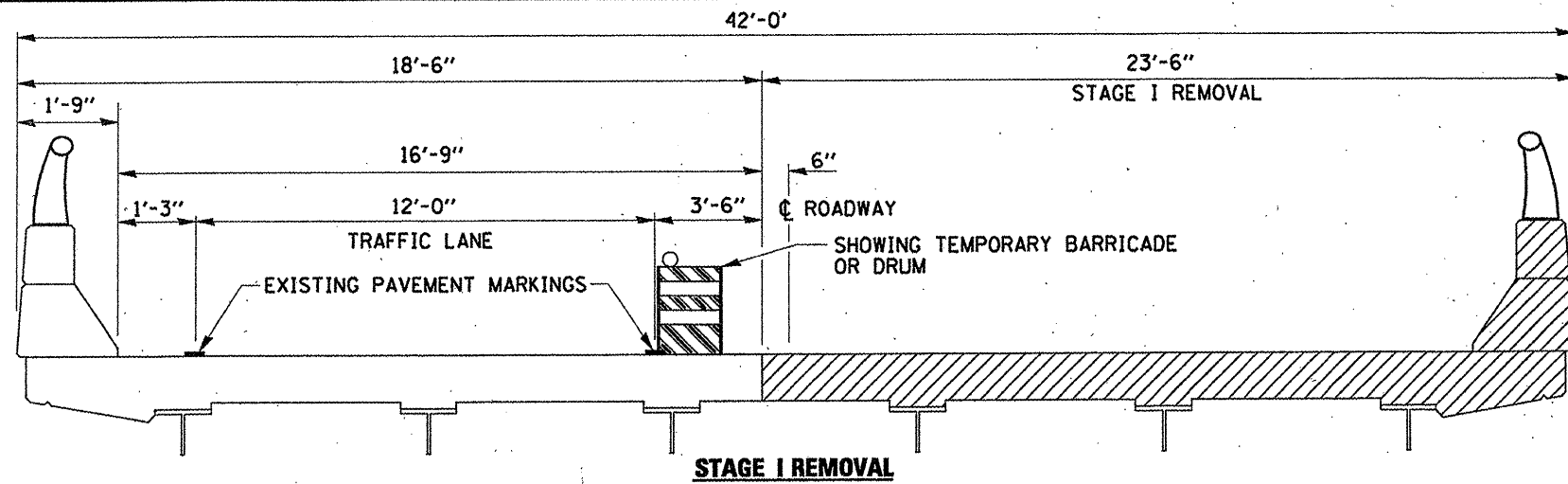

**CROSS SECTIONS
(LOOKING NORTH)**

FILE NAME =	USER NAME = ttniakosmv	DESIGNED -	REVISED -
ct:\p\work\p\pwidot\t\tinikosmv.d01671\09-0171.dgn		DRAWN -	REVISED -
PLOT SCALE = 100.0000 / IN.		CHECKED -	REVISED -
PLOT DATE = 4/28/2010		DATE -	REVISED -

**STATE OF ILLINOIS
DEPARTMENT OF TRANSPORTATION**

**US 122045 (LAGRANGE ROAD) NB
TRAFFIC STAGING
S.N. 016-2467 AND S.N. 016-2468**

SCALE: SHEET NO. OF SHEETS STA. TO STA.

F.A.P. RTE.	SECTION	COUNTY	TOTAL SHEETS	SHEET NO.
330	2009-133 I	COOK	28	5
CONTRACT NO. 60H89				
ILLINOIS FED. AID PROJECT				

STATE OF ILLINOIS
DEPARTMENT OF TRANSPORTATION

GENERAL NOTES

All structural steel shall conform to AASHTO Classification M-270 Gr. 36, unless otherwise noted.
Reinforcement bars shall conform to the requirements of ASTM A 706 Gr 60. See Special Provisions.
Reinforcement bars designated (E) shall be epoxy coated.
Prior to pouring the new concrete deck, all heavy or loose rust, loose mill scale, and other loose or potentially detrimental foreign material shall be removed from the surfaces in contact with concrete. Tightly adhered paint may remain unless otherwise noted. Removal shall be accomplished by methods that will not damage the steel and the cost will be included in the pay item covering removal of the existing concrete.
Plan dimensions and details relative to existing plans are subject to nominal construction variations. The Contractor shall field verify existing dimensions and details affecting new construction and make necessary approved adjustments prior to construction or ordering of materials. Such variations shall not be cause for additional compensation for a change in scope of the work, however, the Contractor will be paid for the quantity actually furnished at the unit price bid for the work.
Existing reinforcement bars extending into the removal area shall be cleaned, straightened and incorporated into the new construction. Any reinforcement bars that are damaged during concrete removal shall be replaced with an approved bar splicer or anchorage system. Cost included with Concrete Removal.
The deck surface shall have its final finish tined according to Article 420.09(e)(1) of the Standard Specifications. Cost included with Concrete Superstructures.
Joint openings shall be adjusted according to Article 520.04 of the Standard Specifications when the deck is poured at an ambient temperature other than 50° F.
The existing structural steel coating contains lead. The Contractor shall take appropriate precautions to deal with the presence of lead on this project.

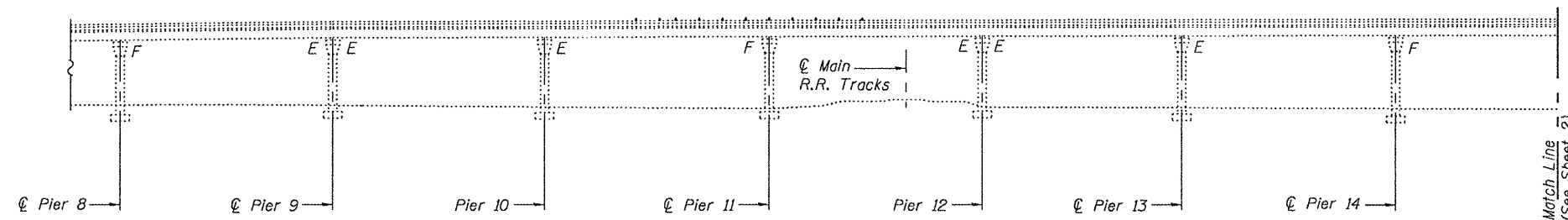
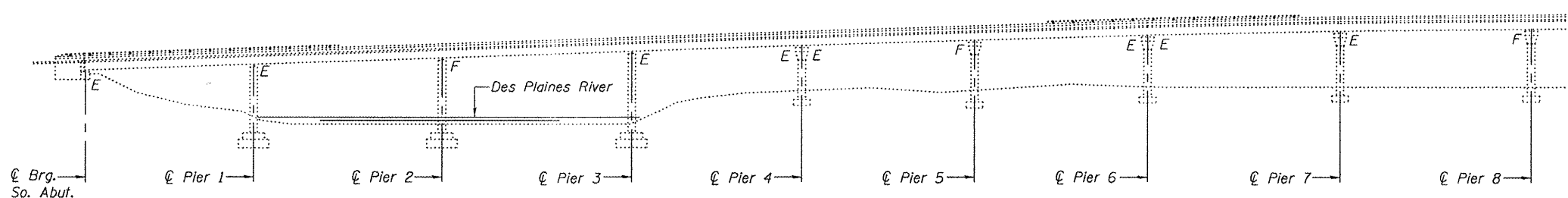

PARTIAL ELEVATION

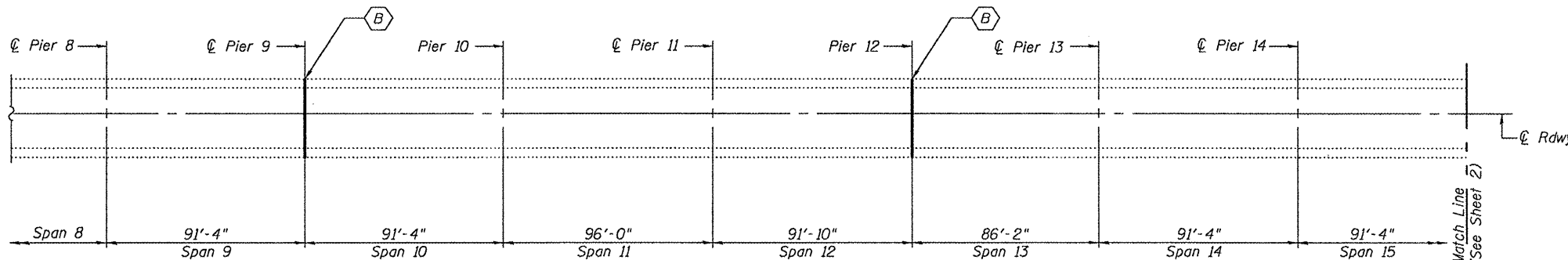
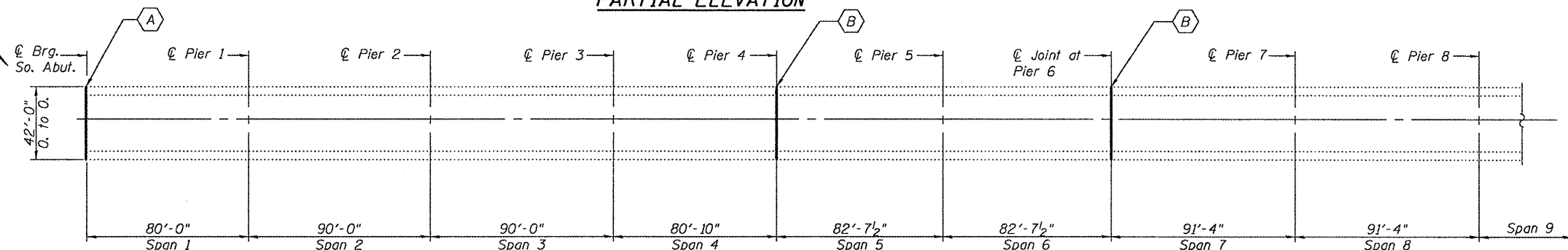

PARTIAL PLANS

- (A) Remove and Replace Silicone Joint Seal
- (B) Remove and Replace Joint with Strip Seal Joint
- (C) Remove and Replace Joint with shallow Strip Seal Joint

TOTAL BILL OF MATERIAL

ITEM	UNIT	QUANTITY
Concrete Removal	Cu. Yd.	47.1
Concrete Superstructure	Cu. Yd.	38.5
Preformed Joint Strip Seal	Foot	324
Reinforcement Bars, Epoxy Coated	Pounds	7,420
Bar Splicers	Each	112
Protective Coat	Sq. Yd.	108.6
Silicone Joint Sealer 3"	Foot	42

*New Concrete Only

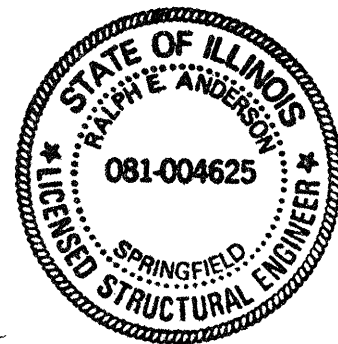

DESIGNED: *[Signature]* May 3, 2010
 CHECKED: *[Signature]* EXAMINED: *[Signature]*
 DRAWN: *[Signature]* PASSED: *[Signature]*
 CHECKED: *[Signature]*

Expires: November 30, 2010

PLAN AND ELEVATION
SN 016-2467

SHEET NO. 1 8 SHEETS	F.A.P. RTE. 330	SECTION 2009-1331	COUNTY Cook	TOTAL SHEETS 28	SHEET NO. 6
	FED. ROAD DIST. NO.		ILLINOIS	FED. AID PROJECT	
			CONTRACT NO. 60H89		

STATE OF ILLINOIS
DEPARTMENT OF TRANSPORTATION

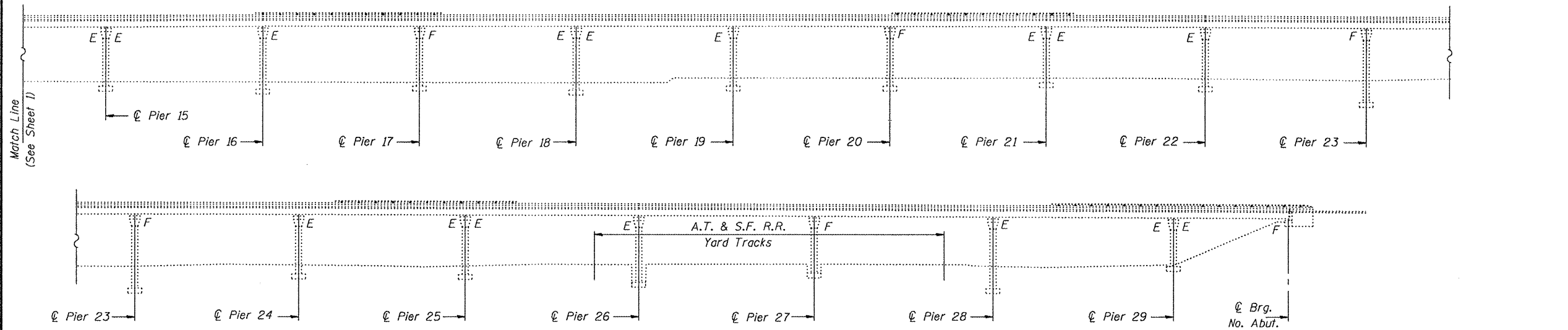

PARTIAL ELEVATION

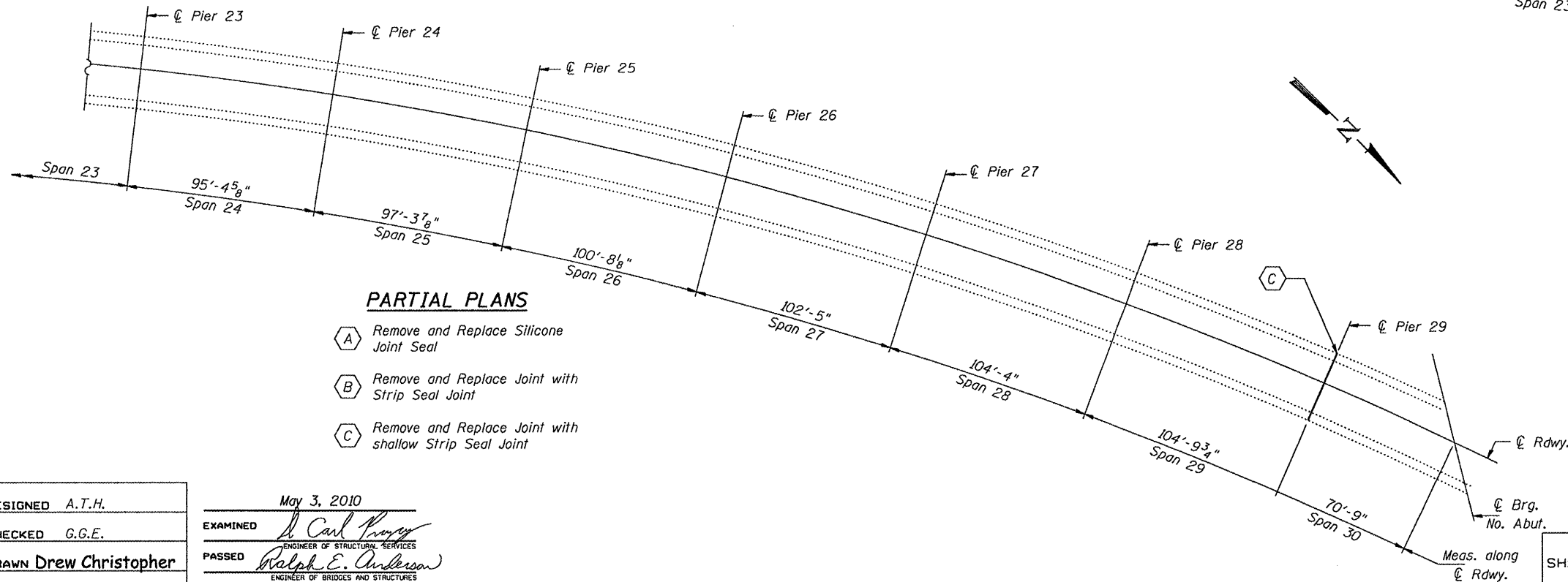
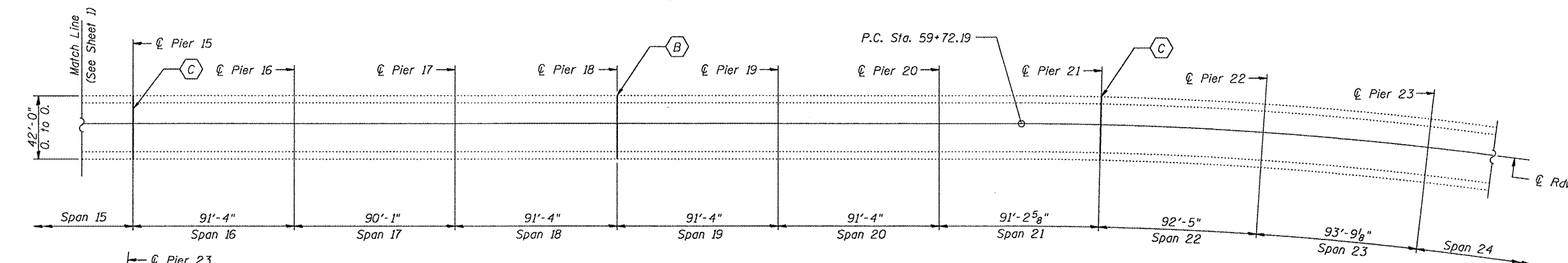

PARTIAL PLANS

- (A) Remove and Replace Silicone Joint Seal
- (B) Remove and Replace Joint with Strip Seal Joint
- (C) Remove and Replace Joint with shallow Strip Seal Joint

DESIGNED	A.T.H.
CHECKED	G.G.E.
DRAWN	Drew Christopher
CHECKED	A.T.H. G.G.E.

May 3, 2010

EXAMINED *Carl [Signature]*
ENGINEER OF STRUCTURAL SERVICES

PASSED *Ralph E. Anderson*
ENGINEER OF BRIDGES AND STRUCTURES

DETAILS
SN 016-2467

SHEET NO. 2 8 SHEETS	F.A.P. RTE. 330	SECTION 2009-1331	COUNTY Cook	TOTAL SHEETS 28	SHEET NO. 7
	CONTRACT NO. 60H89				
FED. ROAD DIST. NO.		ILLINOIS FED. AID PROJECT			

STATE OF ILLINOIS
DEPARTMENT OF TRANSPORTATION

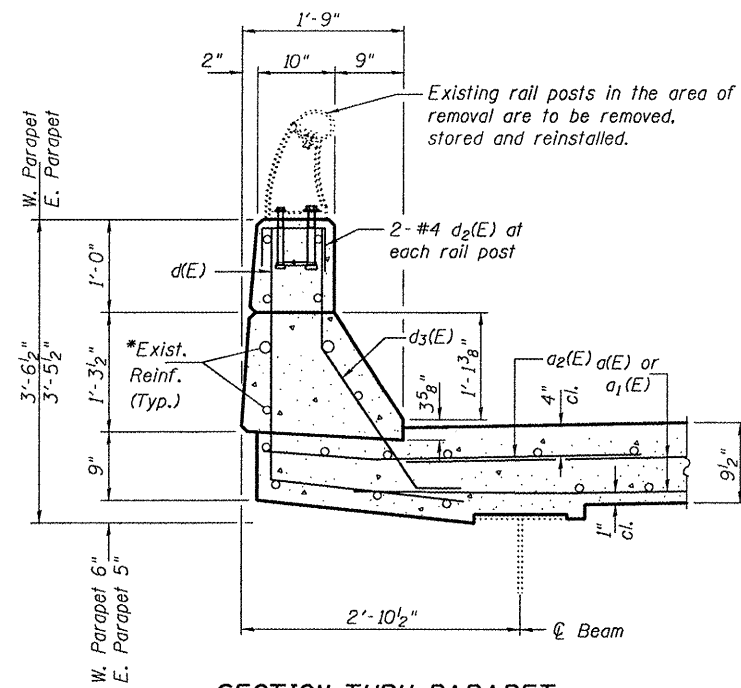

SECTION THRU PARAPET

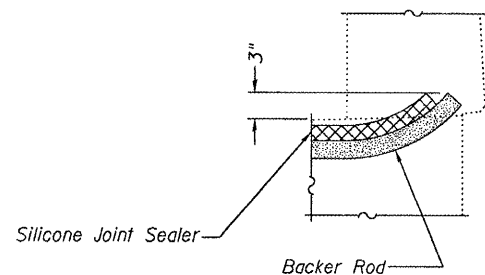

TYPICAL END TREATMENT AT SILICONE JOINT SEAL

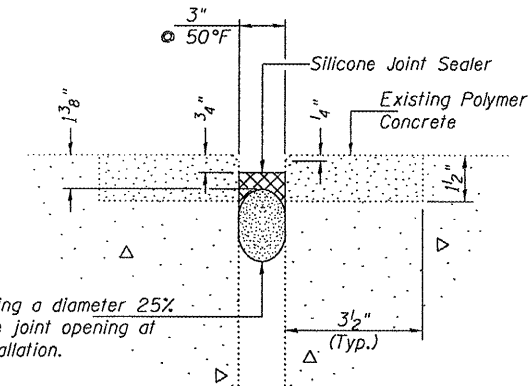

DETAIL A

SOUTH ABUTMENT JOINT REPAIR

Cost of removal of existing sealer is included with the cost of Silicone Joint Sealer

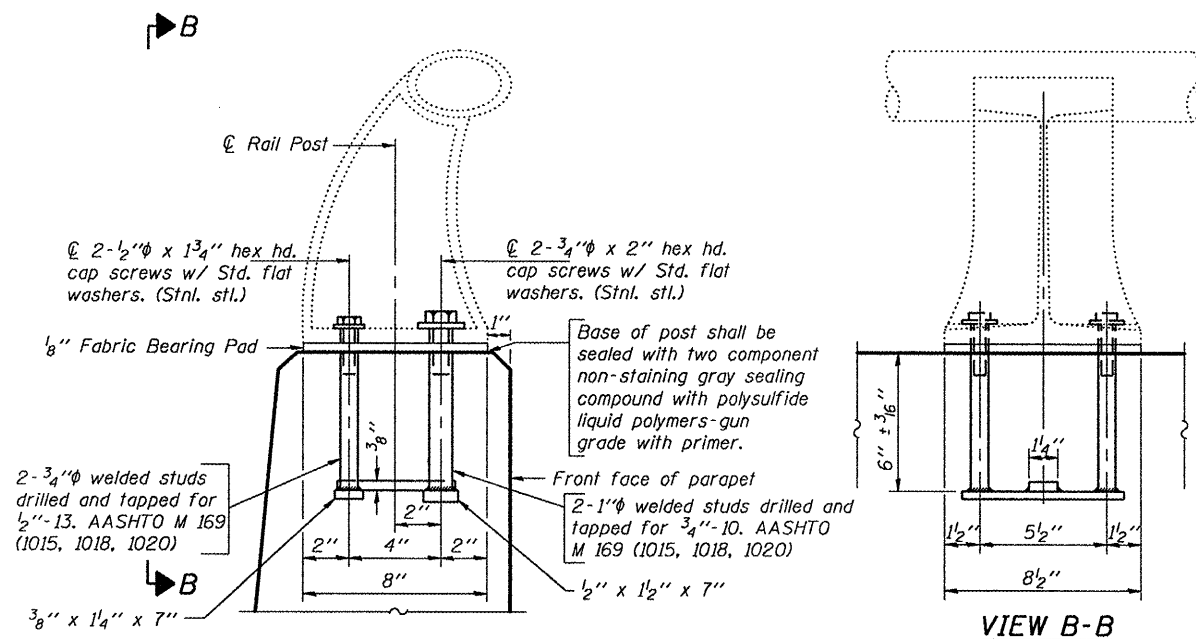

RAIL POST ANCHOR DETAIL

VIEW B-B

In lieu of the cast-in-place anchor device shown, the Contractor has the option of drilling and setting stainless steel anchor rods of the same diameter and grade as the specified cap screws according to Article 509.06 of the Standard Specifications. Embedment shall be according to the manufacturer's specifications.

RAIL POST NCHORAGE DETAIL

DESIGNED	A.T.H.
CHECKED	G.G.E.
DRAWN	Drew Christopher
CHECKED	A.T.H. G.G.E.

EXAMINED	May 3, 2010 <i>Carl Perry</i> ENGINEER OF STRUCTURAL SERVICES
PASSED	<i>Ralph E. Anderson</i> ENGINEER OF BRIDGES AND STRUCTURES

**DETAILS
SN 016-2467**

SHEET NO. 3	F.A.P. RTE.	SECTION	COUNTY	TOTAL SHEETS	SHEET NO.
	330			2009-1331	Cook
8 SHEETS	FED. ROAD DIST. NO.		ILLINOIS	FED. AID PROJECT	
			CONTRACT NO. 60H89		

STATE OF ILLINOIS
DEPARTMENT OF TRANSPORTATION

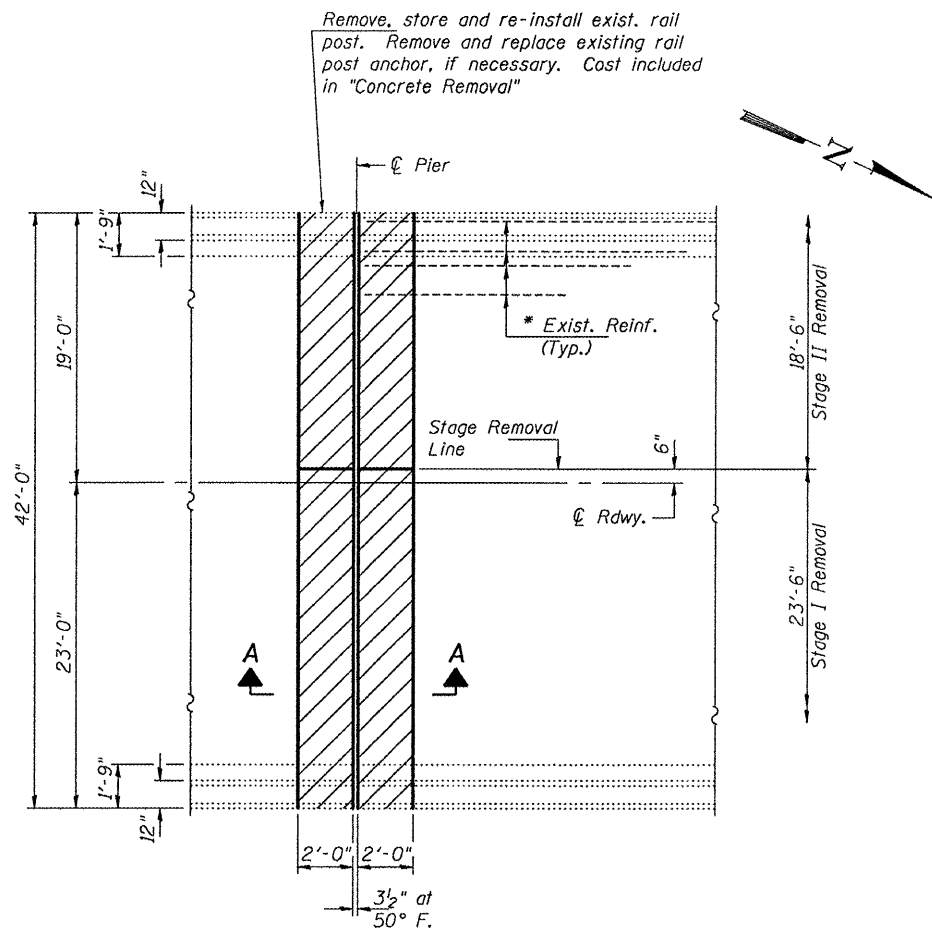

PARTIAL PLAN SHOWING CONCRETE REMOVAL

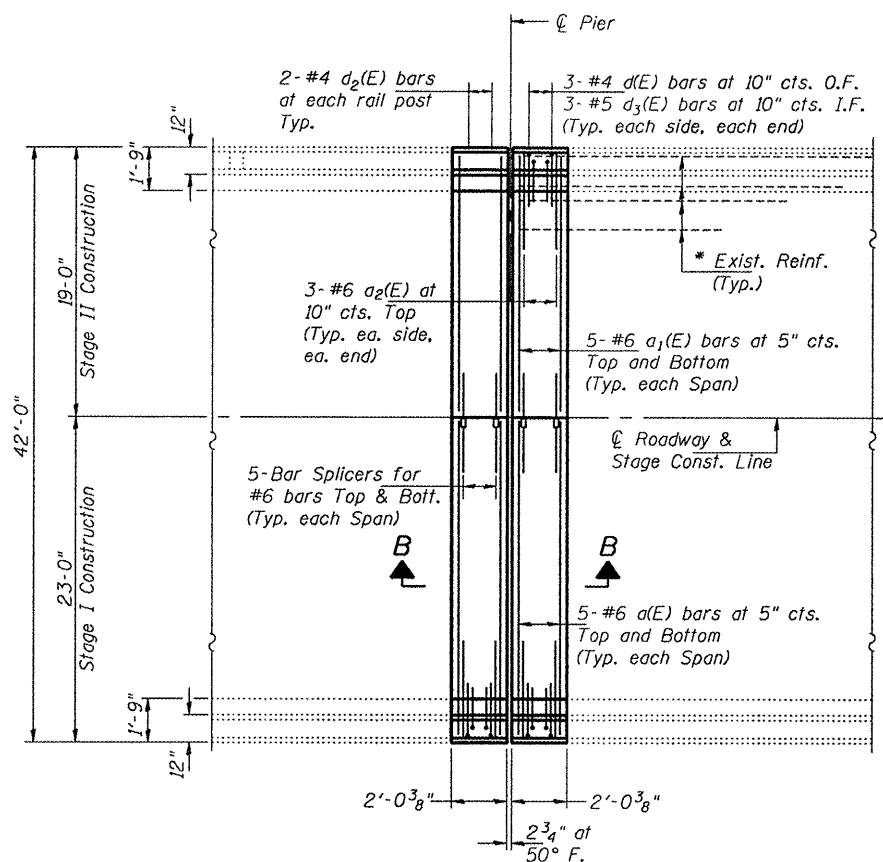

PARTIAL PLAN SHOWING CONCRETE REPLACEMENT

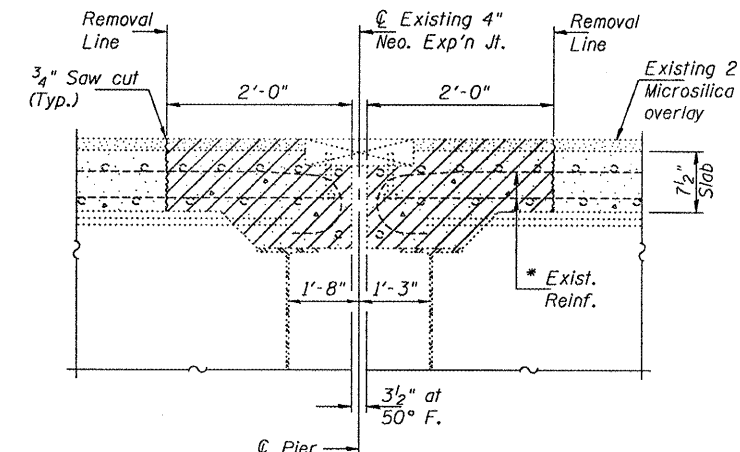

SECTION A-A

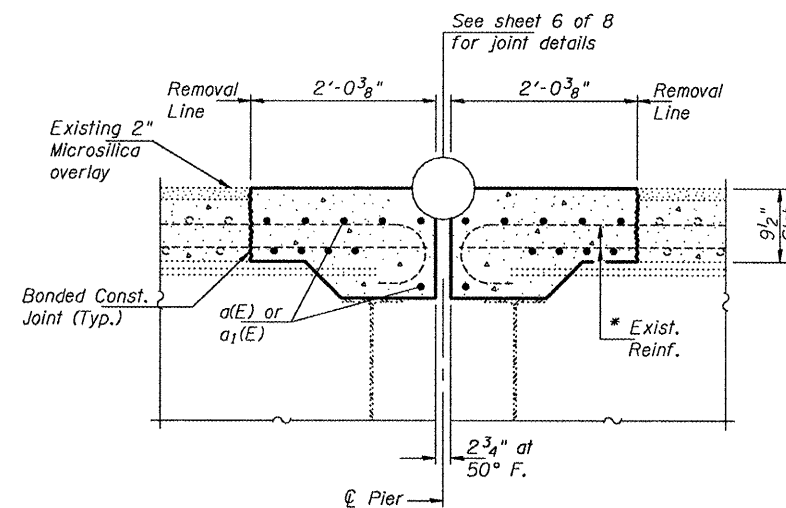

SECTION B-B

BILL OF MATERIAL

Bar	No.	Size	Length	Shape
a(E)	100	#6	21'-6"	—
a1(E)	100	#6	17'-6"	—
a2(E)	60	#6	4'-0"	—
d(E)	60	#4	4'-7"	L
d2(E)	12	#4	2'-1"	L
d3(E)	60	#5	3'-7"	L
Concrete Removal			Cu. Yd.	42.7
Concrete Superstructure			Cu. Yd.	42.7
Reinforcement Bars, Epoxy Coated			Pounds	6,640

* Existing longitudinal reinforcement extending into the removal area shall be cleaned, straightened and incorporated into the new construction. Any reinforcement bars that are damaged during concrete removal shall be replaced with an approved bar splicer or anchorage system. Cost shall be included with Concrete Removal.

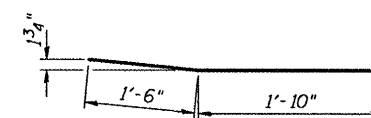

BAR a2(E)

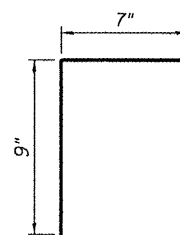

BAR d2(E)

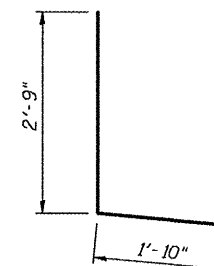

BAR d(E)

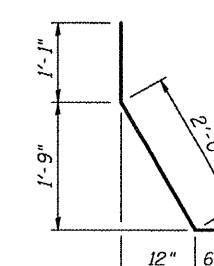

BAR d3(E)

PIERS 4, 6, 9, 12 AND 18

JOINT DETAILS

SN 016-2467

DESIGNED	A.T.H.
CHECKED	G.G.E.
DRAWN	Drew Christopher
CHECKED	A.T.H. G.G.E.

EXAMINED	May 3, 2010
PASSED	Carl Proyer ENGINEER OF STRUCTURAL SERVICES
	Ralph E. Anderson ENGINEER OF BRIDGES AND STRUCTURES

SHEET NO. 4	F.A.P. RTE. 330	SECTION 2009-1331	COUNTY Cook	TOTAL SHEETS 28	SHEET NO. 9
8 SHEETS			CONTRACT NO. 60H89		
FED. ROAD DIST. NO.		ILLINOIS FED. AID PROJECT			

STATE OF ILLINOIS
DEPARTMENT OF TRANSPORTATION

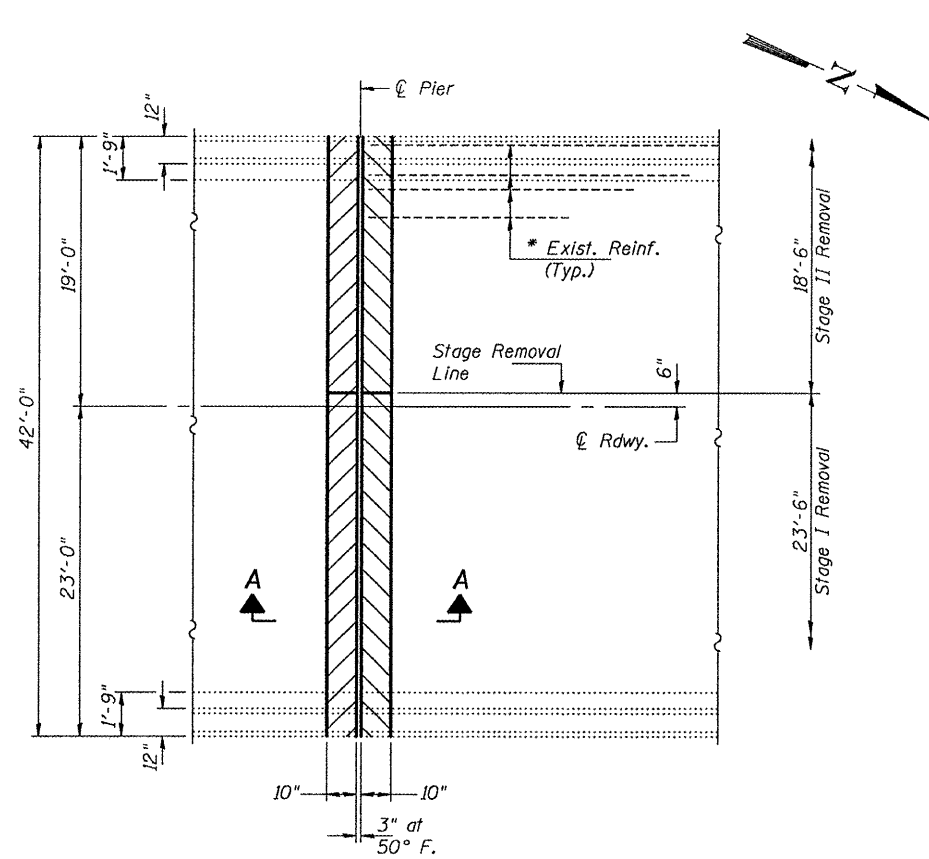

PARTIAL PLAN SHOWING CONCRETE REMOVAL

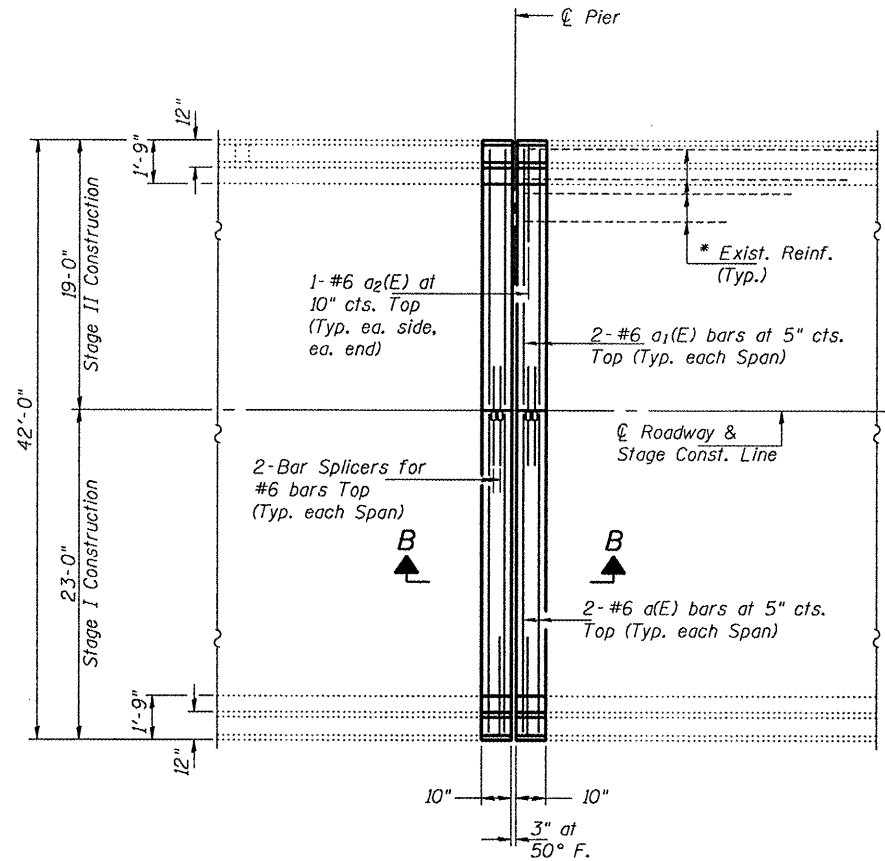

PARTIAL PLAN SHOWING CONCRETE REPLACEMENT

* Existing reinforcement extending into the removal area shall be cleaned, straightened and incorporated into the new construction. Any reinforcement bars that are damaged during concrete removal shall be replaced with an approved bar splicer or anchorage system. Cost shall be included with Concrete Removal.

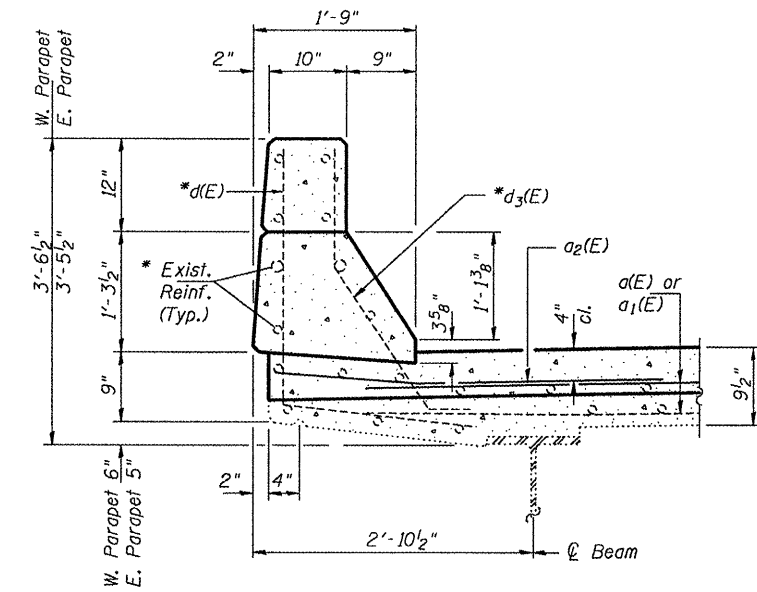

TYPICAL SECTION THRU CURB

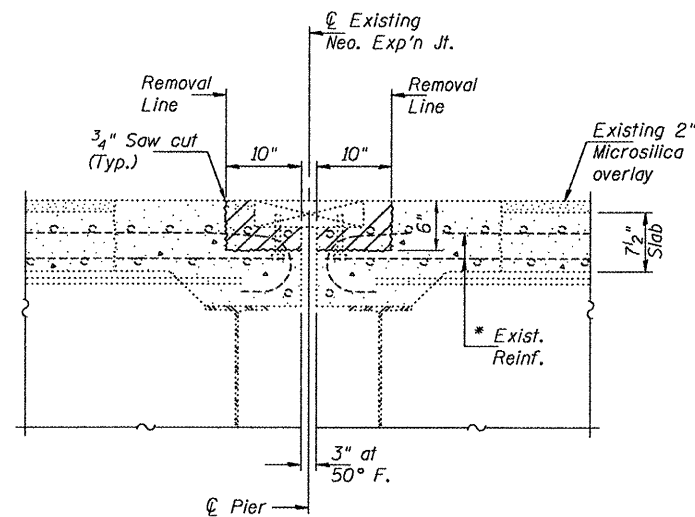

SECTION A-A

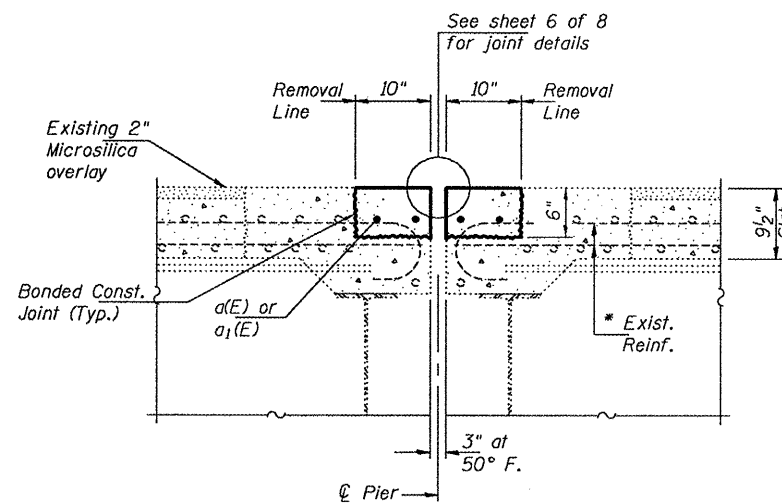

SECTION B-B

BILL OF MATERIAL

Bar	No.	Size	Length	Shape
a(E)	12	#6	21'-6"	—
a1(E)	12	#6	17'-6"	—
a2(E)	12	#6	4'-0"	—
Concrete Removal			Cu. Yd.	4.8
Concrete Superstructure			Cu. Yd.	4.8
Reinforcement Bars, Epoxy Coated			Pounds	780

PIERS 15, 21 AND 29

JOINT DETAILS

SN 016-2467

DESIGNED	A.T.H.
CHECKED	G.G.E.
DRAWN	Drew Christopher
CHECKED	A.T.H. G.G.E.

EXAMINED	May 3, 2010
PASSED	Carl Perry ENGINEER OF STRUCTURAL SERVICES
	Ralph E. Anderson ENGINEER OF BRIDGES AND STRUCTURES

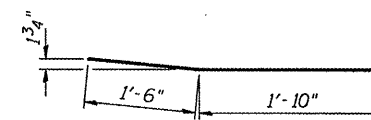

BAR a2(E)

SHEET NO. 5	F.A.P. RTE.	SECTION	COUNTY	TOTAL SHEETS	SHEET NO.
	330	2009-1331	Cook	28	10
8 SHEETS	CONTRACT NO.		60H89		
FED. ROAD DIST. NO.		ILLINOIS	FED. AID PROJECT		

STATE OF ILLINOIS
DEPARTMENT OF TRANSPORTATION

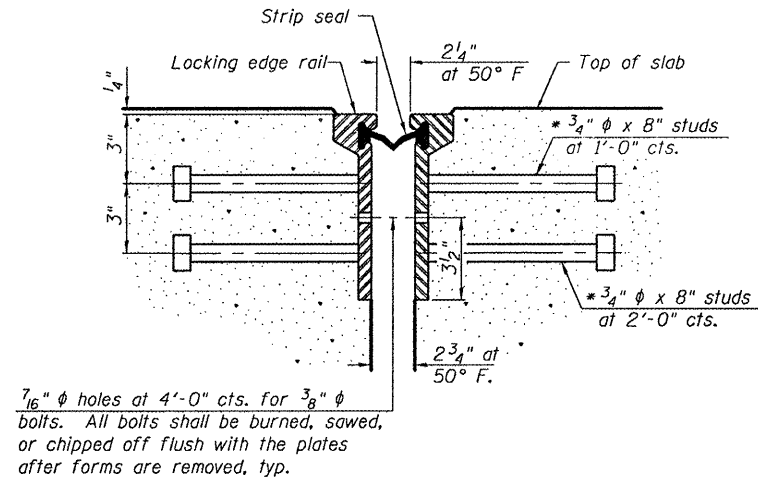

**SECTION THRU
ROLLED RAIL JOINT**

AT PIERS 4, 6, 9, 12 AND 18

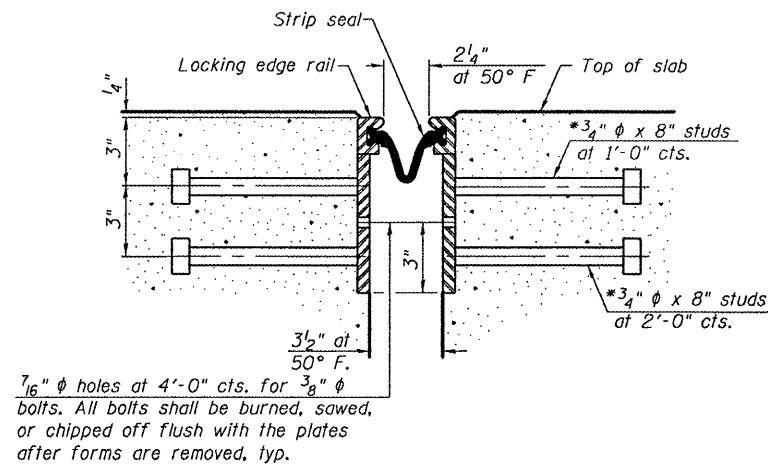

**SECTION THRU
WELDED RAIL JOINT**

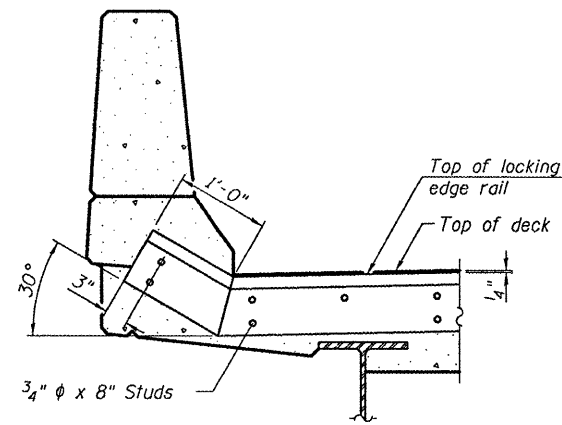

AT PARAPET

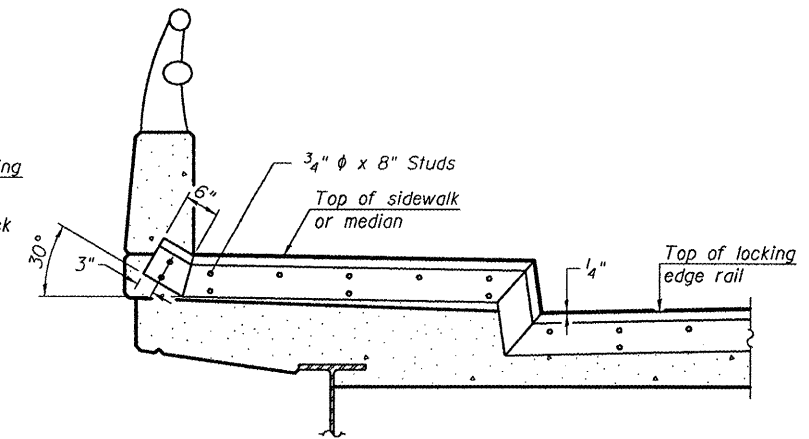

AT SIDEWALK OR MEDIAN

Shorter plates with a single row of studs at 12" cts. may be necessary on medians which are shallower than 9". See manufacturer's recommendation.

* Granular or solid flux filled headed studs conforming to Article 1006.32 of the Std. Specs., automatically end welded.

TYPICAL END TREATMENTS

Notes:

The strip seal shall be made continuous and shall have a minimum thickness of 1/4". The configuration of the strip seal shall match the configuration of the Locking Edge Rails. Open or "webbed" strip seal gland configurations are not permitted. The gland shall be sized for a maximum rated movement of 4 inches. The Locking Edge Rails depicted are conceptual only, except for the minimum dimensions shown. The actual configuration of the Locking Edge Rails and matching strip seal may vary from manufacturer to manufacturer. Flanged edge rails will not be allowed. Locking Edge Rails may be spliced at slope discontinuities.

The manufacturer's recommended installation methods shall be followed. The joint opening and deck dimensions detailed on the superstructure are based on a rolled rail expansion joint. If the Contractor elects to use the welded rail expansion joint, the opening and deck dimensions shall be modified according to the dimensions detailed on this sheet. Required modifications shall be made at no additional cost to the State.

All steel components shall be galvanized after fabrication according to Article 520.03 of the Standard Specifications. Maximum space between rail segments at stage lines shall be 3/16", sealed with a suitable sealant.

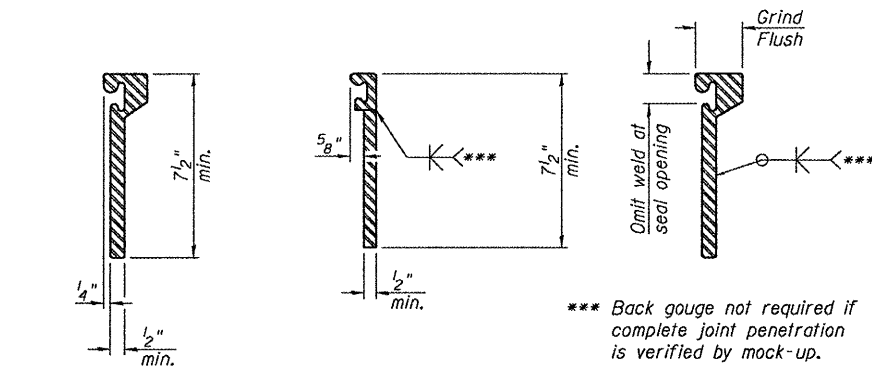

**ROLLED
EXTRUDED RAIL**

WELDED RAIL

**LOCKING EDGE
RAIL SPLICE**

The inside of the locking edge rail groove shall be free of weld residue. Rolled rail shown, welded rail similar.

LOCKING EDGE RAILS

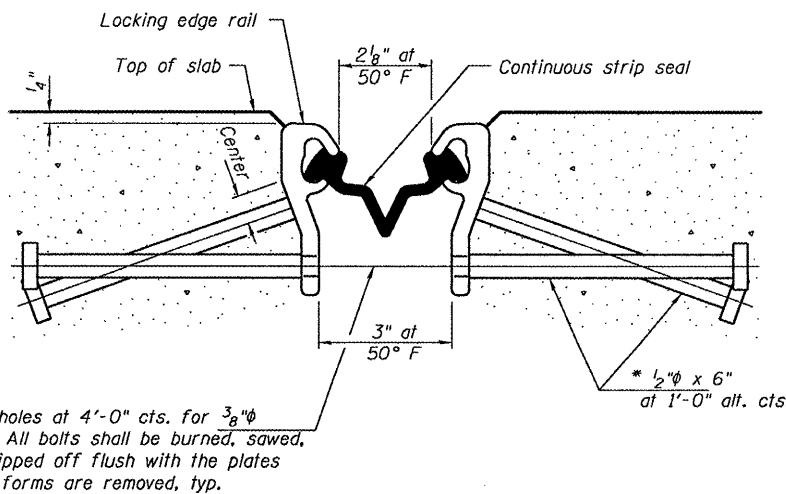

**SECTION THRU SHALLOW STRIP SEAL JOINT
AT PIERS 15, 21 AND 29**

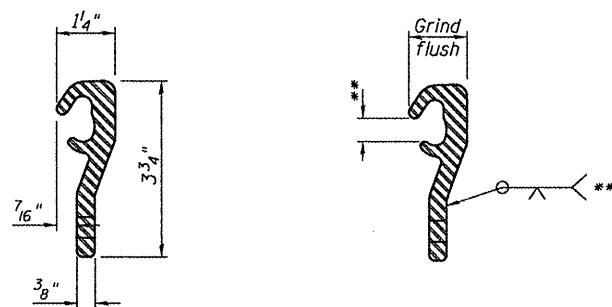

LOCKING EDGE RAIL LOCKING EDGE RAIL SPLICE

** Omit weld at seal opening.

BILL OF MATERIAL

Item	Unit	Total
Preformed Joint Strip Seal	Foot	324

**STRIP SEAL DETAILS DETAILS
SN 016-2467**

SHEET NO.	F.A.P. RTE.	SECTION	COUNTY	TOTAL SHEETS	SHEET NO.
6	330	2009-1331	Cook	28	11
8 SHEETS		CONTRACT NO.		60H89	
FED. ROAD DIST. NO.		ILLINOIS FED. AID PROJECT			

DESIGNED	A.T.H.
CHECKED	G.G.E.
DRAWN	Drew Christopher
CHECKED	A.T.H. G.G.E.

EXAMINED	May 3, 2010 A. Carl Hoover ENGINEER OF STRUCTURAL SERVICES
PASSED	Ralph E. Anderson ENGINEER OF BRIDGES AND STRUCTURES

STATE OF ILLINOIS
DEPARTMENT OF TRANSPORTATION

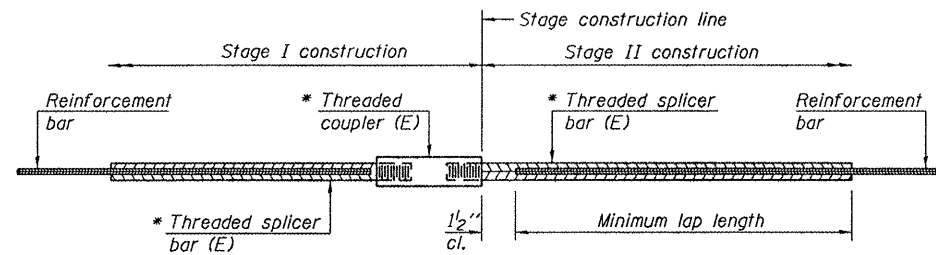

STANDARD BAR SPLICER ASSEMBLY

Bar size to be spliced	Minimum Lap Lengths			
	Table 1	Table 2	Table 3	Table 4
3, 4	1'-5"	1'-11"	2'-1"	2'-4"
5	1'-9"	2'-5"	2'-7"	2'-11"
6	2'-1"	2'-11"	3'-1"	3'-6"
7	2'-9"	3'-10"	4'-2"	4'-8"
8	3'-8"	5'-1"	5'-5"	6'-2"
9	4'-7"	6'-5"	6'-10"	7'-9"

Table 1: Black bar, 0.8 Class C
Table 2: Black bar, Top bar lap, 0.8 Class C
Table 3: Epoxy bar, 0.8 Class C
Table 4: Epoxy bar, Top bar lap, 0.8 Class C

Threaded splicer bar length = min. lap length + 1/2" + thread length

* Epoxy not required on Bar Splicer Assembly components used in conjunction with black bars.

Location	Bar size	No. assemblies required	Table for minimum lap length
Deck	#6	112	3

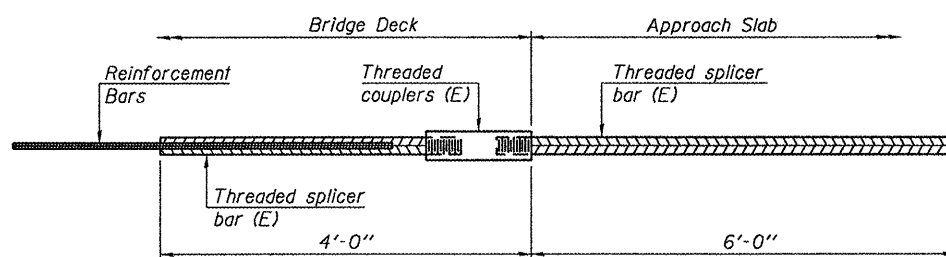

BAR SPLICER ASSEMBLY FOR #5 BAR ON INTEGRAL OR SEMI-INTEGRAL ABUTMENTS

No. required =

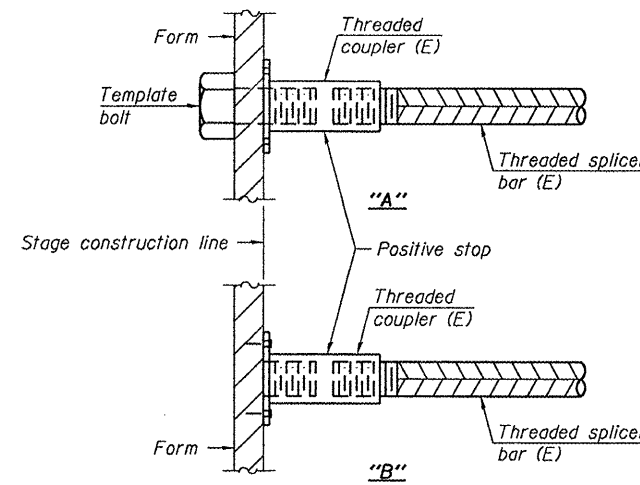

INSTALLATION AND SETTING METHODS

"A" : Set bar splicer assembly by means of a template bolt.
"B" : Set bar splicer assembly by nailing to wood forms or cementing to steel forms.
(E) : Indicates epoxy coating.

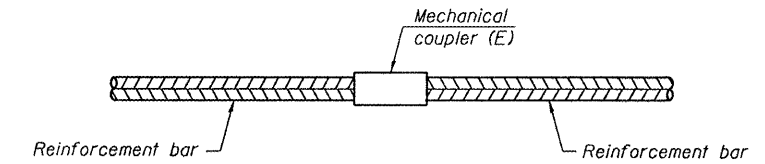

STANDARD MECHANICAL SPLICER

Location	Bar size	No. assemblies required

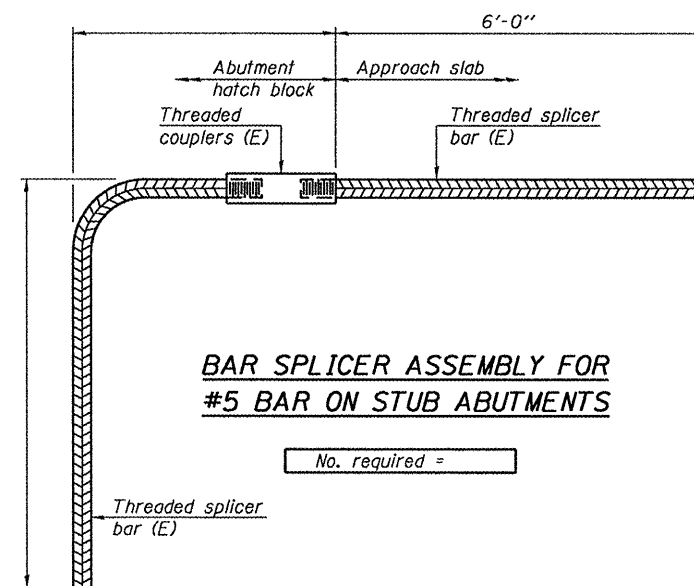

BAR SPLICER ASSEMBLY FOR #5 BAR ON STUB ABUTMENTS

No. required =

NOTES

Splicer bars shall be deformed with threaded ends and have a minimum 60 ksi yield strength.
All reinforcement shall be lapped and tied to the splicer bars.
Bar splicer assemblies shall be epoxy coated according to the requirements for reinforcement bars. See Section 508 of the Standard Specifications.
See special provision for Mechanical Splicers.
See approved list of bar splicer assemblies and mechanical splicers for alternatives.

DESIGNED A.T.H.
CHECKED G.G.E.
DRAWN Drew Christopher
CHECKED A.T.H. G.G.E.

May 3, 2010
EXAMINED *A. Carl Hoover*
ENGINEER OF STRUCTURAL SERVICES
PASSED *Ralph E. Anderson*
ENGINEER OF BRIDGES AND STRUCTURES

BSD-1 11-1-09

**BAR SPLICER DETAILS
SN 016-2467**

SHEET NO. 7 8 SHEETS	F.A.P. RTE. 330	SECTION 2009-133I	COUNTY Cook	TOTAL SHEETS 28	SHEET NO. 12
	CONTRACT NO. 60H89			FED. ROAD DIST. NO. ILLINOIS FED. AID PROJECT	

STATE OF ILLINOIS
DEPARTMENT OF TRANSPORTATION

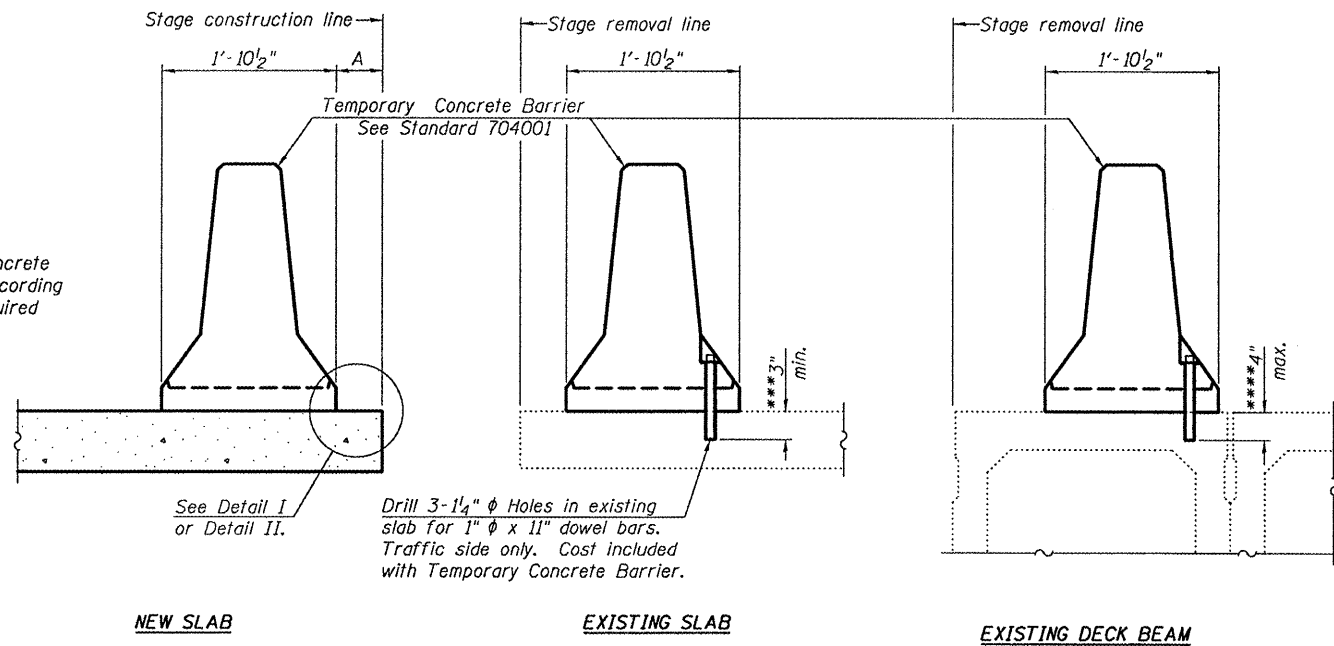

When "A" is 3'-6" or less, the temporary concrete barrier shall be anchored to the new slab according to Detail I or Detail II. No anchorage is required when "A" is greater than 3'-6".

NEW SLAB

Drill 3-1 1/4" ϕ Holes in existing slab for 1" ϕ x 11" dowel bars. Traffic side only. Cost included with Temporary Concrete Barrier.

EXISTING SLAB

EXISTING DECK BEAM

SECTIONS THRU SLAB OR DECK BEAM

NOTES

Detail I - With Bar Splicer or Couplers:
Connect one (1) 1"x7"x10" steel \bar{r} to the top layer of couplers with 2-5/8" ϕ bolts screwed to coupler at approximate \bar{c} of each barrier panel.

Detail II - With Extended Reinforcement Bars:
Connect one (1) 1"x7"x 10" steel \bar{r} to the concrete slab or concrete wearing surface with 2-5/8" ϕ Expansion Anchors or cast in place inserts spaced between the top layer of reinforcement at approximate \bar{c} of each barrier panel.

Cost of anchorage is included with Temporary Concrete Barrier. The 1" x 7" x 10" plate shall not be removed until stage II construction forms and all reinforcement bars are in place and the concrete is ready to be placed.

*** Dimension shown is minimum required embedment into concrete. If hot-mix asphalt wearing surface is present, minimum embedment shall be in addition to wearing surface depth.

**** If existing deck beam is to remain in place after stage construction, embedment shall only be into wearing surface and not into existing deck beam concrete.

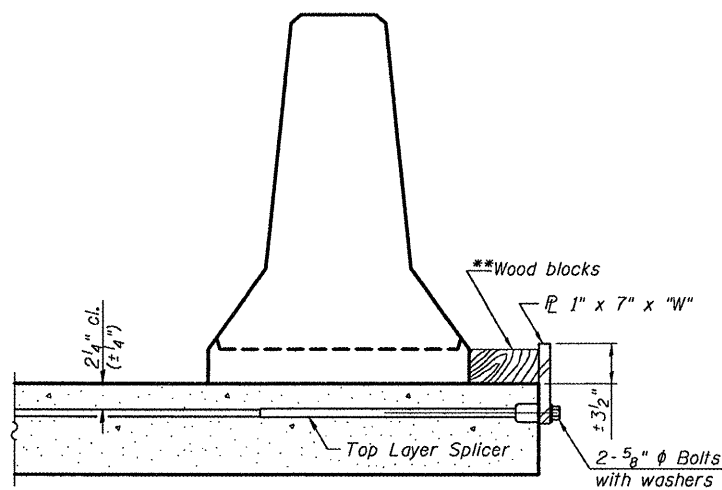

DETAIL I

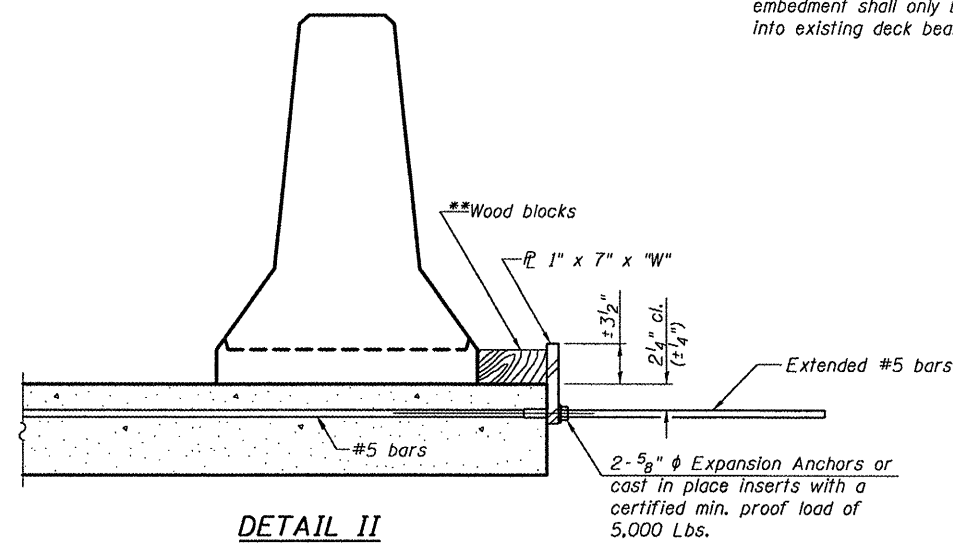

DETAIL II

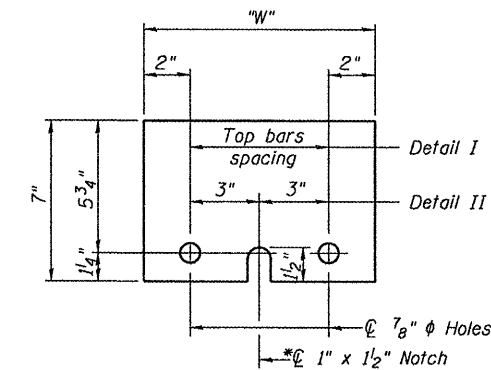

STEEL RETAINER \bar{r} 1" x 7" x 10"

* Required only with Detail II

** Wood blocks may be omitted when required to provide minimum stage traffic lane width. When the wood blocks are omitted, the concrete barrier shall be in direct contact with the steel retainer plate.

"W" = Top bars spacing + 4"

TEMPORARY CONCRETE
BARRIER DETAILS

SN 016-2467

DESIGNED	A.T.H.
CHECKED	G.G.E.
DRAWN	Drew Christopher
CHECKED	A.T.H. G.G.E.

EXAMINED	May 3, 2010
PASSED	Ralph E. Anderson

R-27 11-1-09

SHEET NO. 8	F.A.P. RTE.	SECTION	COUNTY	TOTAL SHEETS	SHEET NO.
	330	2009-133I	Cook	28	13
8 SHEETS	FED. ROAD DIST. NO.		CONTRACT NO. 60H89		
ILLINOIS FED. AID PROJECT					

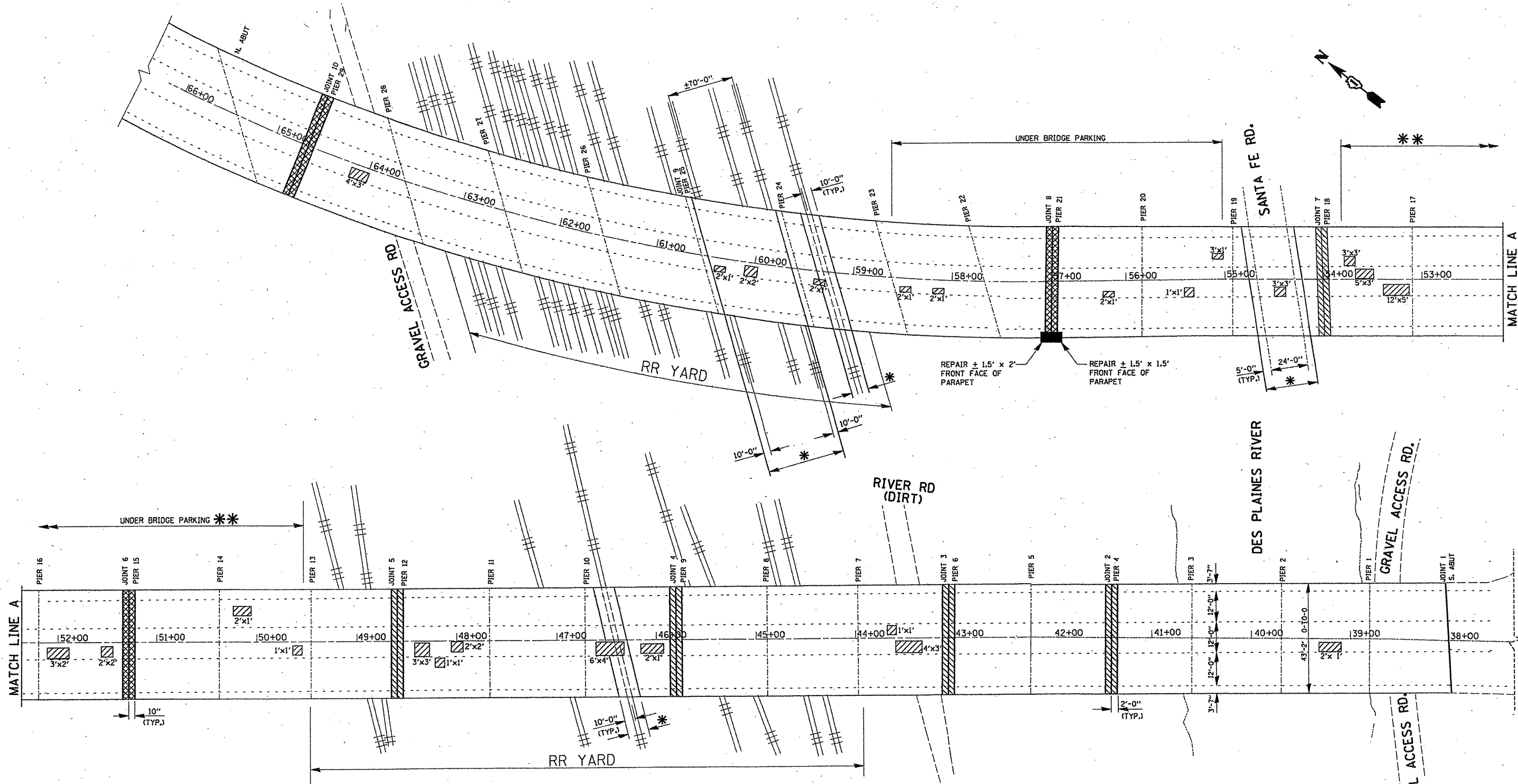

LEGEND:

- DECK SLAB REPAIR (PARTIAL)
- CONCRETE REMOVAL AND CONCRETE SUPERSTRUCTURE (2 FT. EACH SIDE & JOINT FULL DEPTH)
- CONCRETE REMOVAL AND CONCRETE SUPERSTRUCTURE (10" x 6" EACH SIDE OF JOINT) PIERS 15, 21 AND 29
- STRUCTURAL REPAIR OF CONCRETE > 5"
- * LIMITS OF PROTECTIVE SHIELD

BILL OF MATERIALS

ITEM	UNIT	QUANTITY
DECK SLAB REPAIR (PARTIAL)	Sq.Yd.	23
PROTECTIVE SHIELD	Sq.Yd.	1020
STRUCTURAL REPAIR OF CONCRETE >5"	Sq.Ft.	5.3

FILE NAME =	USER NAME = ttrtkoosv	DESIGNED -	REVISED -
cr:\pkl\work\PM1001\TINIAKOSHV\0101671\09-0171.dgn		DRAWN -	REVISED -
PLOT SCALE = 100.0000 / IN.		CHECKED -	REVISED -
PLOT DATE = 4/15/2010		DATE -	REVISED -

**STATE OF ILLINOIS
DEPARTMENT OF TRANSPORTATION**

**US 12/2045 (LAGRANGE ROAD) NB
OVER DES PLAINES RIVER, SANTA FE DR. & RR (S.N. 016-2467)
BRIDGE DECK PATCHING PLAN**

SCALE: SHEET NO. OF SHEETS STA. TO STA.

F.A.P. RTE.	SECTION	COUNTY	TOTAL SHEETS	SHEET NO.
330	2009-133 I	COOK	28	14
CONTRACT NO. 60H89				
ILLINOIS FED. AID PROJECT				

STATE OF ILLINOIS
DEPARTMENT OF TRANSPORTATION

GENERAL NOTES

All structural steel shall conform to AASHTO Classification M-270 Gr. 36, unless otherwise noted.
Reinforcement bars shall conform to the requirements of ASTM A 706 Gr 60. See Special Provisions.
Reinforcement bars designated (E) shall be epoxy coated.
Prior to pouring the new concrete deck, all heavy or loose rust, loose mill scale, and other loose or potentially detrimental foreign material shall be removed from the surfaces in contact with concrete. Tightly adhered paint may remain unless otherwise noted. Removal shall be accomplished by methods that will not damage the steel and the cost will be included in the pay item covering removal of the existing concrete.
Plan dimensions and details relative to existing plans are subject to nominal construction variations. The Contractor shall field verify existing dimensions and details affecting new construction and make necessary approved adjustments prior to construction or ordering of materials. Such variations shall not be cause for additional compensation for a change in scope of the work, however, the Contractor will be paid for the quantity actually furnished at the unit price bid for the work.
Existing reinforcement bars extending into the removal area shall be cleaned, straightened and incorporated into the new construction. Any reinforcement bars that are damaged during concrete removal shall be replaced with an approved bar splicer or anchorage system. Cost included with Concrete Removal.
Joint openings shall be adjusted according to Article 520.04 of the Standard Specifications when the deck is poured at an ambient temperature other than 50° F.
The deck surface shall have its final finish tined according to Article 420.09(e)(1) of the Standard Specifications. Cost included with Concrete Superstructures.
The existing structural steel coating contains lead. The Contractor shall take appropriate precautions to deal with the presence of lead on this project.

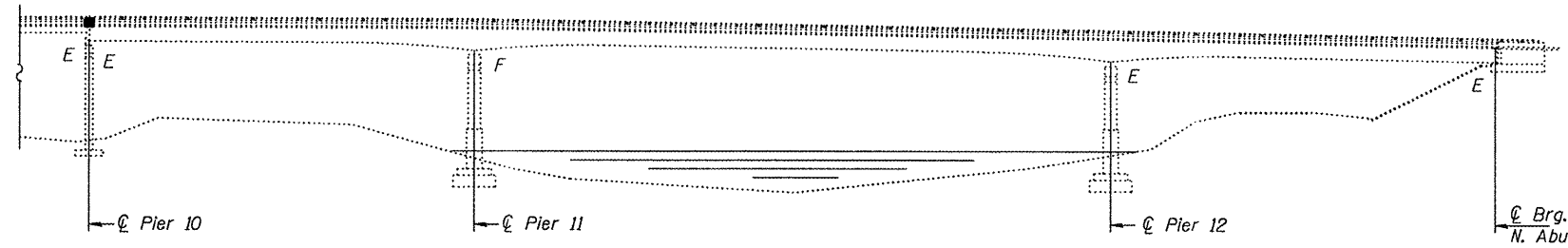
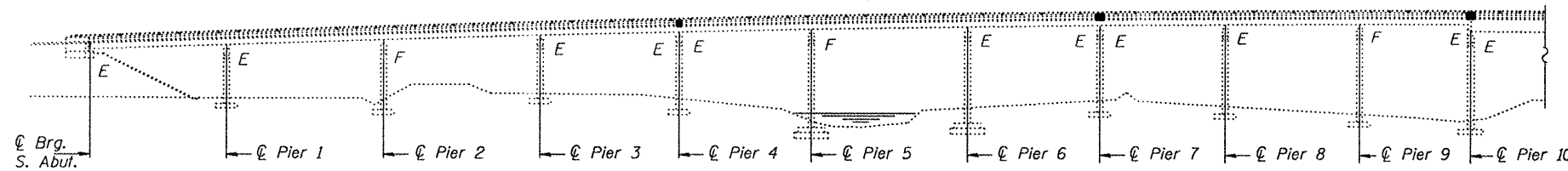

ELEVATION

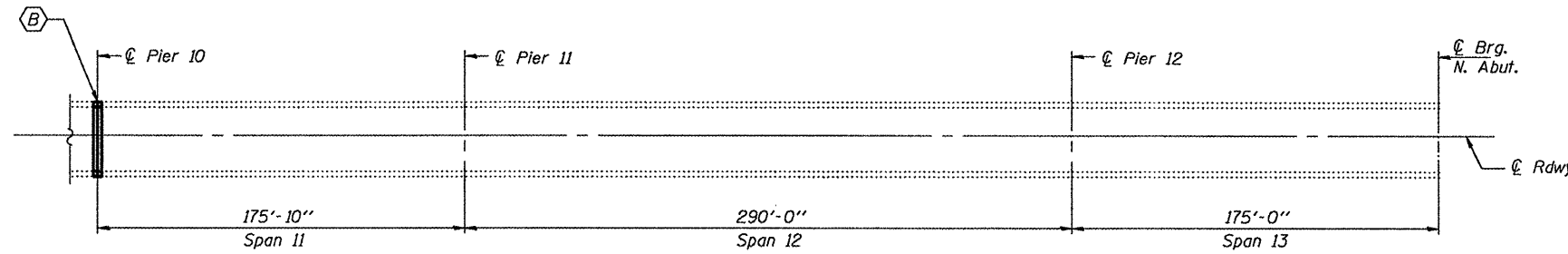
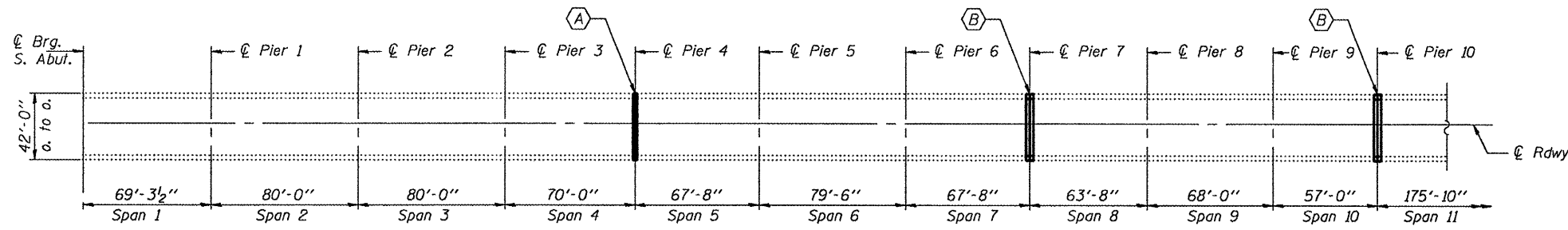

PLAN

- (A) - Remove exist. exp. jt. and install Shallow Preformed Strip Seal
- (B) - Remove exist. exp. jt. and install Preformed Strip Seal

TOTAL BILL OF MATERIAL

ITEM	UNIT	QUANTITY
Concrete Removal	Cu. Yd.	15.1
Concrete Superstructure	Cu. Yd.	15.1
Preformed Joint Strip Seal	Foot	123
Reinforcement Bars, Epoxy Coated	Pound	2910
Bar Splicers	Each	44
Protective Coat	Sq. Yd.	48.5

* New Concrete Only

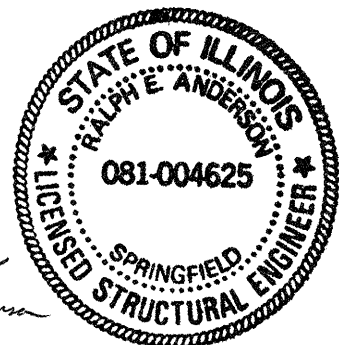

DESIGNED: *[Signature]*
 CHECKED: *[Signature]*
 DRAWN: Kyle M. Steffen
 CHECKED: *[Signature]*
 APRIL 30, 2010
 EXAMINED: *[Signature]*
 PASSED: *[Signature]*
 ENGINEER OF STRUCTURAL SERVICES
 ENGINEER OF BRIDGES AND STRUCTURES

Expires: November 30, 2010

PLAN & ELEVATION
SN 016-2468

SHEET NO. 1 6 SHEETS	F.A.P. RTE.	SECTION	COUNTY	TOTAL SHEETS	SHEET NO.
	330	2009-1331	COOK	28	15
			CONTRACT NO. 60H89		
FED. ROAD DIST. NO.		ILLINOIS	FED. AID PROJECT		

STATE OF ILLINOIS
DEPARTMENT OF TRANSPORTATION

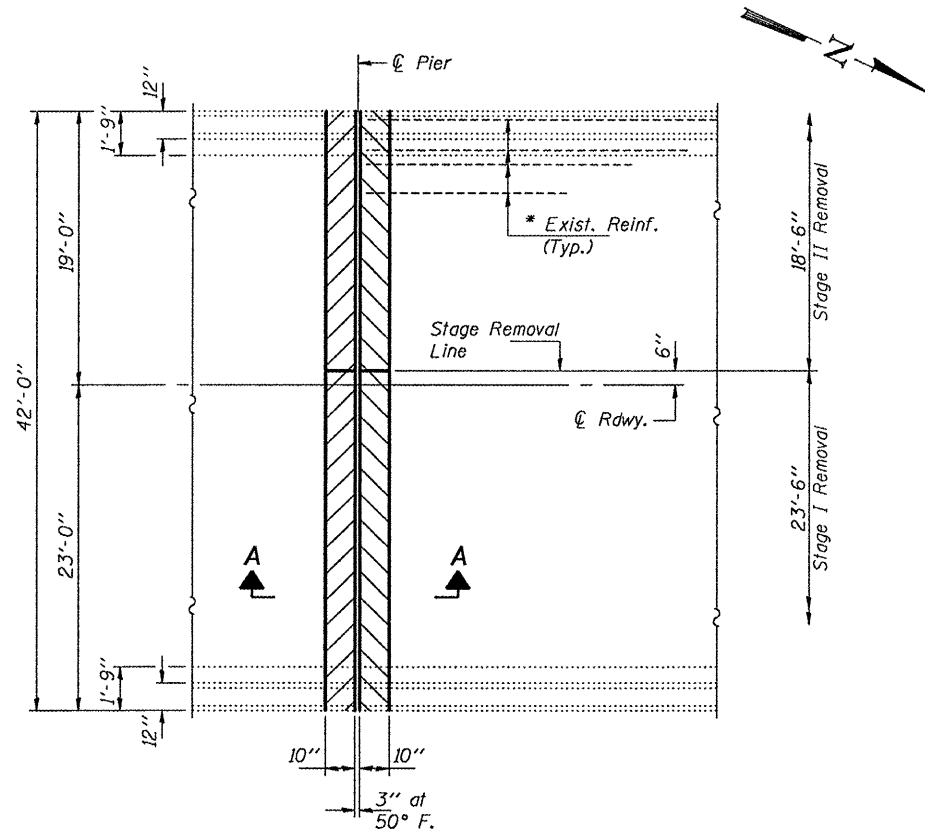

PARTIAL PLAN SHOWING CONCRETE REMOVAL

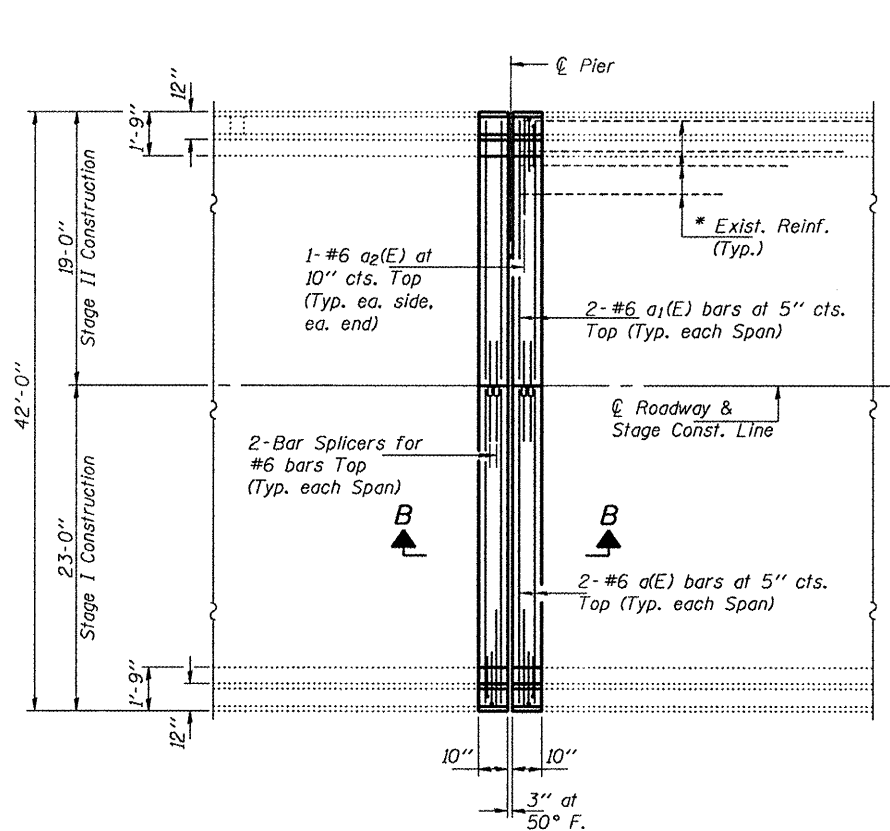

PARTIAL PLAN SHOWING CONCRETE REPLACEMENT

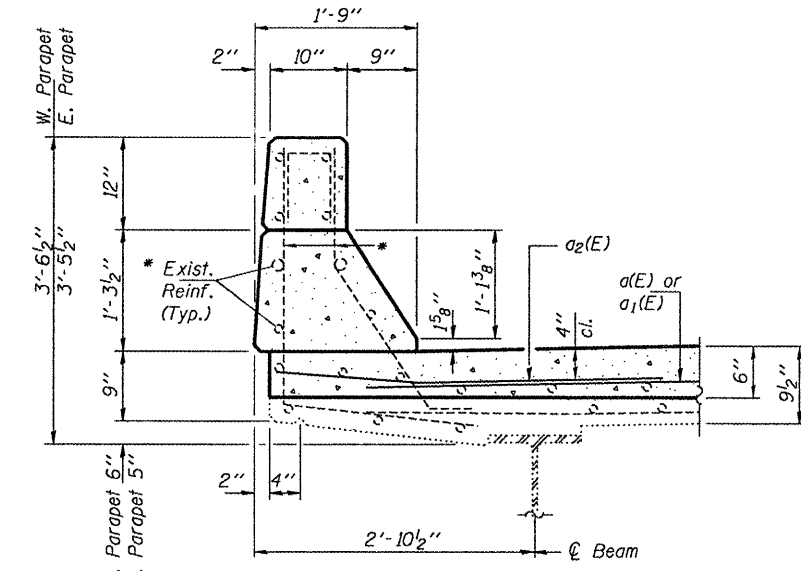

SECTION THRU CURB

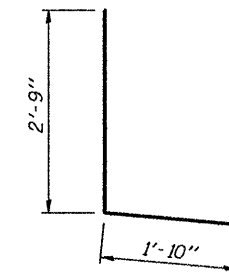

BAR d(E)

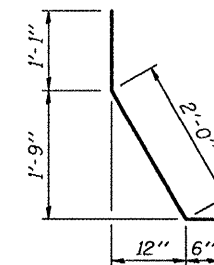

BAR d1(E)

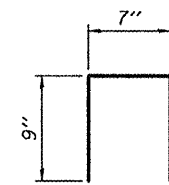

BAR d2(E)

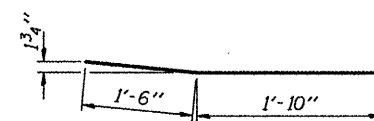

BAR a2(E)

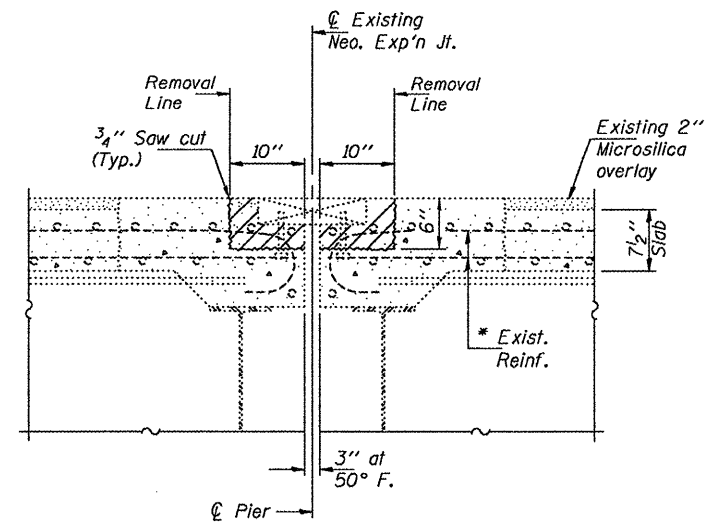

SECTION A-A

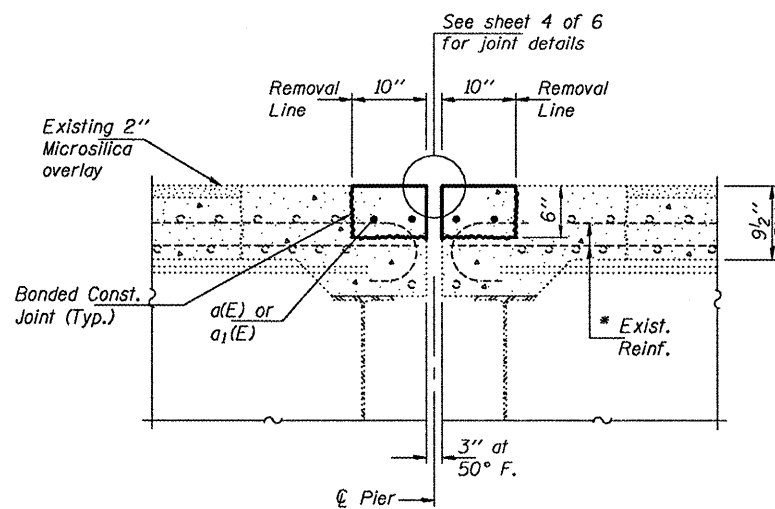

SECTION B-B

BILL OF MATERIAL

Bar	No.	Size	Length	Shape
a(E)	4	#6	21'-6"	—
a1(E)	4	#6	17'-6"	—
a2(E)	4	#6	4'-0"	—
Concrete Removal			Cu. Yd.	1.6
Concrete Superstructure			Cu. Yd.	1.6
Reinforcement Bars, Epoxy Coated			Pounds	260

JOINT REPLACEMENT
DETAILS FOR PIER 4
SN 016-2468

* Existing reinforcement extending into the removal area shall be cleaned, straightened and incorporated into the new construction. Any reinforcement bars that are damaged during concrete removal shall be replaced with an approved bar splicer or anchorage system. Cost shall be included with Concrete Removal.

DESIGNED	ATH
CHECKED	GGE
DRAWN	Kyle M. Steffen
CHECKED	ATH GGE

APRIL 30, 2010
EXAMINED *Carl Power*
ENGINEER OF STRUCTURAL SERVICES
PASSED *Ralph E. Anderson*
ENGINEER OF BRIDGES AND STRUCTURES

SHEET NO. 2 6 SHEETS	F.A.P. RTE. 330	SECTION 2009-1331	COUNTY COOK	TOTAL SHEETS 28	SHEET NO. 16
	CONTRACT NO. 60H89				
FED. ROAD DIST. NO.		ILLINOIS FED. AID PROJECT			

STATE OF ILLINOIS
DEPARTMENT OF TRANSPORTATION

Notes:
See sheet 2 of 6 for Bar Bending details
In lieu of the cast-in-place anchor device shown, the Contractor has the option of drilling and setting stainless steel anchor rods of the same diameter and grade as the specified cap screws according to Article 509.06 of the Standard Specifications. Embedment shall be according to the manufacturer's specifications.

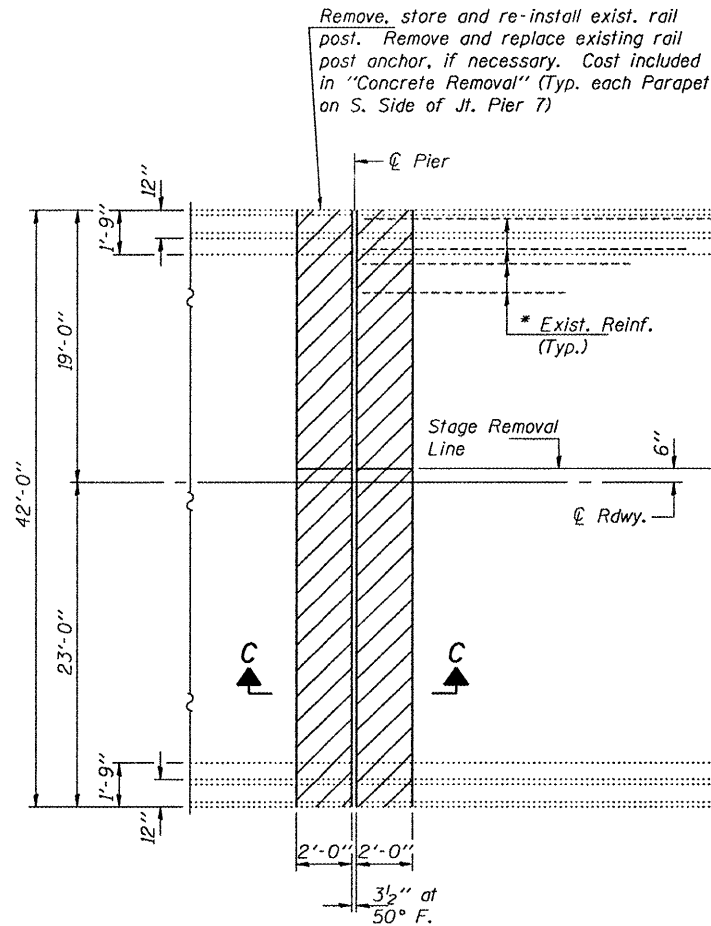

PARTIAL PLAN SHOWING CONCRETE REMOVAL

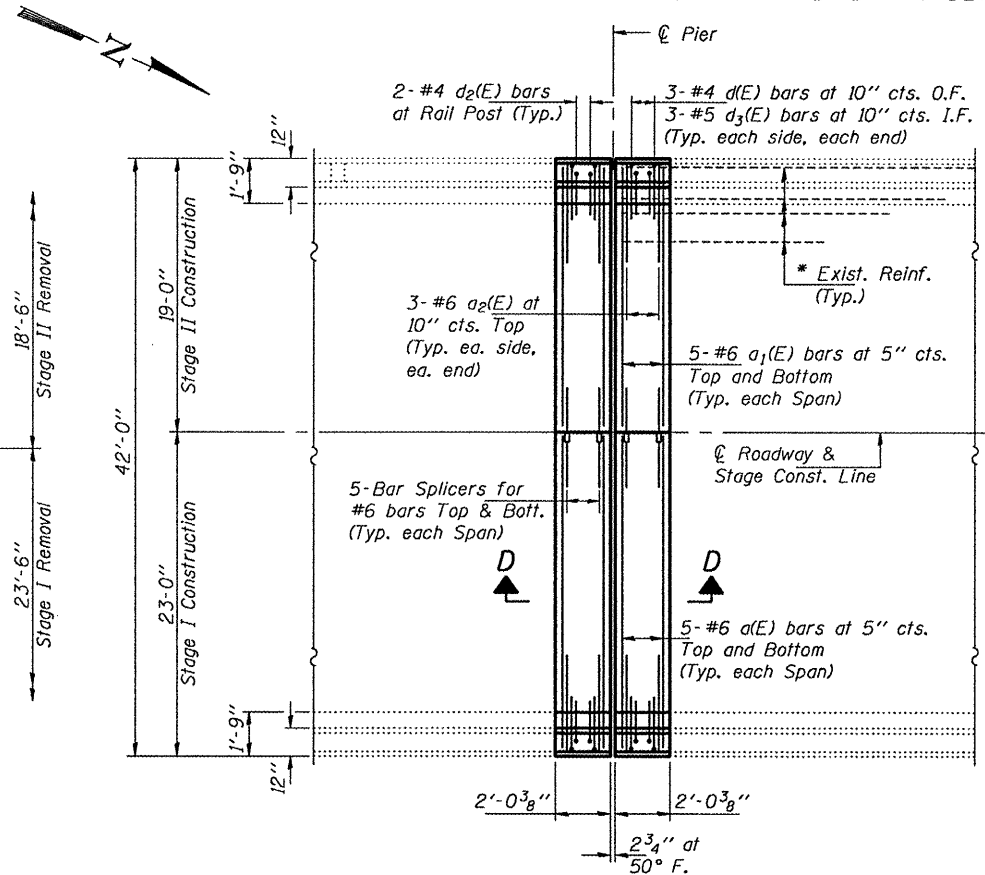

PARTIAL PLAN SHOWING CONCRETE REPLACEMENT

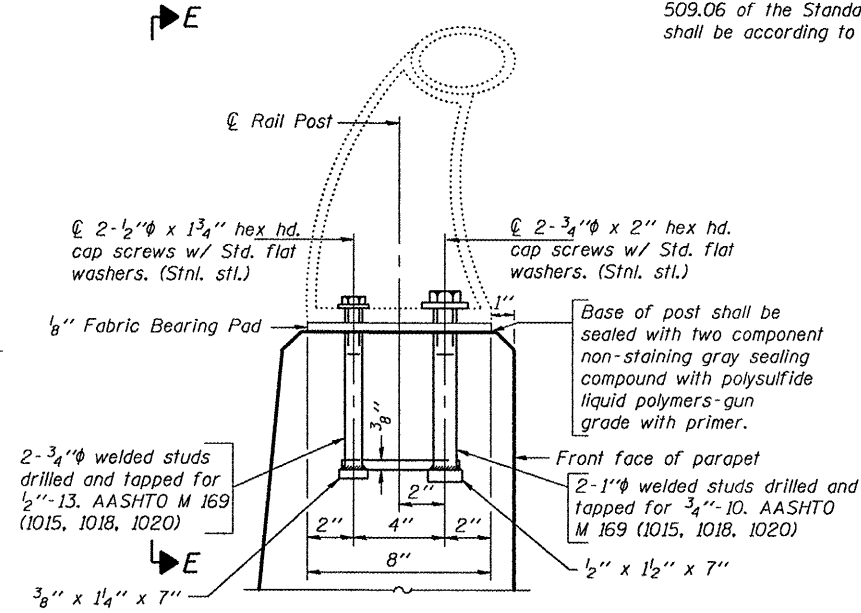

RAIL POST ANCHOR DETAIL

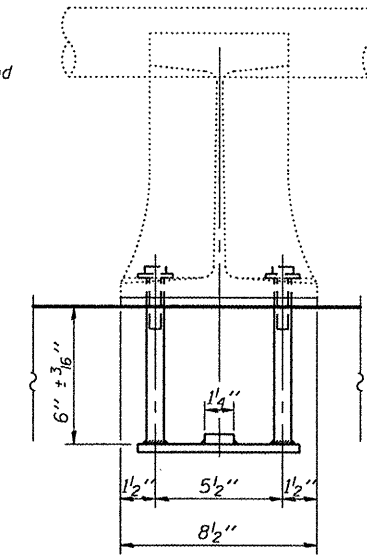

VIEW E-E

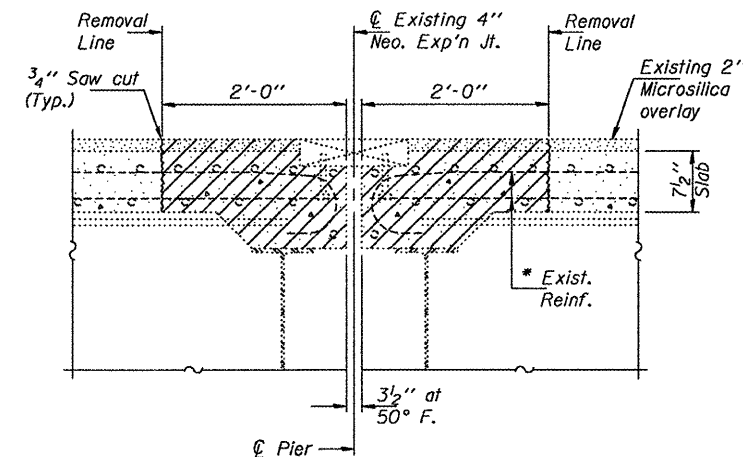

SECTION C-C

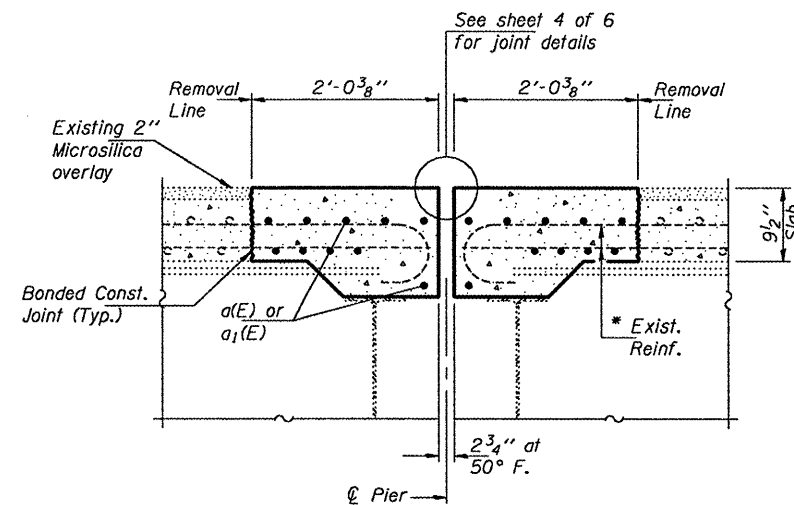

SECTION D-D

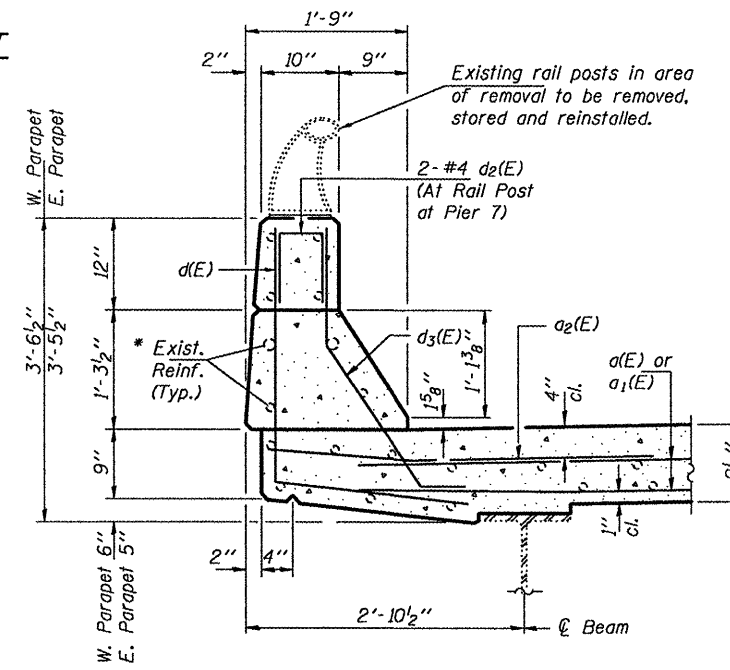

SECTION THRU CURB

BILL OF MATERIAL

Bar	No.	Size	Length	Shape
a(E)	40	#6	21'-6"	—
a1(E)	40	#6	17'-6"	—
a2(E)	24	#6	4'-0"	—
d(E)	24	#4	4'-7"	L
d1(E)	24	#5	3'-7"	L
d2(E)	4	#4	2'-1"	Π
Concrete Removal			Cu. Yd.	13.5
Concrete Superstructure			Cu. Yd.	13.5
Reinforcement Bars, Epoxy Coated			Pounds	2650

JOINT REPLACEMENT
DETAILS FOR PIERS 7 & 10
SN 016-2468

* Existing reinforcement extending into the removal area shall be cleaned, straightened and incorporated into the new construction. Any reinforcement bars that are damaged during concrete removal shall be replaced with an approved bar splicer or anchorage system. Cost shall be included with Concrete Removal.

DESIGNED	ATH
CHECKED	GGE
DRAWN	Kyle M. Steffen
CHECKED	ATH GGE

APRIL 30, 2010
EXAMINED *Carl P. ...*
PASSED *Ralph E. Anderson*
ENGINEER OF STRUCTURAL SERVICES
ENGINEER OF BRIDGES AND STRUCTURES

SHEET NO. 3 6 SHEETS	F.A.P. RTE. 330	SECTION 2009-133I	COUNTY COOK	TOTAL SHEETS 28	SHEET NO. 17
	CONTRACT NO. 60H89				
FED. ROAD DIST. NO.		ILLINOIS	FED. AID PROJECT		

STATE OF ILLINOIS
DEPARTMENT OF TRANSPORTATION

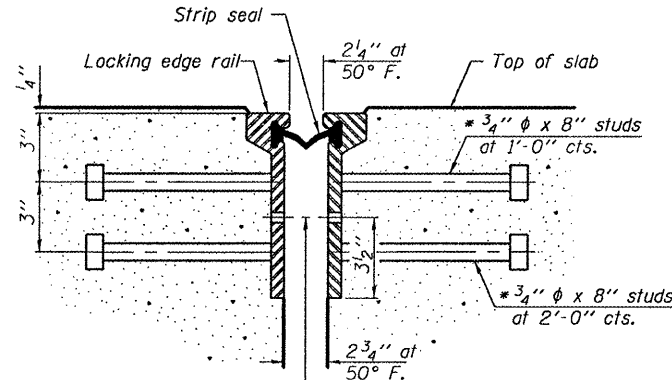

7/16" ϕ holes at 4'-0" cts. for 3/8" ϕ bolts. All bolts shall be burned, sawed, or chipped off flush with the plates after forms are removed, typ.

**SECTION THRU
ROLLED RAIL JOINT**

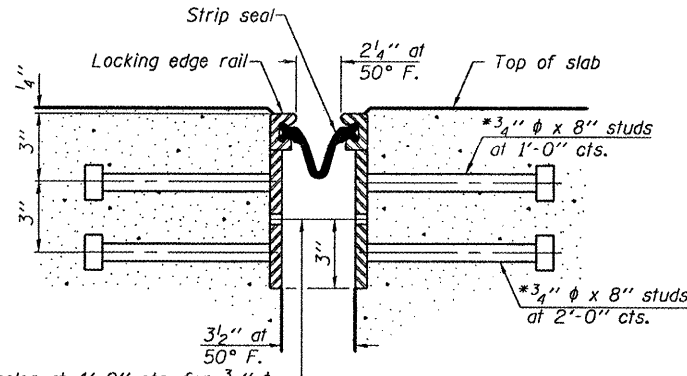

7/16" ϕ holes at 4'-0" cts. for 3/8" ϕ bolts. All bolts shall be burned, sawed, or chipped off flush with the plates after forms are removed, typ.

**SECTION THRU
WELDED RAIL JOINT**

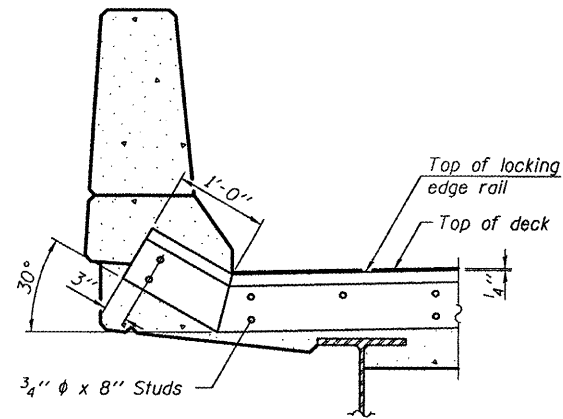

AT PARAPET

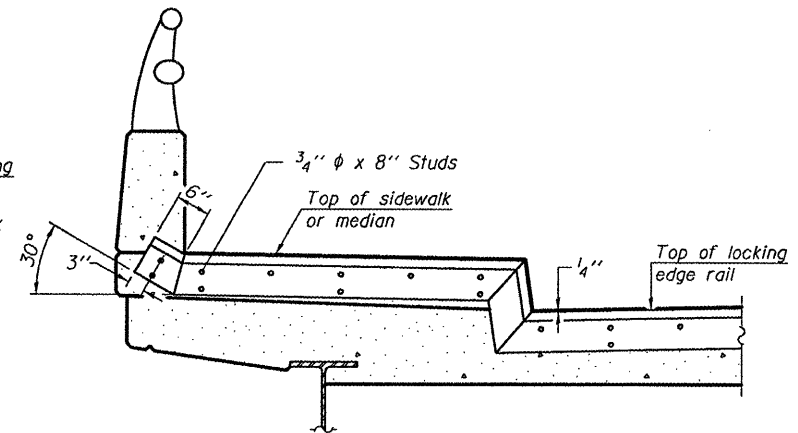

AT SIDEWALK OR MEDIAN

Shorter plates with a single row of studs at 12" cts. may be necessary on medians which are shallower than 9". See manufacturer's recommendation.

TYPICAL END TREATMENTS

AT PIERS 7 & 10

* Granular or solid flux filled headed studs conforming to Article 1006.32 of the Std. Specs., automatically end welded.

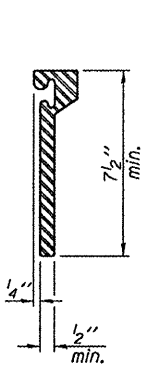

**ROLLED
EXTRUDED RAIL**

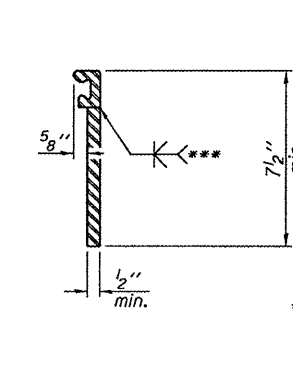

WELDED RAIL

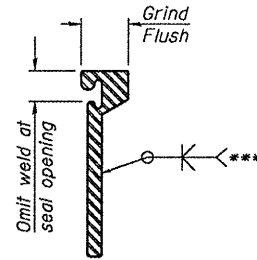

*** Back gouge not required if complete joint penetration is verified by mock-up.

**LOCKING EDGE
RAIL SPLICE**

The inside of the locking edge rail groove shall be free of weld residue.
Rolled rail shown, welded rail similar.

LOCKING EDGE RAILS

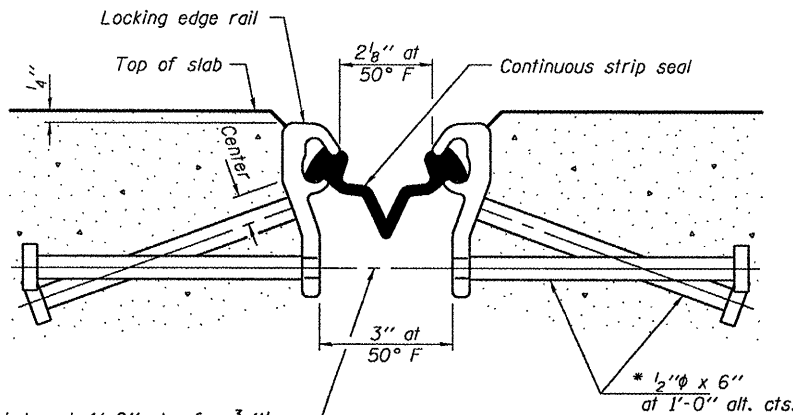

7/16" ϕ holes at 4'-0" cts. for 3/8" ϕ bolts. All bolts shall be burned, sawed, or chipped off flush with the plates after forms are removed, typ.

SECTION THRU SHALLOW STRIP SEAL JOINT AT PIER 4

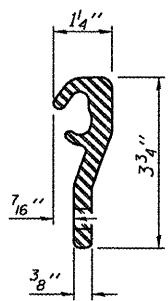

LOCKING EDGE RAIL

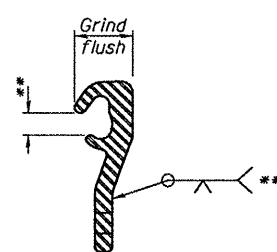

LOCKING EDGE RAIL SPLICE

** Omit weld at seal opening.

Notes:

The strip seal shall be made continuous and shall have a minimum thickness of 1/4". The configuration of the strip seal shall match the configuration of the Locking Edge Rails. Open or "webbed" strip seal gland configurations are not permitted. The gland shall be sized for a maximum rated movement of 4 inches. The Locking Edge Rails depicted are conceptual only, except for the minimum dimensions shown. The actual configuration of the Locking Edge Rails and matching strip seal may vary from manufacturer to manufacturer. Flanged edge rails will not be allowed. Locking Edge Rails may be spliced at slope discontinuities.

The manufacturer's recommended installation methods shall be followed. The joint opening and deck dimensions detailed on the superstructure are based on a rolled rail expansion joint. If the Contractor elects to use the welded rail expansion joint, the opening and deck dimensions shall be modified according to the dimensions detailed on this sheet. Required modifications shall be made at no additional cost to the State.

All steel components shall be galvanized after fabrication according to Article 520.03 of the Standard Specifications.

Maximum space between rail segments at stage lines shall be 3/16", sealed with a suitable sealant.

BILL OF MATERIAL

Item	Unit	Total
Preformed Joint Strip Seal	Foot	123

**PREFORMED JOINT STRIP
SEAL DETAILS
SN 016-2468**

DESIGNED	ATH
CHECKED	GGE
DRAWN	Kyle M. Steffen
CHECKED	ATH GGE

APRIL 30, 2010
EXAMINED *Carl Proyer*
ENGINEER OF STRUCTURAL SERVICES
PASSED *Ralph E. Anderson*
ENGINEER OF BRIDGES AND STRUCTURES

SHEET NO. 4	F.A.P. RTE. 330	SECTION 2009-1331	COUNTY COOK	TOTAL SHEETS 28	SHEET NO. 18
6 SHEETS	CONTRACT NO. 60H89		FED. ROAD DIST. NO. ILLINOIS FED. AID PROJECT		

STATE OF ILLINOIS
DEPARTMENT OF TRANSPORTATION

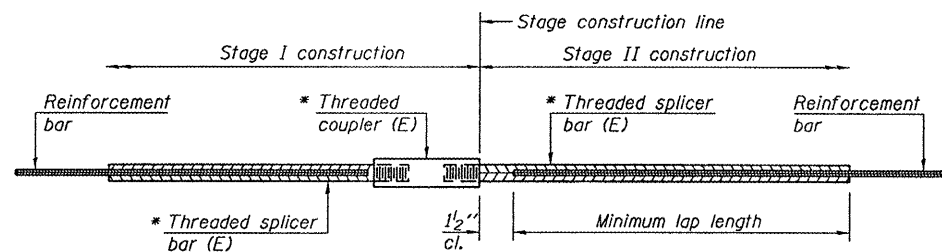

STANDARD BAR SPLICER ASSEMBLY

Bar size to be spliced	Minimum Lap Lengths			
	Table 1	Table 2	Table 3	Table 4
3, 4	1'-5"	1'-11"	2'-1"	2'-4"
5	1'-9"	2'-5"	2'-7"	2'-11"
6	2'-1"	2'-11"	3'-1"	3'-6"
7	2'-9"	3'-10"	4'-2"	4'-8"
8	3'-8"	5'-1"	5'-5"	6'-2"
9	4'-7"	6'-5"	6'-10"	7'-9"

Table 1: Black bar, 0.8 Class C
Table 2: Black bar, Top bar lap, 0.8 Class C
Table 3: Epoxy bar, 0.8 Class C
Table 4: Epoxy bar, Top bar lap, 0.8 Class C

Threaded splicer bar length = min. lap length + 1/2" + thread length

* Epoxy not required on Bar Splicer Assembly components used in conjunction with black bars.

Location	Bar size	No. assemblies required	Table for minimum lap length
Deck	#6	44	3

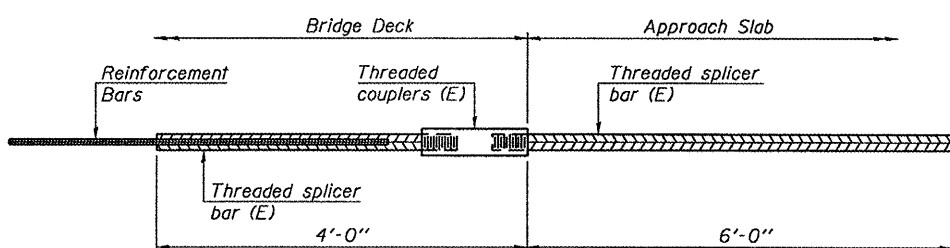

BAR SPLICER ASSEMBLY FOR #5 BAR ON INTEGRAL OR SEMI-INTEGRAL ABUTMENTS

No. required =

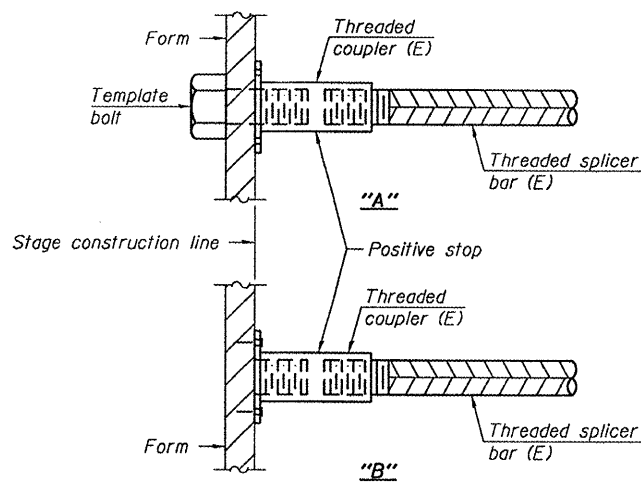

INSTALLATION AND SETTING METHODS

"A" : Set bar splicer assembly by means of a template bolt.
"B" : Set bar splicer assembly by nailing to wood forms or cementing to steel forms.
(E) : Indicates epoxy coating.

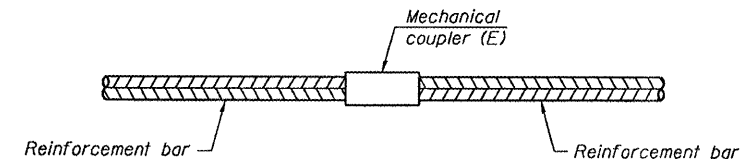

STANDARD MECHANICAL SPLICER

Location	Bar size	No. assemblies required

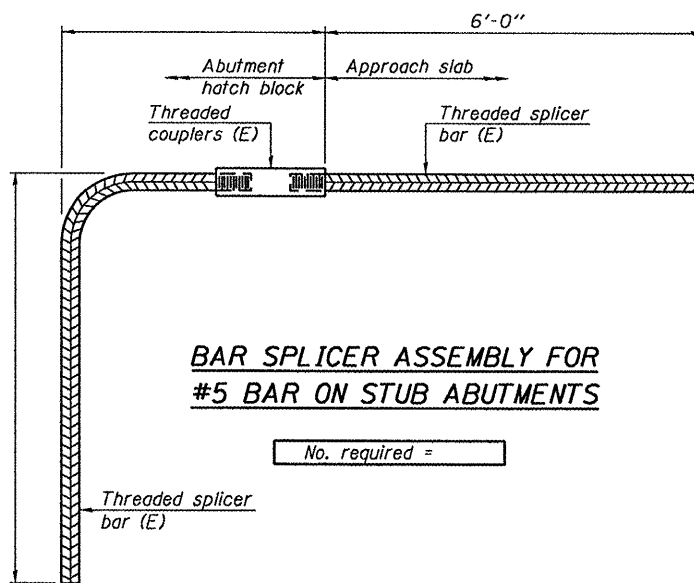

BAR SPLICER ASSEMBLY FOR #5 BAR ON STUB ABUTMENTS

No. required =

NOTES

Splicer bars shall be deformed with threaded ends and have a minimum 60 ksi yield strength.
All reinforcement shall be lapped and tied to the splicer bars.
Bar splicer assemblies shall be epoxy coated according to the requirements for reinforcement bars. See Section 508 of the Standard Specifications.
See special provision for Mechanical Splicers.
See approved list of bar splicer assemblies and mechanical splicers for alternatives.

BAR SPLICER ASSEMBLY & MECHANICAL SPLICER DETAILS
SN 016-2468

DESIGNED	ATH
CHECKED	GGE
DRAWN	Kyle M. Steffen
CHECKED	ATH GGE

APRIL 30, 2010
EXAMINED *A. Carl Perry*
PASSED *Ralph E. Anderson*
ENGINEER OF STRUCTURAL SERVICES
ENGINEER OF BRIDGES AND STRUCTURES

BSD-1 11-1-09

SHEET NO. 5 6 SHEETS	F.A.P. RTE. 330	SECTION 2009-1331	COUNTY COOK	TOTAL SHEETS 28	SHEET NO. 19
	CONTRACT NO. 60H89			FED. ROAD DIST. NO. ILLINOIS FED. AID PROJECT	

STATE OF ILLINOIS
DEPARTMENT OF TRANSPORTATION

When "A" is 3'-6" or less, the temporary concrete barrier shall be anchored to the new slab according to Detail I or Detail II. No anchorage is required when "A" is greater than 3'-6".

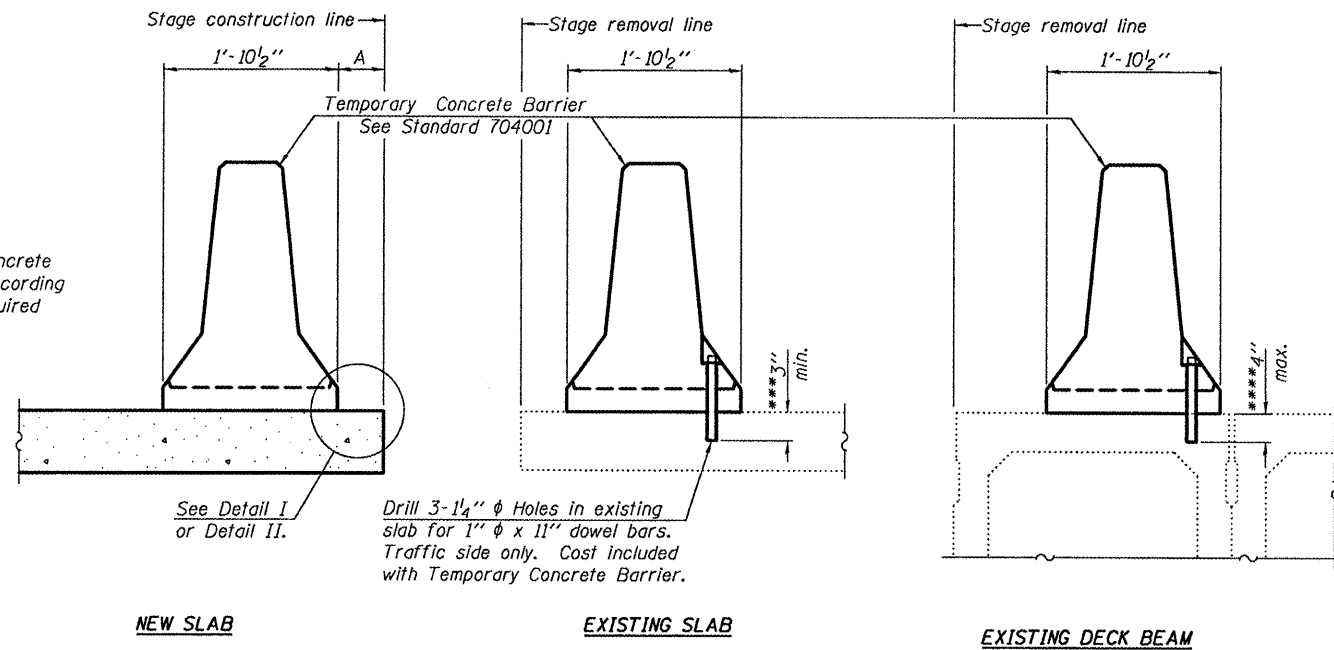

Drill 3-1/4" ϕ Holes in existing slab for 1" ϕ x 11" dowel bars. Traffic side only. Cost included with Temporary Concrete Barrier.

NOTES

- Detail I - With Bar Splicer or Couplers:**
Connect one (1) 1"x7"x10" steel \bar{r} to the top layer of couplers with 2-5/8" ϕ bolts screwed to coupler at approximate \bar{c} of each barrier panel.
- Detail II - With Extended Reinforcement Bars:**
Connect one (1) 1"x7"x10" steel \bar{r} to the concrete slab or concrete wearing surface with 2-5/8" ϕ Expansion Anchors or cast in place inserts spaced between the top layer of reinforcement at approximate \bar{c} of each barrier panel.
- Cost of anchorage is included with Temporary Concrete Barrier. The 1" x 7" x 10" plate shall not be removed until stage II construction forms and all reinforcement bars are in place and the concrete is ready to be placed.

SECTIONS THRU SLAB OR DECK BEAM

*** Dimension shown is minimum required embedment into concrete. If hot-mix asphalt wearing surface is present, minimum embedment shall be in addition to wearing surface depth.

**** If existing deck beam is to remain in place after stage construction, embedment shall only be into wearing surface and not into existing deck beam concrete.

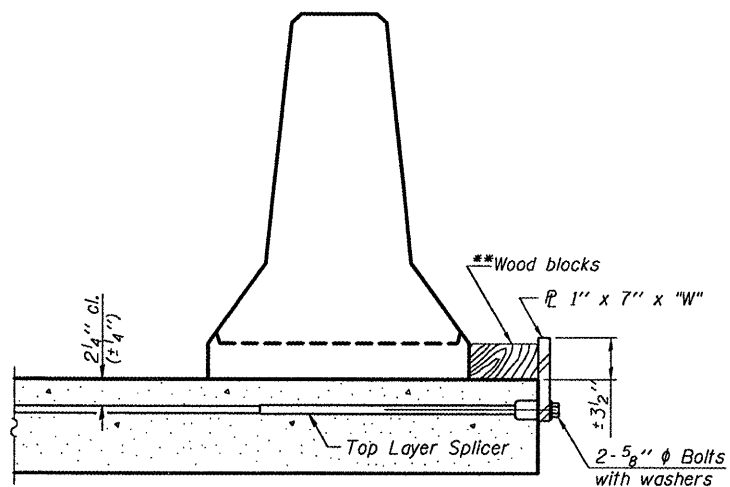

DETAIL I

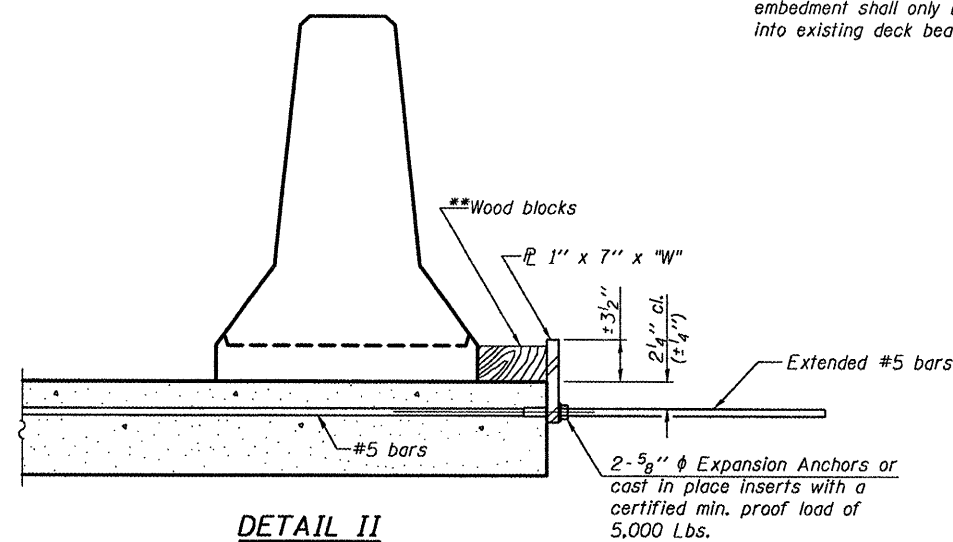

DETAIL II

** Wood blocks may be omitted when required to provide minimum stage traffic lane width. When the wood blocks are omitted, the concrete barrier shall be in direct contact with the steel retainer plate.

"W" = Top bars spacing + 4"

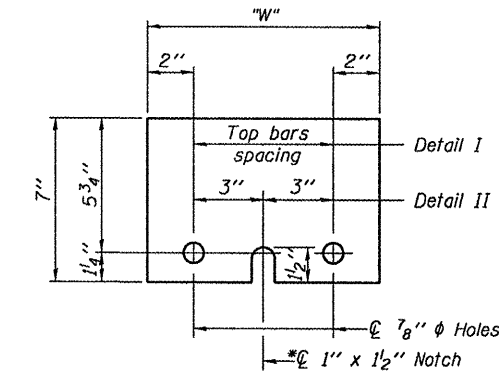

STEEL RETAINER 1" x 7" x 10"

* Required only with Detail II

DESIGNED	ATH
CHECKED	GGE
DRAWN	Kyle M. Steffen
CHECKED	ATH GGE

APRIL 30, 2010
EXAMINED *Carl Prosser*
ENGINEER OF STRUCTURAL SERVICES
PASSED *Ralph E. Anderson*
ENGINEER OF BRIDGES AND STRUCTURES

R-27 11-1-09

**TEMPORARY CONCRETE BARRIER
FOR STAGE CONSTRUCTION
SN 016-2468**

SHEET NO. 6 6 SHEETS	F.A.P. RTE.	SECTION	COUNTY	TOTAL SHEETS	SHEET NO.
	330	2009-133I	COOK	28	20
FED. ROAD DIST. NO.			ILLINOIS FED. AID PROJECT		
CONTRACT NO. 60H89					

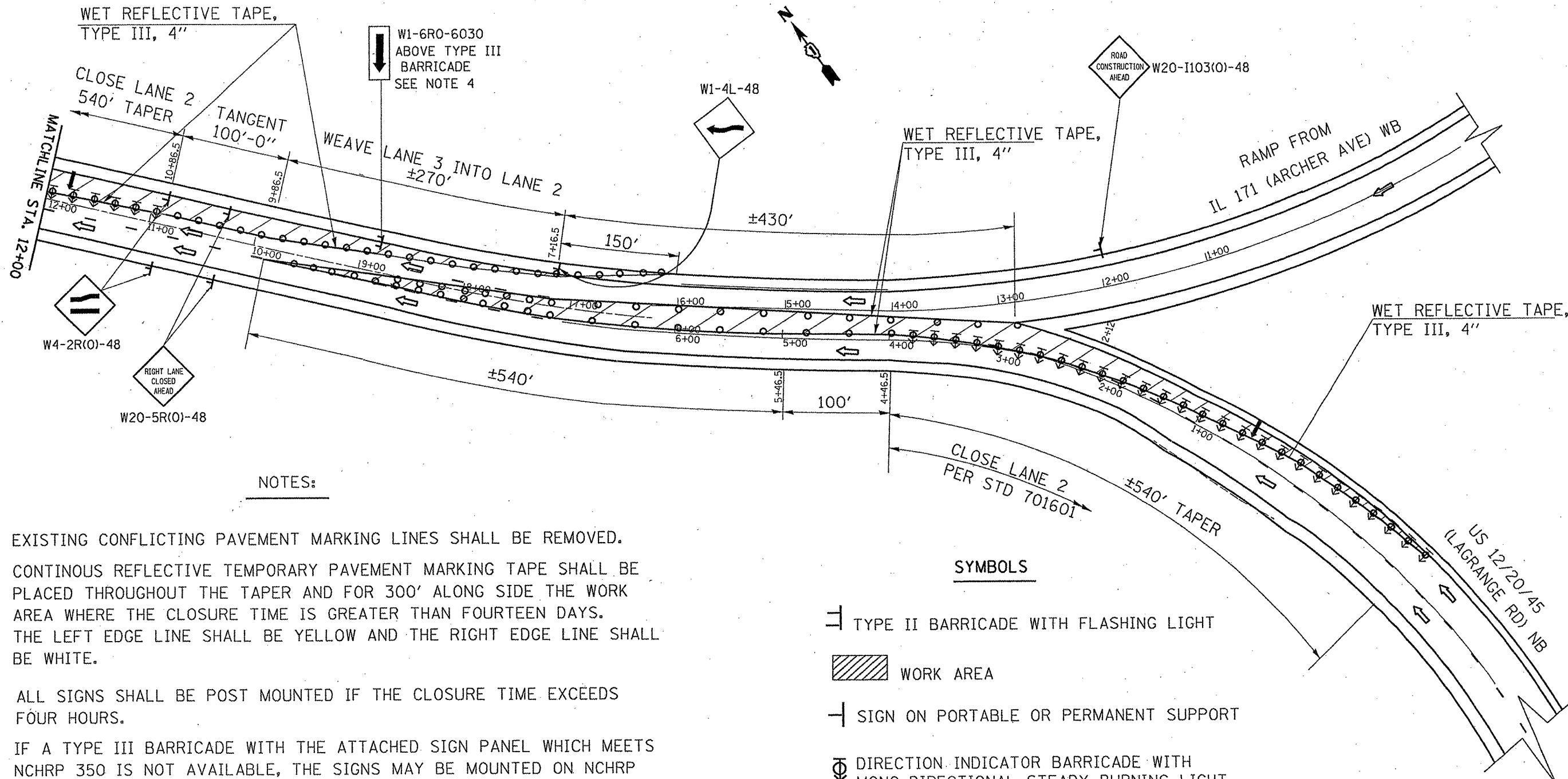

NOTES:

- ① EXISTING CONFLICTING PAVEMENT MARKING LINES SHALL BE REMOVED.
- ② CONTINUOUS REFLECTIVE TEMPORARY PAVEMENT MARKING TAPE SHALL BE PLACED THROUGHOUT THE TAPER AND FOR 300' ALONG SIDE THE WORK AREA WHERE THE CLOSURE TIME IS GREATER THAN FOURTEEN DAYS. THE LEFT EDGE LINE SHALL BE YELLOW AND THE RIGHT EDGE LINE SHALL BE WHITE.
- ③ ALL SIGNS SHALL BE POST MOUNTED IF THE CLOSURE TIME EXCEEDS FOUR HOURS.
- ④ IF A TYPE III BARRICADE WITH THE ATTACHED SIGN PANEL WHICH MEETS NCHRP 350 IS NOT AVAILABLE, THE SIGNS MAY BE MOUNTED ON NCHRP 350 TEMPORARY SIGN SUPPORTS. TYPE III BARRICADES MAY BE OMITTED FOR SINGLE LANE WEAVERS UNDER 24 HOURS IN DURATION. W1-6 SIGNS WILL STILL BE REQUIRED. IF THE WIDTH OF OFFSET IS LESS THAN 6' THEN THE TYPE III BARRICADE WITH ATTACHED ARROW SIGN PANEL CAN BE ELIMINATED IN THE TAPER AREA.

SYMBOLS

- ⊥ TYPE II BARRICADE WITH FLASHING LIGHT
- ▨ WORK AREA
- ⊥ SIGN ON PORTABLE OR PERMANENT SUPPORT
- ⊕ DIRECTION INDICATOR BARRICADE WITH MONO-DIRECTIONAL STEADY BURNING LIGHT
- TYPE II BARRICADE OR DRUM, 20' CTS IN TAPER, 50' IN WEAVE, 100' IN TANGENT
- ➡ ARROW BOARD
- ⇨ DIRECTION OF TRAFFIC

FILE NAME =	USER NAME = gorengautab	DESIGNED -	REVISED -	STATE OF ILLINOIS DEPARTMENT OF TRANSPORTATION	US 1220/45 (LAGRANGE) NB TRAFFIC CONTROL PLAN STAGE 1	F.A.P. RTE.	SECTION	COUNTY	TOTAL SHEETS	SHEET NO.	
c:\pwwork\k\p\w\dot\gorengautab\j0175993	0125210-shr-plan.dgn	DRAWN -	REVISED -			0330	2009-133 I	COOK	28	21	
	PLOT SCALE = 1/8" = 1' IN.	CHECKED -	REVISED -			CONTRACT NO. 60H89					
	PLOT DATE = 4/28/2010	DATE -	REVISED -			ILLINOIS FED. AID PROJECT					

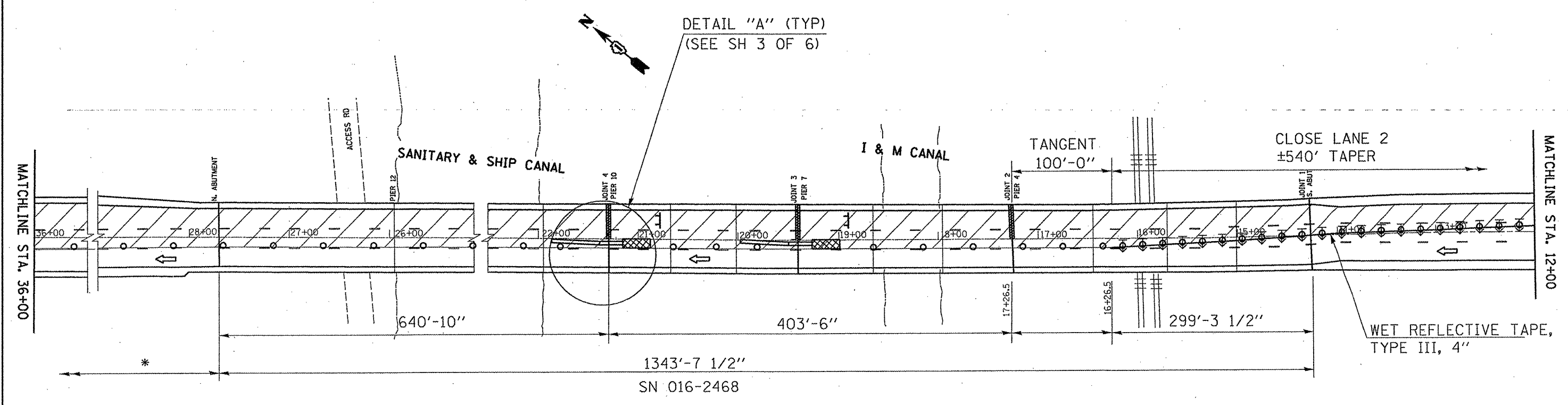
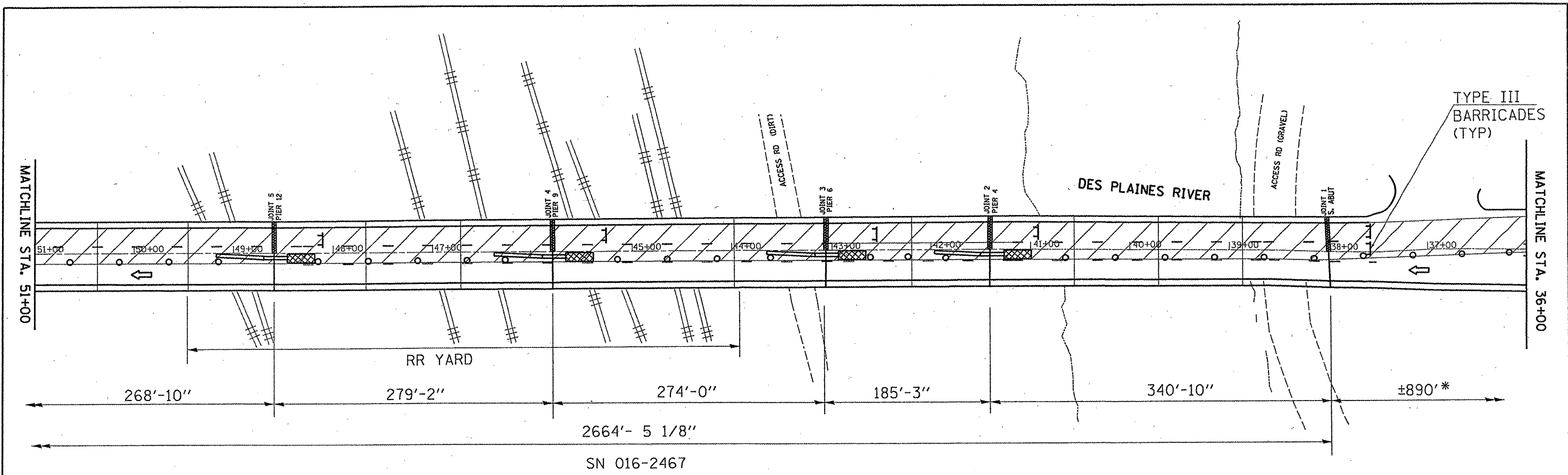

FILE NAME = c:\p\work\KVP\DOT\GORENGAUTAB\8175993	USER NAME = gorengautab 0125218-shr-plan.dgn	DESIGNED - DRAWN -	REVISED - REVISED -	STATE OF ILLINOIS DEPARTMENT OF TRANSPORTATION	US 1220/45 (LAGRANGE) NB TRAFFIC CONTROL PLAN STAGE 1	F.A.P. RTE. 0330	SECTION 2009-133 1	COUNTY COOK	TOTAL SHEETS 28	SHEET NO. 22		
	PLOT SCALE = 1/8" = 1' IN. PLOT DATE = 4/28/2010	CHECKED - DATE -	REVISED - REVISED -			SCALE:	SHEET NO. 2 OF 6 SHEETS	STA. TO STA.	CONTRACT NO. 60H89 ILLINOIS FED. AID PROJECT			

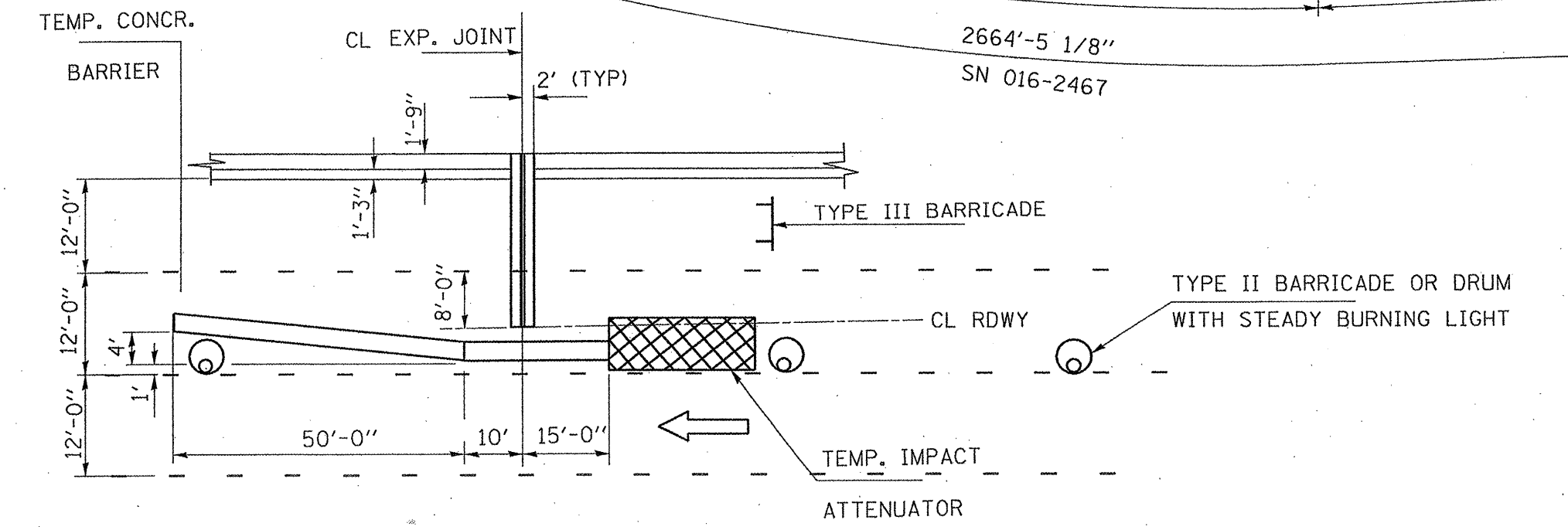
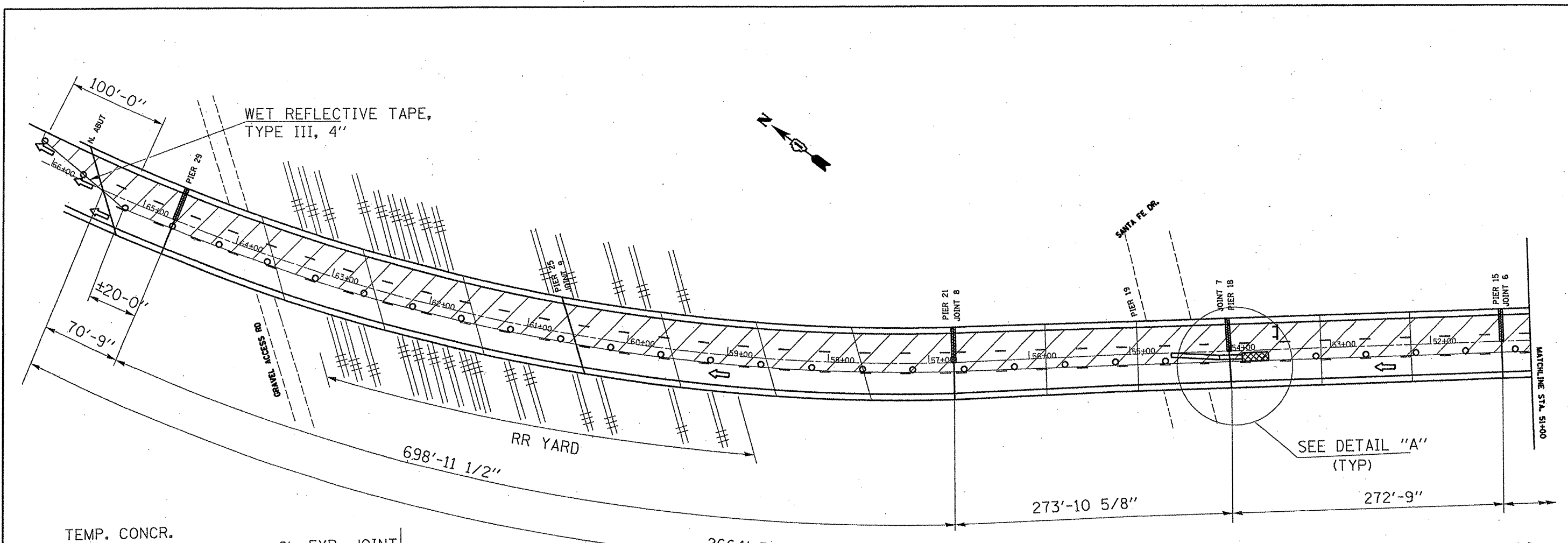

DETAIL A

FILE NAME: ch:\pw_work\PWIDOT\GORENGAUTAB\	USER_NAME= gorenautab 01759938D125210-shr-plan.dwg	DESIGNED - DRAWN - CHECKED - DATE -	REVISED - REVISED - REVISED - REVISED -	STATE OF ILLINOIS DEPARTMENT OF TRANSPORTATION	US 12/20/45 (LAGRANGE) NB TRAFFIC CONTROL PLAN STAGE 1		F.A.P. RTE. 0330	SECTION 2009-133 I	COUNTY COOK	TOTAL SHEETS 28	SHEET NO. 23	
	PLOT SCALE 1/32" = 1' / IN. PLOT DATE= 4/20/2010							CONTRACT NO. 60489		ILLINOIS FED. AID PROJECT		
	SCALE:					SHEET NO. 3 OF 6 SHEETS STA.		TO STA.				

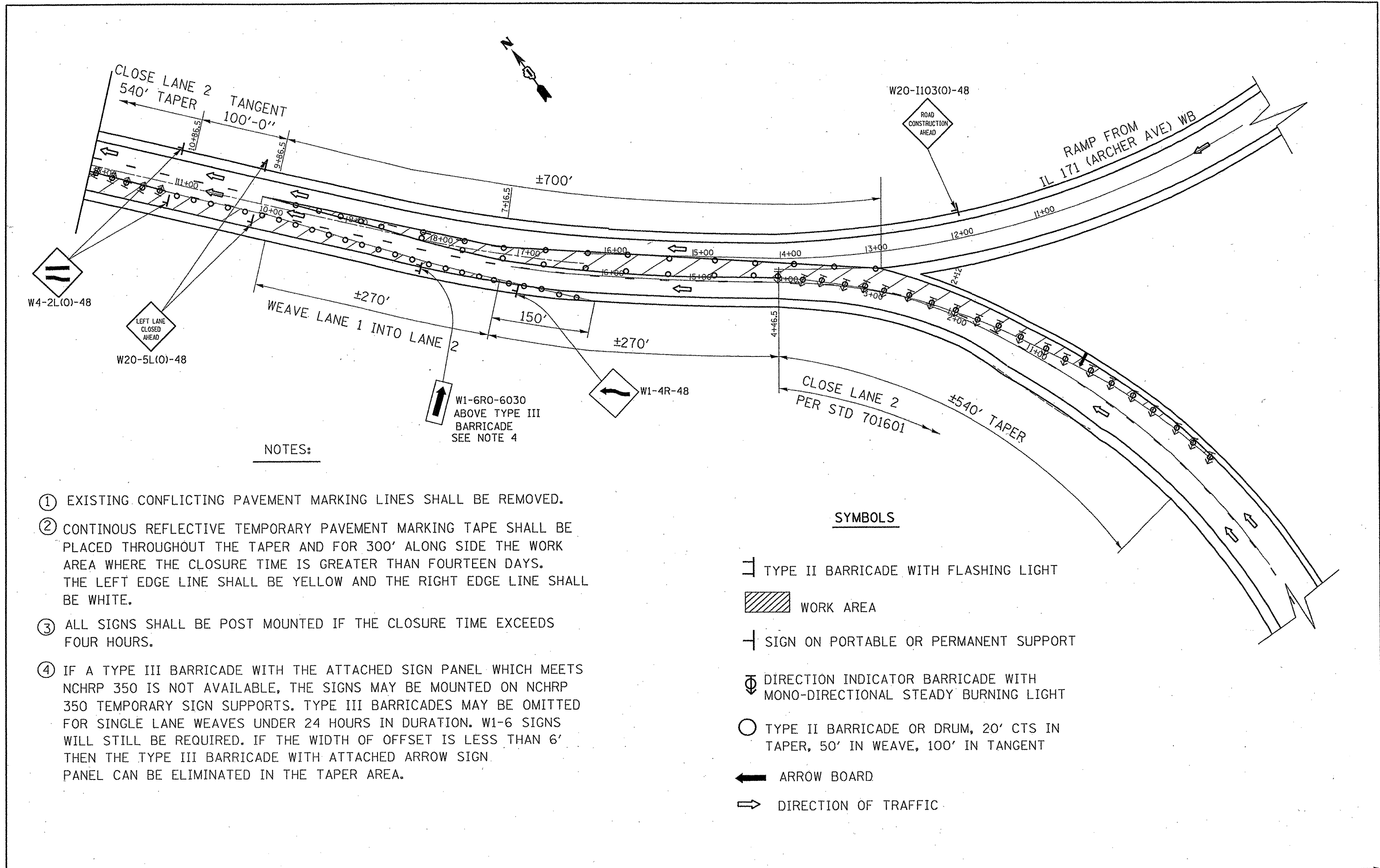

NOTES:

- ① EXISTING CONFLICTING PAVEMENT MARKING LINES SHALL BE REMOVED.
- ② CONTINUOUS REFLECTIVE TEMPORARY PAVEMENT MARKING TAPE SHALL BE PLACED THROUGHOUT THE TAPER AND FOR 300' ALONG SIDE THE WORK AREA WHERE THE CLOSURE TIME IS GREATER THAN FOURTEEN DAYS. THE LEFT EDGE LINE SHALL BE YELLOW AND THE RIGHT EDGE LINE SHALL BE WHITE.
- ③ ALL SIGNS SHALL BE POST MOUNTED IF THE CLOSURE TIME EXCEEDS FOUR HOURS.
- ④ IF A TYPE III BARRICADE WITH THE ATTACHED SIGN PANEL WHICH MEETS NCHRP 350 IS NOT AVAILABLE, THE SIGNS MAY BE MOUNTED ON NCHRP 350 TEMPORARY SIGN SUPPORTS. TYPE III BARRICADES MAY BE OMITTED FOR SINGLE LANE WEAVES UNDER 24 HOURS IN DURATION. W1-6 SIGNS WILL STILL BE REQUIRED. IF THE WIDTH OF OFFSET IS LESS THAN 6' THEN THE TYPE III BARRICADE WITH ATTACHED ARROW SIGN PANEL CAN BE ELIMINATED IN THE TAPER AREA.

SYMBOLS

- ⊥ TYPE II BARRICADE WITH FLASHING LIGHT
- ▨ WORK AREA
- ⊥ SIGN ON PORTABLE OR PERMANENT SUPPORT
- ⊕ DIRECTION INDICATOR BARRICADE WITH MONO-DIRECTIONAL STEADY BURNING LIGHT
- TYPE II BARRICADE OR DRUM, 20' CTS IN TAPER, 50' IN WEAVE, 100' IN TANGENT
- ← ARROW BOARD
- ⇒ DIRECTION OF TRAFFIC

FILE NAME =	USER NAME = gorengautob	DESIGNED -	REVISED -
et:\pwwork\VPWIDOT\GORENGAUTAB\d0175993	D125218-sht-plan.dgn	DRAWN -	REVISED -
	PLOT SCALE = 1/8" = 1' / IN.	CHECKED -	REVISED -
	PLOT DATE = 4/20/2010	DATE -	REVISED -

**STATE OF ILLINOIS
DEPARTMENT OF TRANSPORTATION**

**US 12/2045 (LAGRANGE) NB
TRAFFIC CONTROL PLAN
STAGE 2**

SCALE: SHEET NO. 4 OF 6 SHEETS STA. TO STA.

F.A.P. RTE. 0330	SECTION 2009-133 I	COUNTY COOK	TOTAL SHEETS 28	SHEET NO. 24
CONTRACT NO. 60H89			ILLINOIS FED. AID PROJECT	

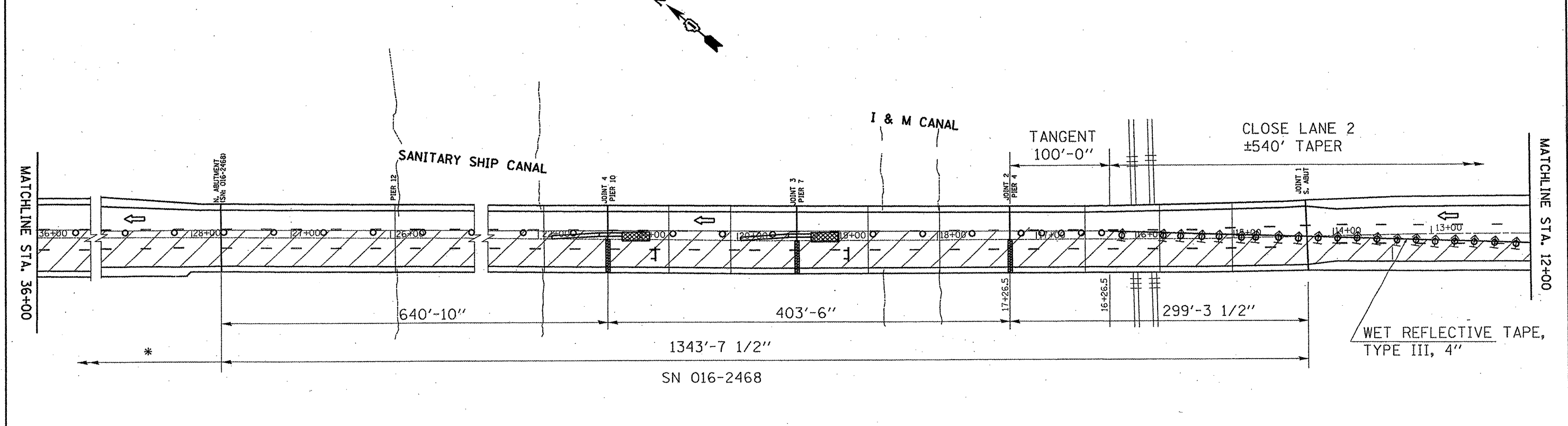
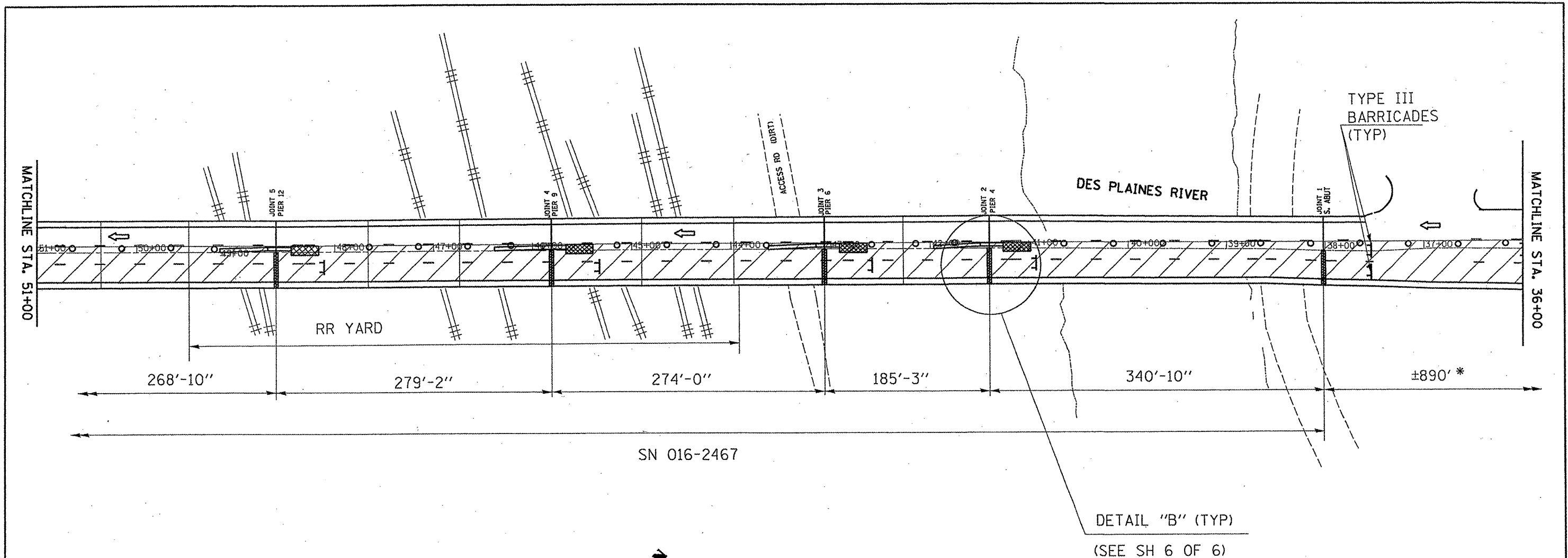

FILE NAME =	USER NAME = gorengautob	DESIGNED -	REVISED -	STATE OF ILLINOIS DEPARTMENT OF TRANSPORTATION	US 12/2045 (LAGRANGE) NB TRAFFIC CONTROL PLAN STAGE 2	F.A.P RTE. 0330	SECTION 2009-133 I	COUNTY COOK	TOTAL SHEETS 28	SHEET NO. 25		
os:\pwwork\PW\DOT\GORENGAUTOB\J0175993	D125210-ah-t-plen.dgn	DRAWN -	REVISED -			SCALE:	SHEET NO. 5 OF 6 SHEETS	STA.	TO STA.	CONTRACT NO. 60H89		
	PLOT SCALE = 1/32" = 1' IN.	CHECKED -	REVISED -			ILLINOIS FED. AID PROJECT						
	PLOT DATE = 4/28/2010	DATE -	REVISED -									

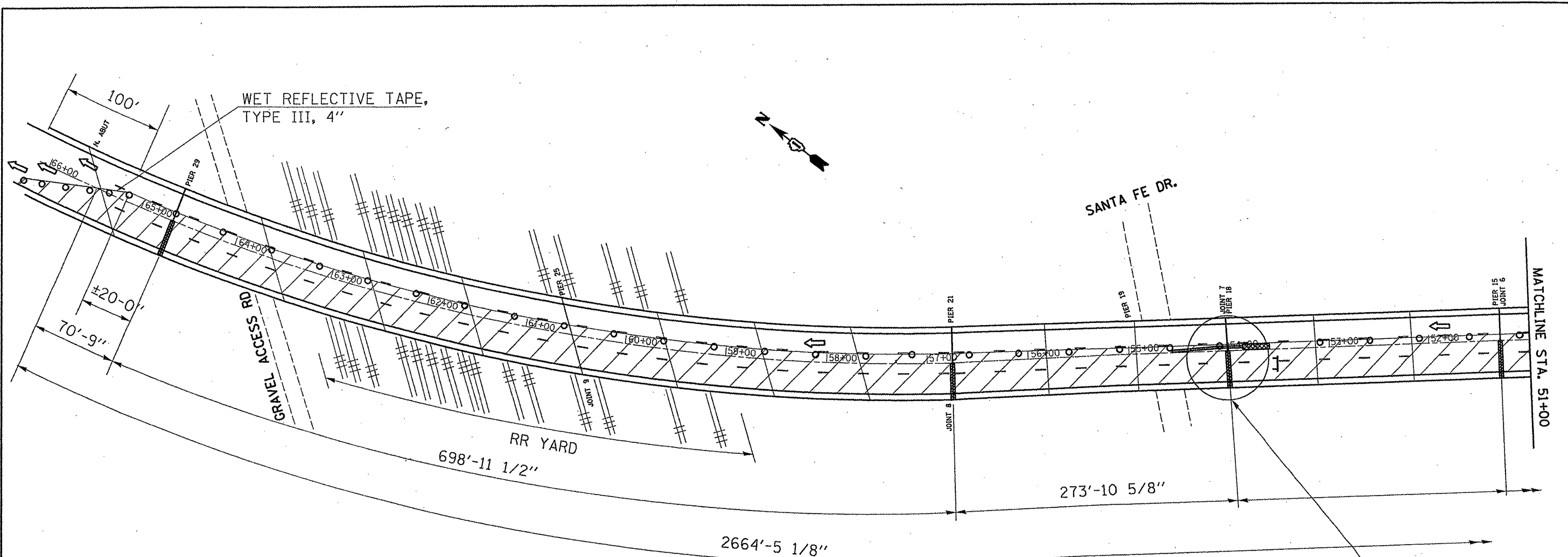

SN 016-2467

SEE DETAIL "B"

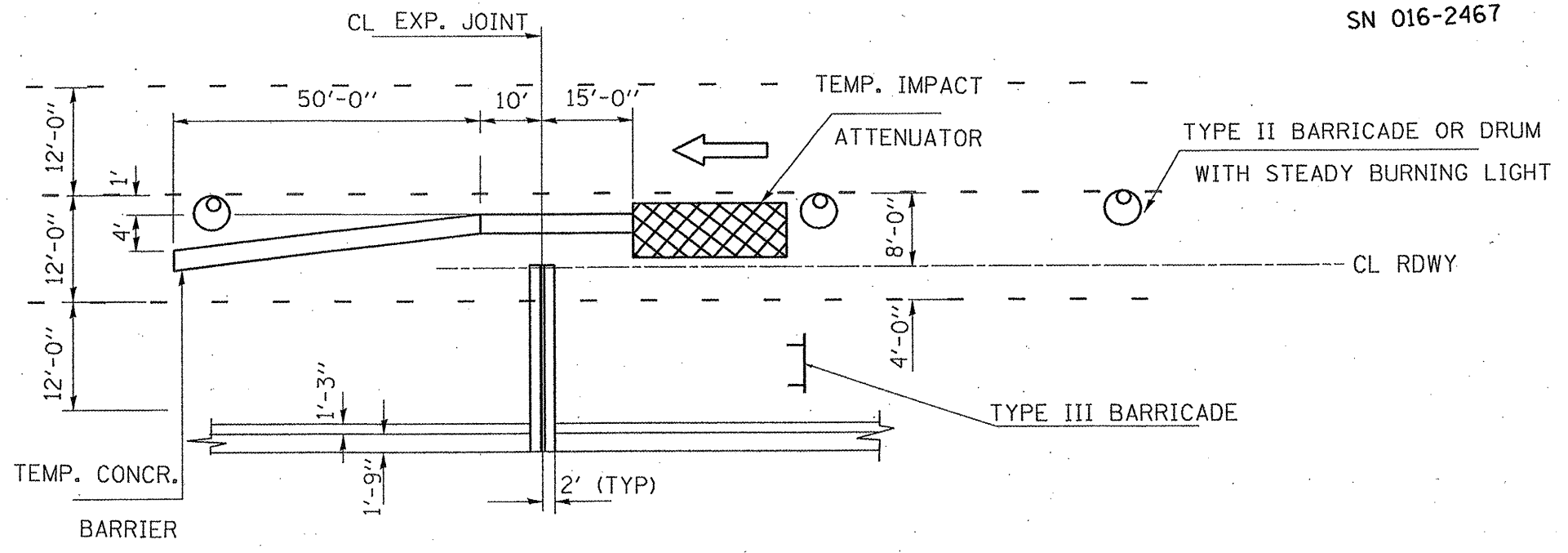

DETAIL B

FILE NAME =	USER NAME = gorengautob	DESIGNED -	REVISED -
ca\p\work\K\FWIDOT\GORENGAUTAB\01759993	0125210-shr-plen.dgn	DRAWN -	REVISED -
	PLOT SCALE = 103.1218 "/td> <td>CHECKED -</td> <td>REVISED -</td>	CHECKED -	REVISED -
	PLOT DATE = 4/28/2010	DATE -	REVISED -

STATE OF ILLINOIS
DEPARTMENT OF TRANSPORTATION

US 12/20/45 (LAGRANGE) NB	
TRAFFIC CONTROL PLAN	
STAGE 2	
SCALE:	SHEET NO. 6 OF 6 SHEETS STA. TO STA.

F.A.P. RTE.	SECTION	COUNTY	TOTAL SHEETS	SHEET NO.
0330	2009-133 I	COOK	28	26
CONTRACT NO. 60409				
ILLINOIS FED. AID PROJECT				

F.A. R.T.E.	SECTION	COUNTY	TOTAL SHEETS	SHEET NO.
	0009-1357	COOK	28	27
STA.		TO STA.		
FED. ROAD DIST. NO.		ILLINOIS FED. AID PROJECT		

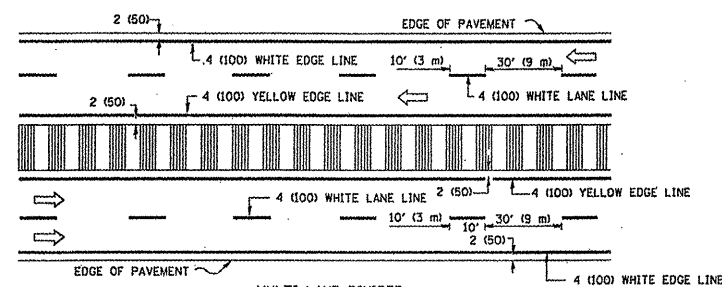
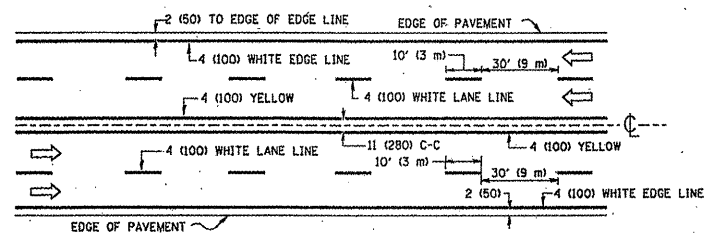
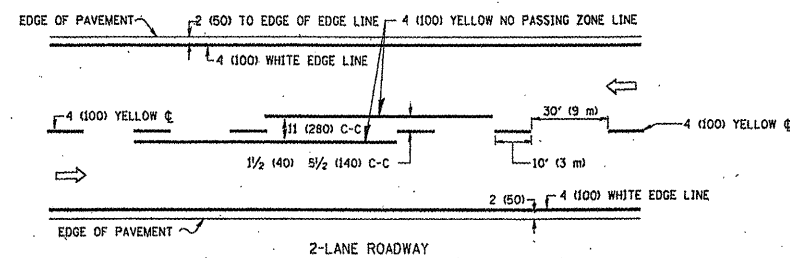

NOTE: MEDIANS WITH BARRIER CURBS DO NOT REQUIRE AN EDGE LINE

TYPICAL LANE AND EDGE LINE MARKING

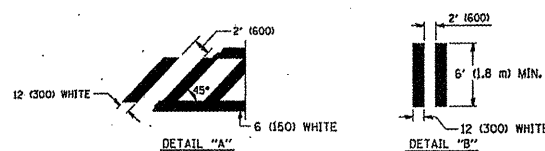
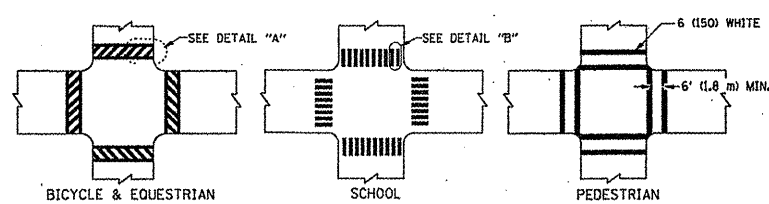

TYPICAL CROSSWALK MARKING

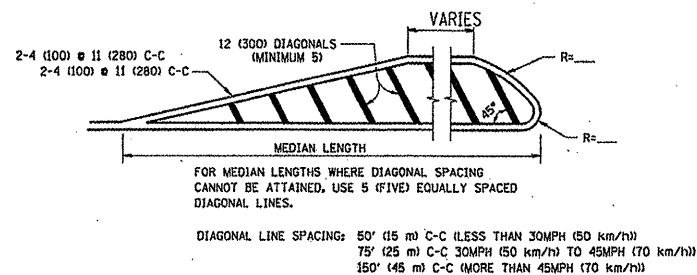
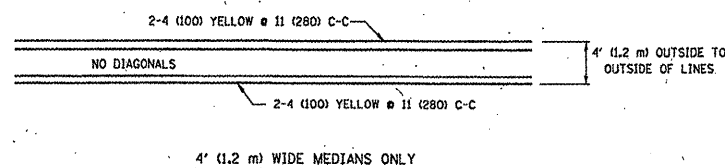

MEDIANS OVER 4' (1.2 m) WIDE

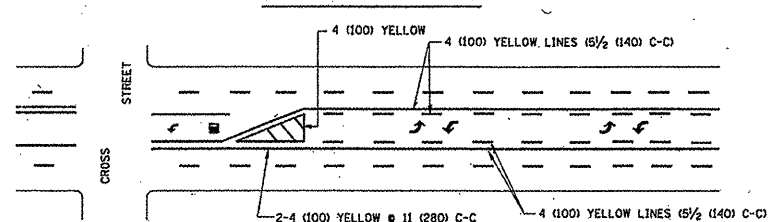

A MINIMUM OF TWO PAIRS OF TURN ARROWS SHALL BE USED, WHITE IN COLOR. ADDITIONAL PAIRS SHALL BE PLACED AT 200' (60 m) TO 300' (90 m) INTERVALS.

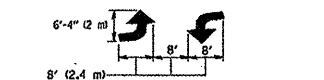

MEDIAN WITH TWO-WAY LEFT TURN LANE

TYPICAL PAINTED MEDIAN MARKING

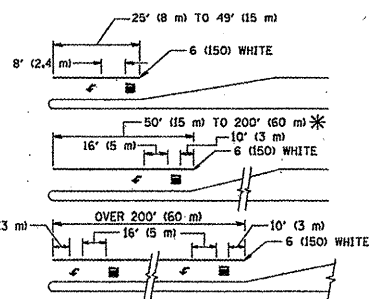

FULL SIZE LETTERS 8' (2.4 m) AND ARROWS SHALL BE USED. AREA = 15.6 SQ. FT. (1.5 m²) AREA = 20.8 SQ. FT. (1.9 m²)

* TURN LANES IN EXCESS OF 400' (120 m) IN LENGTH MAY HAVE AN ADDITIONAL SET OF ARROW - "ONLY" INSTALLED MIDWAY BETWEEN THE OTHER TWO SETS OF ARROW - "ONLY".

TYPICAL LEFT (OR RIGHT) TURN LANE

TYPICAL TURN LANE MARKING

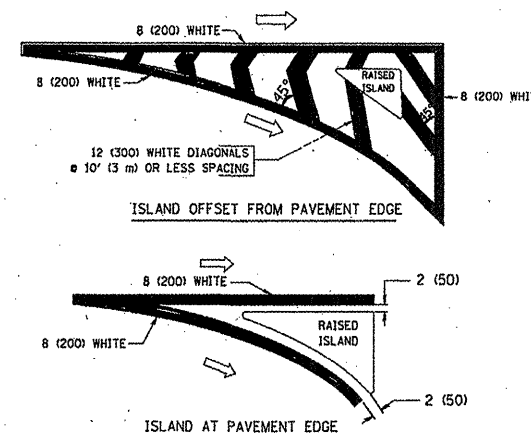

TYPICAL ISLAND MARKING

TYPE OF MARKING	WIDTH OF LINE	PATTERN	COLOR	SPACING / REMARKS
CENTERLINE ON 2 LANE PAVEMENT	4 (100)	SKIP-DASH	YELLOW	10' (3 m) LINE WITH 30' (9 m) SPACE
CENTERLINE ON MULTI-LANE UNDIVIDED PAVEMENT	2 @ 4 (100)	SOLID	YELLOW	11 (280) C-C
NO PASSING ZONE LINES FOR ONE DIRECTION FOR BOTH DIRECTIONS	4 (100) 2 @ 4 (100)	SOLID SOLID	YELLOW YELLOW	5/2 (140) C-C FROM SKIP-DASH CENTERLINE 11 (280) C-C OMIT SKIP-DASH CENTERLINE BETWEEN
LANE LINES	4 (100) 5 (125) ON FREEWAYS	SKIP-DASH SKIP-DASH	WHITE WHITE	10' (3 m) LINE WITH 30' (9 m) SPACE
DOTTED LINES (EXTENSIONS OF CENTER, LANE OR TURN LANE MARKINGS)	SAME AS LINE BEING EXTENDED	SKIP-DASH	SAME AS LINE BEING EXTENDED	2' (600) LINE WITH 6' (1.8 m) SPACE
EDGE LINES	4 (100)	SOLID	YELLOW-LEFT WHITE-RIGHT	OUTLINE MOUNTABLE MEDIANS IN YELLOW; EDGE LINES ARE NOT USED NEXT TO BARRIER CURB
TURN LANE MARKINGS	6 (150) LINE; FULL SIZE LETTERS & SYMBOLS @ (2.4m)	SOLID	WHITE	SEE TYPICAL TURN LANE MARKING DETAIL
TWO WAY LEFT TURN MARKING	2 @ 4 (100) EACH DIRECTION 8' (2.4m) LEFT ARROW	SKIP-DASH AND SOLID IN PAIRS	YELLOW WHITE	10' (3 m) LINE WITH 30' (9 m) SPACE FOR SKIP-DASH 5/2 (140) C-C BETWEEN SOLID LINE AND SKIP-DASH LINE SEE TYPICAL TWO-WAY LEFT TURN MARKING DETAIL
CROSSWALK LINES (PEDESTRIAN & BIKE & EQUESTRIAN) B. LONGITUDINAL BARS (SCHOOL)	2 @ 6 (150) 12 (300) @ 45° 12 (300) @ 90°	SOLID SOLID SOLID	WHITE WHITE WHITE	NOT LESS THAN 6' (1.8 m) APART 2' (600) APART 2' (600) APART SEE TYPICAL CROSSWALK MARKING DETAILS.
STOP LINES	24 (600)	SOLID	WHITE	PLACE 4' (1.2 m) IN ADVANCE OF AND PARALLEL TO CROSSWALK, IF PRESENT. OTHERWISE, PLACE AT DESIRED STOPPING POINT, PARALLEL TO CROSSROAD CENTERLINE, WHERE POSSIBLE.
PAINTED MEDIANS	2 @ 4 (100) WITH 12 (300) DIAGONALS @ 45° NO DIAGONALS USED FOR 4' (1.2 m) WIDE MEDIANS	SOLID	YELLOW; TWO WAY TRAFFIC WHITE; ONE WAY TRAFFIC	11 (280) C-C FOR THE DOUBLE LINE SEE TYPICAL PAINTED MEDIAN MARKING.
GORE MARKING AND CHANNELIZING LINES	8 (200) WITH 12 (300) DIAGONALS @ 45°	SOLID	WHITE	DIAGONALS: 15' (4.5 m) C-C (LESS THAN 30MPH (50 km/h)) 20' (6 m) C-C 30MPH (50 km/h) TO 45MPH (70 km/h) 30' (9 m) C-C (OVER 45MPH (70 km/h))
RAILROAD CROSSING	24 (600) TRANSVERSE LINES; "RR" 15' (4.5 m) LETTERS; 16 (400) LINE FOR "X"	SOLID	WHITE	SEE STATE STANDARD 780001 AREA OF: "R"=3.6 SQ. FT. (0.33 m ²) EACH "X"=84.0 SQ. FT. (7.8 m ²)
SHOULDER DIAGONALS	12 (300) @ 45°	SOLID	WHITE - RIGHT YELLOW - LEFT	50' (15 m) C-C (LESS THAN 30MPH (50 km/h)) 75' (25 m) C-C (30 MPH (50 km/h) TO 45MPH (70 km/h)) 150' (45 m) C-C (OVER 45MPH (70 km/h))

FOR FURTHER DETAILS ON PAVEMENT MARKING REFER TO STANDARD SPECIFICATIONS FOR ROAD AND BRIDGE CONSTRUCTION AND STATE STANDARD 780001.

All dimensions are in inches (millimeters) unless otherwise shown.

REVISIONS	
NAME	DATE
EVERS	03-19-90
T. RAMMACHER	10-27-94
C. JUCIUS	09-09-09

ILLINOIS DEPARTMENT OF TRANSPORTATION

DISTRICT ONE
TYPICAL PAVEMENT
MARKINGS

SCALE: NONE

DRAWN BY CADD

CHECKED BY

TC-13

F.A. RTE.	SECTION	COUNTY	TOTAL SHEETS	SHEET NO.
	2000-1331	COOK	28	28
STA.		TO STA.		
FED. ROAD DIST. NO.		ILLINOIS FED. AID PROJECT		

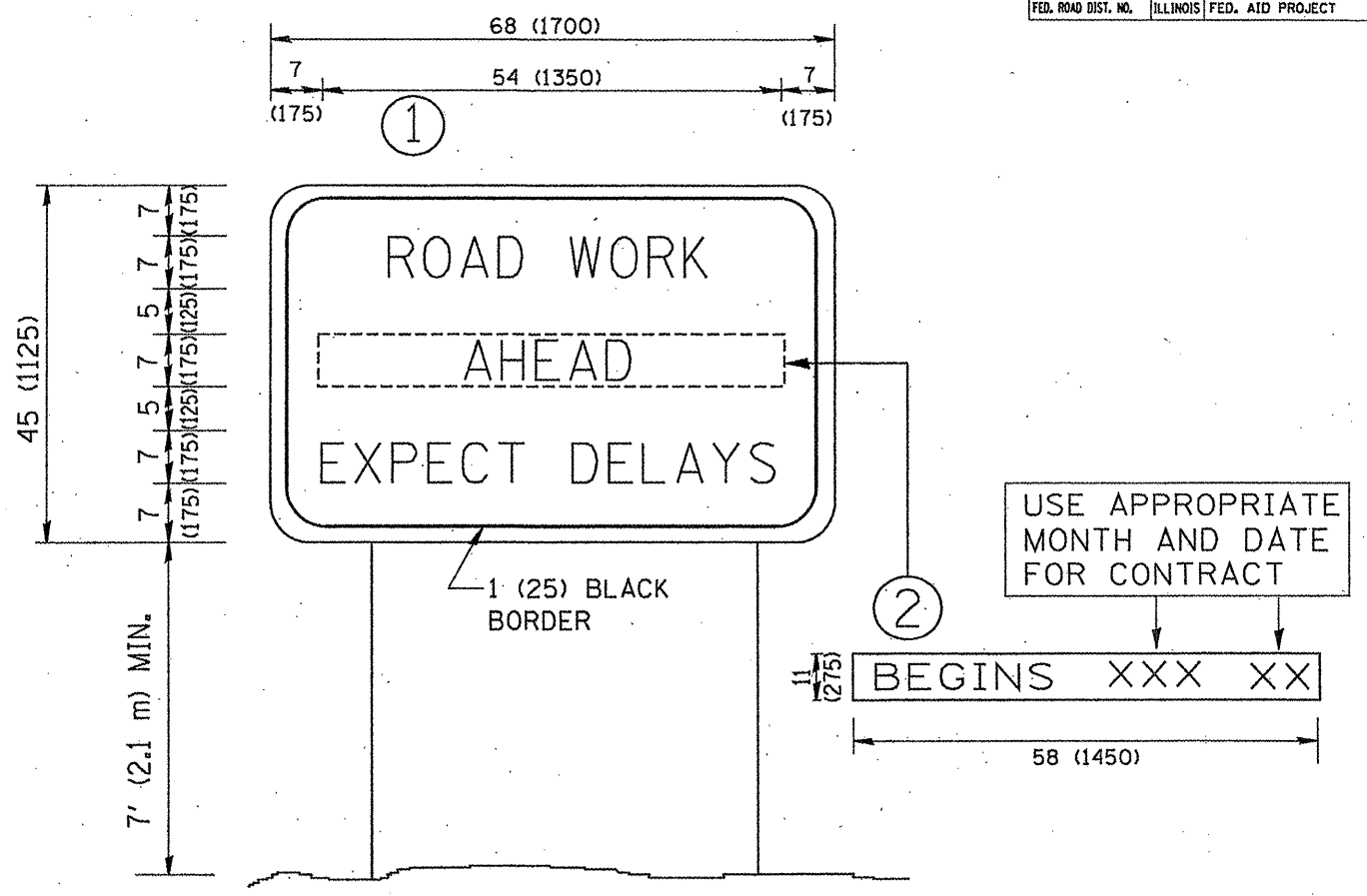

NOTES:

1. USE BLACK LETTERING ON ORANGE BACKGROUND.
2. ERECT SIGNS IN ADVANCE OF THE LOCATION FOR THE "ROAD CONSTRUCTION AHEAD" SIGN AT LOCATIONS AS DIRECTED BY THE ENGINEER.
3. ERECT SIGN ① WITH INSTALLED PANEL ② ONE WEEK PRIOR TO THE START OF CONSTRUCTION.
4. REMOVE PANEL ② SOON AFTER THE START OF CONSTRUCTION.
5. SEE SPECIAL PROVISION FOR "TEMPORARY INFORMATION SIGNING" FOR ADDITIONAL INFORMATION.
6. ONE SIGN ASSEMBLY EQUALS 25.70 SQ. FT. (2.3 SQ. M.)
7. SHALL BE PAID FOR AS TEMPORARY INFORMATION SIGNING.

ALL DIMENSIONS ARE IN INCHES (MILLIMETERS) UNLESS OTHERWISE SHOWN.

REVISIONS	
NAME	DATE
R. MIRS	9-15-97
R. MIRS	12-11-97
T. RAMMACHER	2-2-99
C. JUCIUS	1-31-07

ILLINOIS DEPARTMENT OF TRANSPORTATION

ARTERIAL ROAD INFORMATION SIGN

SCALE: NONE

DRAWN BY DESIGN
CHECKED BY
TC22