

FOR INDEX OF SHEETS, SEE SHEET NO. 2  
 FOR LIST OF HIGHWAY STANDARDS, SHEET SHEET NO. 2  
 FOR SUMMARY OF QUANTITIES, SEE SHEET NO. 3-7

STATE OF ILLINOIS  
 DEPARTMENT OF TRANSPORTATION  
**PROPOSED  
 HIGHWAY PLANS**

FAI ROUTE 55 (I 55)  
 SECTION (57-1, 57-2)BDS  
 PROJECT NHPP-DM2U(328)  
 BRIDGE DECK OVERLAY  
 MCLEAN COUNTY

C-95-025-19

N OF LEXINGTON TO LIVINGSTON CO LINE

SN 057-0178 SB  
 SN 057-0179 NB  
 F.A.I. 55 (I-55) STA. 411+30  
 OVER TP&W RAILROAD  
 PROPOSED STRUCTURE REPAIRS

SN 057-0152 SB  
 SN 057-0153 NB  
 F.A.I. 55 (I-55) STA. 398+57  
 OVER US 24  
 PROPOSED STRUCTURE REPAIRS

STATION EQUATION  
 785+00.20 (BK) =  
 100+00.00 (AH)

SN 057-0173 SB  
 SN 057-0174 NB  
 F.A.I. 55 (I-55) STA. 781+50  
 OVER TURKEY CREEK  
 PROPOSED STRUCTURE REPAIRS

SN 057-0182 SB  
 SN 057-0183 NB  
 F.A.I. 55 (I-55) STA. 711+75  
 OVER TURKEY CREEK  
 PROPOSED STRUCTURE REPAIRS

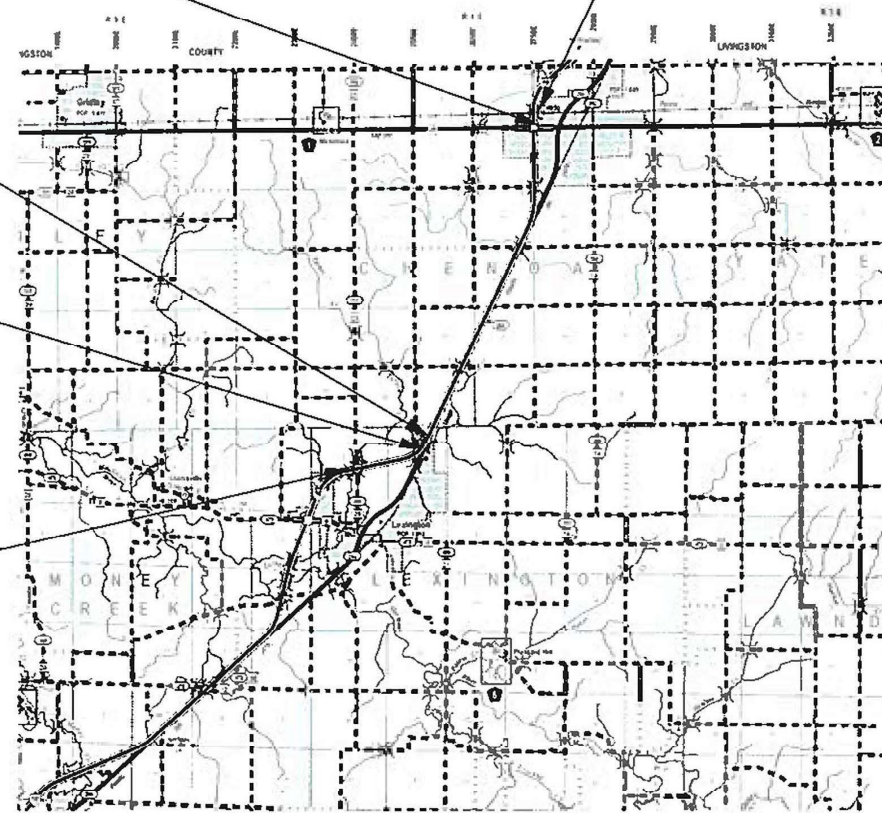

LOCATION MAP  
 NOT TO SCALE

GROSS LENGTH = 52,607.96 FT. = 9.96 MILE  
 NET LENGTH = FT. = MILE

F.A.I. RTE.	SECTION	COUNTY	TOTAL SHEETS	SHEET NO.
55	(57-1, 57-2)BDS	MCLEAN	89	1
		ILLINOIS	CONTRACT NO. 70D64	

D-95-020-19

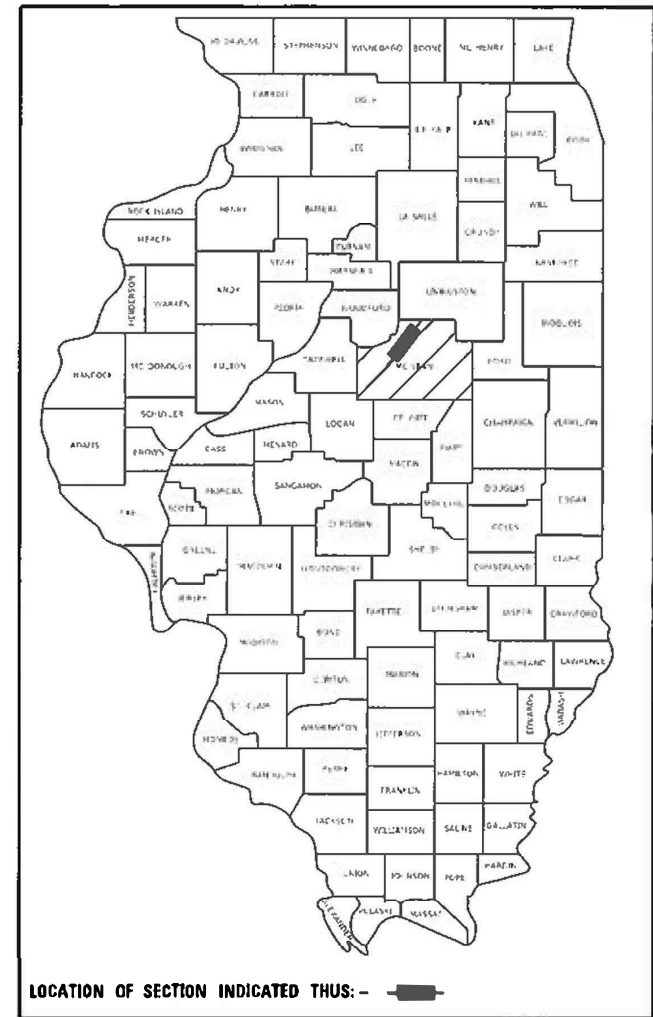

LOCATION OF SECTION INDICATED THUS: - [Symbol]

**FUNCTIONAL CLASSIFICATION**

PRINCIPAL ARTERIAL (INTERSTATE)		
I-55 S. OF FAS 473	I-55 - FAS 473	I-55 - US 24 TO LIVINGSTON COUNTY LINE
2019 ADT = 24,300	TO US 24 2019 ADT = 26,600	2019 ADT = 24,400
P.V. = 72.1%	P.V. = 74.2%	P.V. = 74.9%
S.U. = 4.4%	S.U. = 4.4%	S.U. = 3.4%
M.U. = 23.5%	M.U. = 21.4%	M.U. = 21.7%

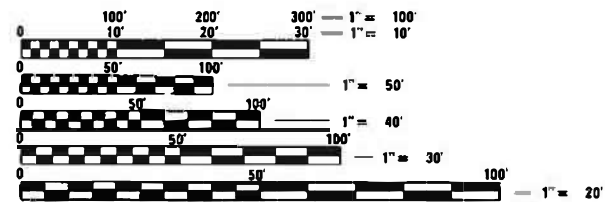

FULL SIZE PLANS HAVE BEEN PREPARED USING STANDARD ENGINEERING SCALES. REDUCED SIZED PLANS WILL NOT CONFORM TO STANDARD SCALES. IN MAKING MEASUREMENTS ON REDUCED PLANS, THE ABOVE SCALES MAY BE USED.

J.U.L.I.E.  
 JOINT UTILITY LOCATION INFORMATION FOR EXCAVATORS  
 1-800-892-0123  
 OR 811

TOWNSHIPS: MONEY CREEK, LEXINGTON, CHENOA  
 PROJECT ENGINEER JASON STULTS, P.E.  
 PROJECT MANAGER JASON GOBLE, P.E.  
 (217) 465-4181  
 CONTRACT NO. 70D64



SHEETS 1-20, 87-88  
 ROBERT HANFLAND, PE  
 STATE OF ILLINOIS NO. 062-064104  
 EXPIRES 11-30-2021

STATE OF ILLINOIS  
 DEPARTMENT OF TRANSPORTATION

SUBMITTED 10/22 20 21  
*Kensil A. Samethson*  
 REGIONAL ENGINEER

December 10, 2021  
*[Signature]*  
 ENGINEER OF DESIGN AND ENVIRONMENT

December 10, 2021  
*[Signature]*  
 DIRECTOR OF HIGHWAYS PROJECT IMPLEMENTATION

**PRINTED BY THE AUTHORITY  
 OF THE STATE OF ILLINOIS**

## INDEX OF SHEETS

1	COVER SHEET
2	LIST OF STANDARDS, INDEX OF SHEETS, COMMITMENTS, & GENERAL NOTES
3-7	SUMMARY OF QUANTITIES
8	TYPICAL SECTIONS
9-11	SCHEDULE OF QUANTITIES
12-13	ROADWAY PLAN SHEETS
14-17	TEMPORARY CONCRETE BARRIER LAYOUT
18-19	MAINTENANCE OF TRAFFIC WIDTH RESTRICTION SIGNING DETAILS
20	DETOUR SIGNING PLAN
21-46	STRUCTURE REPAIR DETAILS - S.N. 057-0152 & S.N. 057-0153
47-57	STRUCTURE REPAIR DETAILS - S.N. 057-0173 & S.N. 057-0174
58-70	STRUCTURE REPAIR DETAILS - S.N. 057-0178 & S.N. 057-0179
71-83	STRUCTURE REPAIR DETAILS - S.N. 057-0182 & S.N. 057-0183
84	DETAIL OF TEMPORARY RUMBLE STRIPS (SPECIAL)
85	DETAIL OF PAVEMENT MARKING (INTERSTATE & MULTI-LANE APPLICATIONS D5 DETAIL 7800BBBB)
86	DETAIL OF WIDTH RESTRICTION SIGNING D5 DETAIL X7200201
87-88	CROSS SECTIONS

## GENERAL NOTES

G.N. -105.09A  
ALL ELEVATIONS SHOWN IN THE PLANS ARE BASED ON NORTH AMERICAN VERTICAL DATUM OF 1988. (NAVD 88)

G.N. -107.12  
THE NAME, ADDRESS AND TELEPHONE NUMBER OF THE LOCAL RAILROAD CONTACT IS:  
MR. JOSH THOMOS  
ROADMASTER TOLEDO, PEORIA AND WESTERN RAILWAY  
1990 EAST WASHINGTON STREET  
EAST PEORIA, IL 61611  
(309) 303-9404

SPECIAL ATTENTION IS CALLED TO ARTICLE 107.12 REGARDING RAILROAD FLAGGERS. THE NAME, ADDRESS AND TELEPHONE NUMBER OF THE RAILROAD FLAGGER CONTACT IS:

G.N. -406H

### MIXTURE REQUIREMENTS

THE FOLLOWING MIXTURE REQUIREMENTS ARE APPLICABLE FOR THIS PROJECT:

Location Mixture Use	FAI 55 Mainline Shoulder Binder (Bottom 12.0")	FAI 55 Mainline Shoulder Surface (Top 2.0")	FAI 55 Stabilized Subbase
AC/PG	PG 64-22	PG 64-22	PG 64-22
Design Air Voids	4.0% @ Ndes=90	4.0% @ Ndes=90	4.0% @ Ndes=50
Mix Comp(Gradation)	IL 19.0	IL 9.5	IL 19.0
Friction Aggregate	N.A.	Mix D	N.A.
Mixture Weight	112	112	112
Quality Management Program	QC/QA	QC/QA	QC/QA
Sublot Size	N.A.	N.A.	N.A.
Material Transfer Device (Required ?)	No	No	No

## HIGHWAY STANDARDS

000001-08	STANDARD SYMBOLS, ABBREVIATIONS AND PATTERNS
001001-02	AREAS OF REINFORCEMENT BARS
001006	DECIMAL OF AN INCH AND OF A FOOT
421001-03	BAR REINFORCEMENT FOR CRC PAVEMENT
421201-07	24' CRC PAVEMENT (WITH LUG SYSTEM)
482001-02	HMA SHOULDER ADJACENT TO FLEXIBLE PAVEMENT
542401-04	METAL FLARED END SECTION FOR PIPE CULVERTS
642001-03	SHOULDER RUMBLE STRIPS, 16 IN.
701101-05	OFF-ROAD OPERATIONS, MULTILANE, 15' TO 24" FROM PAVEMENT EDGE
701106-02	OFF-ROAD OPERATIONS, MULTILANE, MORE THAN 15' (4.5 M) AWAY
701400-11	APPROACH TO LANE CLOSURE, FREEWAY/EXPRESSWAY
701402-12	LANE CLOSURE, FREEWAY/EXPRESSWAY, WITH BARRIER
701411-09	LANE CLOSURE, MULTILANE, AT ENTRANCE OR EXIT RAMP, FOR SPEEDS > 45 MPH
701428-01	TRAFFIC CONTROL, SETUP AND REMOVAL, FREEWAY/EXPRESSWAY
701451-05	RAMP CLOSURE FREEWAY/EXPRESSWAY
701601-09	URBAN LANE CLOSURE MULTILANE, 1W OR 2W WITH NONTRAVERSABLE MEDIAN
701901-08	TRAFFIC CONTROL DEVICES
704001-08	TEMPORARY CONCRETE BARRIER
780001-05	TYPICAL PAVEMENT MARKINGS
701426--09	LANE CLOSURE, MULTILANE, INTERMITTENT OR MOVING OPER., FOR SPEEDS >= 45 MPH

G.N. -440B

THE EXISTING TIE BARS BETWEEN THE EXISTING PAVEMENT AND EXISTING MEDIANS, GUTTERS AND/OR COMBINATION CURB AND GUTTERS THAT ARE FOUND SUITABLE FOR REUSE SHALL BE CLEANED, STRAIGHTENED AND INCORPORATED INTO THE NEW CONSTRUCTION. ANY EXISTING TIE BARS THAT ARE FOUND UNSUITABLE TO BE INCORPORATED INTO THE PROPOSED CONSTRUCTION DUE TO EXCESSIVE RUSTING OR DISTRESS SHALL BE REMOVED FLUSH WITH THE FACE OF THE EXISTING CONCRETE AND DISPOSED OF OUTSIDE THE LIMITS OF THE RIGHT-OF-WAY IN ACCORDANCE WITH ARTICLE 202.03 OF THE STANDARD SPECIFICATIONS.

THIS WORK WILL NOT BE PAID FOR SEPARATELY BUT SHALL BE CONSIDERED INCLUDED IN THE VARIOUS REMOVAL PAY ITEMS AND NO ADDITIONAL COMPENSATION WILL BE ALLOWED.

G.N. - 703A

SHORT TERM PAVEMENT MARKING SHALL BE APPLIED TO THE PAVEMENT AFTER ANY OF THE FOLLOWING: COLD MILLING AND/OR PLACING BITUMINOUS MATERIALS (TACK COAT), LEVELING BINDER (MACHINE METHOD), BINDER AND SURFACE COURSES. SHORT TERM PAVEMENT MARKING PLACED ON THE SURFACE SHALL COINCIDE WITH THE FINAL PAVEMENT STRIPING. SHORT TERM PAVEMENT MARKING PLACED PRIOR TO THE SURFACE SHALL COINCIDE WITH THE EXISTING PAVEMENT MARKINGS. USE 4 FEET PER 40 FEET (OR 10% PER STATION).

G.N. - 781

THE FINAL PAVEMENT MARKINGS SHALL BE IN PLACE PRIOR TO PLACING THE RAISED REFLECTIVE PAVEMENT MARKERS.

SYNTHETIC FIBERS SHALL BE INCLUDED IN THE BRIDGE DECK CONCRETE OVERLAY SPECIFIED. SEE SPECIAL PROVISIONS

## COMMITMENTS

THERE ARE NO COMMITMENTS

STATE OF ILLINOIS  
DEPARTMENT OF TRANSPORTATION

INDEX OF SHEETS, LIST OF STANDARDS,  
& COMMITMENTS

SCALE: N.T.S. SHEET 1 OF 1 SHEETS STA. TO STA.

F.A.I. RTE.	SECTION	COUNTY	TOTAL SHEETS	SHEET NO.
55	(57-1,57-2)BDS	MCLEAN	88	2
CONTRACT NO. 70D64				
ILLINOIS FED. AID PROJECT				

REV. 12/15/21 REV. 12/13/21

USER NAME = rhanfland	DESIGNED - WMK	REVISED -
DRAWN - DMM	REVISED -	
PLOT SCALE = 2.000' / in.	CHECKED - RLH	REVISED -
PLOT DATE = 12/8/2021	DATE - 12/8/2021	REVISED -

CODE NO.	ITEM	UNIT	MCLEAN CO.	MCLEAN CO.	MCLEAN CO.	MCLEAN CO.	MCLEAN CO.
			FAI 55 (1-55)	FAI 55 (1-55)	FAI 55 (1-55)	FAI 55 (1-55)	FAI 55 (1-55)
			RURAL INTERSTATE	RURAL INTERSTATE	RURAL INTERSTATE	RURAL INTERSTATE	RURAL INTERSTATE
			STRUCTURE NO.	STRUCTURE NO.	STRUCTURE NO.	STRUCTURE NO.	STRUCTURE NO.
			90% FED 10% STATE	90% FED 10% STATE	90% FED 10% STATE	90% FED 10% STATE	90% FED 10% STATE
			0059	057-0152	057-0173	057-0178	057-0182
			TOTAL	057-0153	057-0174	057-0179	057-0183
			QUANTITY	QUANTITY	QUANTITY	QUANTITY	QUANTITY
20200100	EARTH EXCAVATION	CU YD	248			248	
28100107	STONE RIPRAP, CLASS A4	SQ YD	405			405	
28200200	FILTER FABRIC	SQ YD	405			405	
31200500	STABILIZED SUBBASE - HOT-MIX ASPHALT, 4"	SQ YD	970		762		208
40600275	BITUMINOUS MATERIALS (PRIME COAT)	POUND	1,300		1,022		278
42100380	CONTINUOUSLY REINFORCED PORTLAND CEMENT CONCRETE PAVEMENT 14"	SQ YD	866		681		185
40800029	BITUMINOUS MATERIALS (TACK COAT)	POUND	3,323	415	1,224	810	874
42100615	PAVEMENT REINFORCEMENT	SQ YD	866		681		185
42101300	PROTECTIVE COAT	SQ YD	9,499	3,259	1,560	2,080	2,600
44000100	PAVEMENT REMOVAL	SQ YD	866		681		185
44000157	HOT-MIX ASPHALT SURFACE REMOVAL, 2"	SQ YD	6,240	922	1,813	1,810	1,695
44000300	CURB REMOVAL	FOOT	37		17		20
44004250	PAVED SHOULDER REMOVAL	SQ YD	578		454		124
48101498	AGGREGATE SHOULDERS, TYPE B 4"	SQ YD	217		170		47
48102100	AGGREGATE WEDGE SHOULDER, TYPE B	TON	95	16	29	26	24
48203053	HOT-MIX ASPHALT SHOULDERS, 14"	SQ YD	578		454		124

\* SPECIALTY ITEM

MODEL: Default  
FILE NAME: P:\Effingham\9454 - PTB 188 DOT D3 VAVWork Order #6\CaddSheet\0570912.dwg, 500.dgn



**CIVIL DESIGN, INC.**  
WBE / DBE  
EFFINGHAM, IL  
LICENSE #184.003222

USER NAME = abohnhoff	DESIGNED - WMK	REVISED -
PLOT SCALE = 2.0000' / in.	DRAWN - DMM	REVISED -
PLOT DATE = 10/22/2021	CHECKED - RLH	REVISED -
	DATE - 10/22/2021	REVISED -

**STATE OF ILLINOIS**  
**DEPARTMENT OF TRANSPORTATION**

**SUMMARY OF QUANTITIES**

SCALE: N.T.S. SHEET 1 OF 5 SHEETS STA. TO STA.

F.A.I. RTE.	SECTION	COUNTY	TOTAL SHEETS	SHEET NO.
55	(57-1,57-2)BDS	MCLEAN	88	3
CONTRACT NO. 70D64				

ILLINOIS FED. AID PROJECT



CODE NO.	ITEM	UNIT	MCLEAN CO.	MCLEAN CO.	MCLEAN CO.	MCLEAN CO.	MCLEAN CO.
			FAI 55 (I-55)	FAI 55 (I-55)	FAI 55 (I-55)	FAI 55 (I-55)	FAI 55 (I-55)
			RURAL INTERSTATE	RURAL INTERSTATE	RURAL INTERSTATE	RURAL INTERSTATE	RURAL INTERSTATE
			STRUCTURE NO.	STRUCTURE NO.	STRUCTURE NO.	STRUCTURE NO.	STRUCTURE NO.
			90% FED 10% STATE	90% FED 10% STATE	90% FED 10% STATE	90% FED 10% STATE	90% FED 10% STATE
			0059	057-0152	057-0173	057-0178	057-0182
			TOTAL	057-0153	057-0174	057-0179	057-0183
			QUANTITY	QUANTITY	QUANTITY	QUANTITY	QUANTITY
60100945	PIPE DRAINS 12"	FOOT	14			14	
60600605	CONCRETE CURB, TYPE B	FOOT	37		17		20
64200116	SHOULDER RUMBLE STRIPS, 16 INCH	FOOT	7,410	1,220	2,271	2,031	1,888
67000400	ENGINEERS FIELD OFFICE, TYPE A	CAL MO	12	3	3	3	3
67100100	MOBILIZATION	L SUM	1	0.25	0.25	0.25	0.25
70100207	TRAFFIC CONTROL AND PROTECTION, STANDARD 701402	EACH	8	2	2	2	2
70100420	TRAFFIC CONTROL AND PROTECTION, STANDARD 701411	EACH	3	3			
70100820	TRAFFIC CONTROL AND PROTECTION, STANDARD 701451	L SUM	1	1			
70102630	TRAFFIC CONTROL AND PROTECTION, STANDARD 701601	L SUM	1	1			
70107005	PAVEMENT MARKING BLACKOUT TAPE, 5"	FOOT	10,642	2,766	2,763	2,104	3,009
70107025	CHANGEABLE MESSAGE SIGN	CAL DA	300	75	75	75	75
70300221	TEMPORARY PAVEMENT MARKING - LINE 4"	FOOT	24,177	5,855	6,398	5,798	6,126
70400100	TEMPORARY CONCRETE BARRIER	FOOT	4,075	1,025	1,025	962	1,063
70400125	PINNING TEMPORARY CONCRETE BARRIER	EACH	36		24		12

\* SPECIALTY ITEM

MODEL: D:\p1\11... FILE NAME: P:\Effingham\3454 - PTB 188 DOT DS V\Work Order #6\Cadd\Sheet\0570912.dwg, 500.dgn



**CIVIL DESIGN, INC.**  
WBE / DBE  
EFFINGHAM, IL  
LICENSE #184.003222

USER NAME = abohnhoff	DESIGNED - WMK	REVISED -
DRAWN - DMM	REVISIONS -	
PLOT SCALE = 2.0000' / in.	CHECKED - RLH	REVISED -
PLOT DATE = 10/22/2021	DATE - 10/22/2021	REVISED -

**STATE OF ILLINOIS  
DEPARTMENT OF TRANSPORTATION**

**SUMMARY OF QUANTITIES**  
SCALE: N.T.S. SHEET 2 OF 5 SHEETS STA. TO STA.

F.A.I. RTE.	SECTION	COUNTY	TOTAL SHEETS	SHEET NO.
55	(57-1,57-2)BDS	MCLEAN	88	4
			CONTRACT NO. 70D64	
ILLINOIS FED. AID PROJECT				

CODE NO.	ITEM	UNIT	MCLEAN CO.	MCLEAN CO.	MCLEAN CO.	MCLEAN CO.	MCLEAN CO.
			FAI 55 (I-55)	FAI 55 (I-55)	FAI 55 (I-55)	FAI (I-55)	FAI 55 (I-55)
			RURAL INTERSTATE	RURAL INTERSTATE	RURAL INTERSTATE	RURAL INTERSTATE	RURAL INTERSTATE
			STRUCTURE NO.	STRUCTURE NO.	STRUCTURE NO.	STRUCTURE NO.	STRUCTURE NO.
			90% FED 10% STATE	90% FED 10% STATE	90% FED 10% STATE	90% FED 10% STATE	90% FED 10% STATE
			0059	057-0152	057-0173	057-0178	057-0182
			TOTAL	057-0153	057-0174	057-0179	057-0183
			QUANTITY	QUANTITY	QUANTITY	QUANTITY	QUANTITY
70400200	RELOCATE TEMPORARY CONCRETE BARRIER	FOOT	3,863	1,000	975	863	1,025
70600260	IMPACT ATTENUATORS, TEMPORARY (FULLY REDIRECTIVE,NARROW), TEST LEVEL 3	EACH	8	2	2	2	2
70600330	IMPACT ATTENUATORS, RELOCATE (FULLY REDIRECTIVE), TEST LEVEL 3)	EACH	8	2	2	2	2
* 78008330	POLYUREA PAVEMENT MARKING TYPE II - LINE 6"	FOOT	14,215	3,398	3,703	3,334	3,780
* 78011035	GROOVING FOR RECESSED PAVEMENT MARKING 7"	FOOT	14,215	3,398	3,703	3,334	3,780
78300201	PAVEMENT MARKING REMOVAL - GRINDING	SQ FT	6,651	1,629	1,736	1,640	1,646
X0322194	POLYMER MODIFIED PORTLAND CEMENT MORTAR	SQ FT	1,938		562		1,376
X0326223	FOAM, EXPANDING POLYURETHANE, HIGH-DENSITY	POUND	24,000			24,000	
X0550300	SLOPEWALL BREAKING	SQ YD	667			667	
X2700001	TEMPORARY RUMBLE STRIPS (SPECIAL)	EACH	64	16	16	16	16
X2810708	STONE DUMPED RIPRAP, CLASS A4 (SPECIAL)	SQ YD	667			667	
X5030250	BRIDGE DECK GROOVING (LONGITUDINAL)	SQ YD	5,527	2,077.0	896	1,150	1,404
X7200201	WIDTH RESTRICTION SIGNING	L SUM	1	0.25	0.25	0.25	0.25

\* SPECIALTY ITEM

MODEL: Default  
FILE NAME: P:\Effingham\184-PTB 188 IDOT DS V\Work Order #6\CaddSheet\0570912.dwg\_S00.dgn



CIVIL DESIGN, INC.  
WBE / DBE  
EFFINGHAM, IL  
LICENSE #184.003222

USER NAME = abohnhoff  
PLOT SCALE = 2.0000' / in.  
PLOT DATE = 10/22/2021

DESIGNED - WMK  
DRAWN - DMM  
CHECKED - RLH  
DATE - 10/22/2021

REVISED -  
REVISED -  
REVISED -  
REVISED -

STATE OF ILLINOIS  
DEPARTMENT OF TRANSPORTATION

SUMMARY OF QUANTITIES

SCALE: N.T.S. SHEET 3 OF 5 SHEETS STA. TO STA.

F.A.I. RTE.	SECTION	COUNTY	TOTAL SHEETS	SHEET NO.
55	(57-1,57-2)BDS	MCLEAN	88	5
CONTRACT NO. 70D64				
ILLINOIS FED. AID PROJECT				

CODE NO.	ITEM	UNIT	MCLEAN CO.	MCLEAN CO.	MCLEAN CO.	MCLEAN CO.	MCLEAN CO.
			FAI 55 (1-55)	FAI 55 (1-55)	FAI 55 (1-55)	FAI 55 (1-55)	FAI 55 (1-55)
			RURAL INTERSTATE	RURAL INTERSTATE	RURAL INTERSTATE	RURAL INTERSTATE	RURAL INTERSTATE
			STRUCTURE NO.	STRUCTURE NO.	STRUCTURE NO.	STRUCTURE NO.	STRUCTURE NO.
			90% FED 10% STATE	90% FED 10% STATE	90% FED 10% STATE	90% FED 10% STATE	90% FED 10% STATE
			0059	057-0152	057-0173	057-0178	057-0182
			TOTAL	057-0153	057-0174	057-0179	057-0183
			QUANTITY	QUANTITY	QUANTITY	QUANTITY	QUANTITY
Z0001903	STRUCTURAL STEEL REMOVAL	POUND	14,250	8,190			6,060
Z0001905	STRUCTURAL STEEL REPAIR	POUND	6,880	6,880			
Z0006012	BRIDGE DECK LATEX CONCRETE OVERLAY, 2 1/4 INCHES	SQ YD	2,220	860		622	738
Z0006018	BRIDGE DECK LATEX CONCRETE OVERLAY, 3 INCHES	SQ YD	2,966	1,754		1,212	
Z0012140	BRIDGE DECK SCARIFICATION 2"	SQ YD	2,836	860	616	622	738
Z0012146	BRIDGE DECK SCARIFICATION 2 3/4"	SQ YD	2,966	1,754		1,212	
Z0012152	BRIDGE DECK SCARIFICATION 3 1/2"	SQ YD	2,239		805		1,434
Z0012162	BRIDGE DECK MICROSILICA OVERLAY, 2 1/4 INCHES	SQ YD	616		616		
Z0012754	STRUCTURAL REPAIR OF CONCRETE (DEPTH EQUAL TO OR LESS THAN 5 INCHES)	SQ FT	1,733	1,226	60	377	70
Z0013798	CONSTRUCTION LAYOUT	L SUM	1	0.25	0.25	0.25	0.25
Z0016001	DECK SLAB REPAIR (FULL DEPTH, TYPE I)	SQ YD	166	62	8	36	60
Z0016002	DECK SLAB REPAIR (FULL DEPTH, TYPE II)	SQ YD	4	4			
Z0016702	DETOUR SIGNING	L SUM	1	1			
Z0029090	DIAMOND GRINDING (BRIDGE SECTION)	SQ YD	7,591	2,607	1,288	1,678	2,018

\* SPECIALTY ITEM

MODEL: Default  
FILE NAME: P:\Effingham\9454 - PTB 188 DOT D3 VAVWork Order #6\CaddSheet\0570912.dwg, 500.dgn



**CIVIL DESIGN, INC.**  
WBE / DBE  
EFFINGHAM, IL  
LICENSE #184.003222

USER NAME = abohnhoff  
PLOT SCALE = 2.0000' / in.  
PLOT DATE = 10/22/2021

DESIGNED - WMK  
DRAWN - DMM  
CHECKED - RLH  
DATE - 10/22/2021

REVISED -  
REVISED -  
REVISED -  
REVISED -

**STATE OF ILLINOIS  
DEPARTMENT OF TRANSPORTATION**

**SUMMARY OF QUANTITIES**

SCALE: N.T.S. SHEET 4 OF 5 SHEETS STA. TO STA.

F.A.I. RTE.	SECTION	COUNTY	TOTAL SHEETS	SHEET NO.
55	(57-1,57-2)BDS	MCLEAN	88	6
			CONTRACT NO. 70D64	
ILLINOIS FED. AID PROJECT				







	LOCATION	LENGTH FEET	31200500	40600275	40800029	42100380	42100615	42101300	48101498	48102100	48203053	48203100	64200116
			STABILIZED SUBBASE HMA 4"	BITUMINOUS MATERIALS (PRIME COAT)	BITUMINOUS MATERIALS (TACK COAT)	CONTINUOUSLY REINFORCED PCCP 14"	PAVEMENT REINFORCEMENT	PROTECTIVE COAT	AGGREGATE SHOULDERS TYPE B 4"	AGGREGATE WEDGE SHOULDER	HMA SHOULDERS 14"	HMA SHOULDERS	SHOULDER RUMBLE STRIPS
			SQ YD		LB	SQ YD	SQ YD	SQ YD	SQ YD	TON	SQ YD	TON	FOOT
057-0182	707+67.0 TO 710+62.0 LT	295			147.5					3.8		36.7	295
	708+83.0 TO 710+62.0 LT	179			53.7					2.3		13.4	179
	713+26.4 TO 715+99.0 LT	272.6			136.3					3.5		33.9	272.6
	713+26.4 TO 715+19.0 LT	192.6			57.8					2.5		14.4	192.6
057-0183	707+33.0 TO 709+85.0 RT	252			126.0					3.3		31.4	252
	708+06.0 TO 709+85.0 RT	179			53.7					2.3		13.4	179
	709+85.0 TO 710+27.0 RT	42	126.0	168.1	67.2	112.0	112.0	112.0	28.0	0.5	74.7		42
	712+87.6 TO 713+15.0 RT	27.4	82.2	109.6	43.8	73.1	73.1	73.1	18.3	0.4	48.7		27.4
	713+15.0 TO 714+97.0 RT	182			54.6					2.3		13.6	182
	713+15.0 TO 715+81.0 RT	266			133.0					3.4		33.1	266
057-0173	777+32.0 TO 780+01.0 LT	269			134.5					3.5		33.5	269
	777+47.0 TO 780+01.0 LT	254			76.2					3.3		19	254
	780+01.0 TO 780+64.0 LT	63	189.0	252.0	100.8	168.0	168.0	168.0	42.0	0.8	112		63
	782+35.2 TO 782+99.0 LT	63.8	191.4	255.2	102.1	170.1	170.1	170.1	42.5	0.8	113.4		63.8
	782+99.0 TO 785+00.2 BK LT	201.2			100.6					2.6		25	201.2
	782+99.0 TO 785+00.2 BK LT	201.2			60.4					2.6		15	201.2
	100+00.0 AH TO 100+53.0 LT	53			26.5					0.7		6.6	53
	100+00.0 AH TO 100+44.0 LT	44			13.2					0.6		3.3	44
057-0174	777+45.0 TO 780+04.0 RT	259			129.5					3.3		32.2	259
	777+68.0 TO 780+04.0 RT	236			70.8					3		17.6	236
	780+04.0 TO 780+67.5 RT	65	195.0	260.1	104.0	173.3	173.3	173.3	43.3	0.8	115.6		65
	782+33.4 TO 782+97.0 RT	63.6	190.8	254.5	101.8	169.6	169.6	169.6	42.4	0.8	113.1		63.6
	782+97.0 TO 785+00.2 BK RT	203.2			101.6					2.6		25.3	203.2
	782+97.0 TO 785+00.2 BK RT	203.2			61.0					2.6		15.2	203.2
	100+00.0 AH TO 100+22.0 RT	22			6.6					0.3		1.6	22
	100+00.0 AH TO 100+70.0 RT	70			35.0					0.9		8.7	70
057-0152	394+74.0 TO 397+23.8 LT	249.8			74.9					3.2		18.7	249.8
	399+91.7 TO 402+37.0 LT	245.3			122.7					3.2		30.5	245.3
	399+91.7 TO 402+24.0 LT	232.3			69.7					3		17.3	232.3
057-0153	394+75.0 TO 397+23.9 RT	248.9			74.7					3.2		18.6	248.9
	399+91.1 TO 402+35.0 RT	243.9			73.2					3.1		18.2	243.9
057-0178	407+60.0 TO 410+18.6 LT	258.6			77.6					3.3		19.3	258.6
	407+65.0 TO 410+18.6 LT	253.6			126.8					3.3		31.6	253.6
	412+37.3 TO 414+73.0 LT	235.7			117.9					3		29.3	235.7
	412+37.3 TO 414+99.0 LT	261.7			78.5					3.4		19.5	261.7
057-0179	407+63.0 TO 410+20.5 RT	257.5			128.8					3.3		32	257.5
	407+79.0 TO 410+20.5 RT	241.5			72.5					3.1		18	241.5
	412+38.0 TO 415+06.0 RT	268			80.4					3.5		20	268
	412+38.0 TO 414+92.00 RT	254			127.0					3.3		31.6	254
	TOTAL		974.4	1299.5	3322.9	866.1	866.1	866.1	216.5	95.4	577.5	697.5	7409.6
	USE		974	1300	3323	866	866	866	217	95	578	698	7410

LOCATION	X2700001 TEMPORARY RUMBLE STRIPS (SPECIAL)
	EACH
SN 057-0182 (SB)	8
SN 057-0183 (NB)	8
SN 057-173 (SB)	8
SN 057-174 (NB)	8
SN 057+0152 (SB)	8
SN 057+0153 (NB)	8
SN 057+0178 (SB)	8
SN 057-179 (NB)	8
TOTAL	64

LOCATION	20200100	28100107	28200200	54213447	60100945
	EARTH EXCAVATION CU YD	STONE RIPRAP, CLASS A4 SQ YD	FILTER FABRIC SQ YD	END SECTIONS 12" EACH	PIPE DRAINS 12" FOOT
410+22 RT	6.8	11.1	11.1		
410+22 LT	6.8	11.1	11.1		
410+40 LT	55.2	90.4	90.4	1	7
410+40 RT	54.8	89.6	89.6	1	7
412+31 LT	6.8	11.1	11.1		
412+31 RT	6.8	11.1	11.1		
412+35 LT	55.7	91.1	91.1		
412+35 RT	54.9	89.8	89.8		
TOTAL	247.8	405.3	405.3	2	14
USE	248	405	405	2	14

MODEL: D:\p4\h...  
 FILE NAME: P:\Effingham\184...  
 ORDER: 184...  
 SCHEDULES:



**CIVIL DESIGN, INC.**  
 WBE / DBE  
 EFFINGHAM, IL  
 LICENSE #184.003222

USER NAME = rhanfland	DESIGNED - WMK	REVISED - 12/1/2021
PLOT SCALE = 2,000' / in.	DRAWN - DMM	REVISED -
PLOT DATE = 12/1/2021	CHECKED - RLH	REVISED -
	DATE - 12/1/2021	REVISED -

**STATE OF ILLINOIS**  
**DEPARTMENT OF TRANSPORTATION**

SCHEDULE OF QUANTITIES			
SCALE: N.T.S.	SHEET 1	OF 3 SHEETS	STA. TO STA.

F.A.I. RTE. 55	SECTION (57-1,57-2)BDS	COUNTY MCLEAN	TOTAL SHEETS 88	SHEET NO. 9
CONTRACT NO. 70D64				
ILLINOIS FED. AID PROJECT				

LOCATION	LENGTH FEET	44000100	44000300	44000157	44004250	50105220
		PAVEMENT REMOVAL	CURB REMOVAL	HMA SURFACE REMOVAL, 2"	PAVED SHOULDER REMOVAL	PIPE CULVERT REMOVAL
		SQ YD	LF	SQ YD	SQ YD	LF
057-0182	712+88.0 TO 713+07.8 LT	20	20			
	707+67.0 TO 710+62.0 LT	295		327.8		
	708+83.0 TO 710+62.0 LT	179		119.3		
	713+26.4 TO 715+99.0 LT	272.6		302.9		
	713+26.4 TO 715+19.0 LT	192.6		128.4		
057-0183	707+33.0 TO 709+85.0 RT	252		280.0		
	708+06.0 TO 709+85.0 RT	179		119.3		
	709+85.0 TO 710+27.0 RT	42	112.0		74.7	
	712+87.6 TO 713+15.0 RT	27.4	73.1		48.7	
	713+15.0 TO 714+97.0 RT	182		121.3		
713+15.0 TO 715+81.0 RT	266		295.6			
057-0173	777+32.0 TO 780+01.0 LT	269		298.9		
	777+47.0 TO 780+01.0 LT	254		169.3		
	780+01.0 TO 780+64.0 LT	63	168.0		112.0	
	782+35.2 TO 782+99.0 LT	63.8	170.1		113.4	
	782+99.0 TO 785+00.2 BK LT	201.2		223.6		
	782+99.0 TO 785+00.2 BK LT	201.2		134.1		
	100+00.0 AH TO 100+53.0 LT	53		58.9		
	100+00.0 AH TO 100+44.0 LT	44		29.3		
057-0174	777+45.0 TO 780+04.0 RT	259		287.8		
	777+68.0 TO 780+04.0 LT	236		157.3		
	780+04.0 TO 780+67.5 RT	65	173.3		115.6	
	782+33.4 TO 782+97.0 RT	63.6	169.6		113.1	
	782+97.0 TO 785+00.2 BK RT	203.2		225.8		
	782+97.0 TO 785+00.2 BK RT	203.2		135.5		
	100+00.0 AH TO 100+22.0 RT	22		14.7		
	100+00.0 AH TO 100+70.0 RT	70		77.8		
057-0152	394+74.0 TO 397+23.8 LT	249.8		166.5		
	399+91.7 TO 402+37.0 LT	245.3		272.6		
	399+91.7 TO 402+24.0 LT	232.3		154.9		
057-0153	394+75.0 TO 397+23.9 RT	248.9		165.9		
	399+91.1 TO 402+35.0 RT	243.9		162.6		
057-0178	412+13 TO 412+31 LT	17	17			
	407+60.0 TO 410+18.6 LT	258.6		172.4		
	407+65.0 TO 410+18.6 LT	253.6		281.8		
	412+37.3 TO 414+99.0 LT	261.7		290.8		
	412+37.3 TO 414+73.0 LT	235.7		157.1		
	410+40.3 LT (057-0178)					67
057-0179	407+63.0 TO 410+20.5 RT	257.5		286.1		
	407+79.0 TO 410+20.5 RT	241.5		161.0		
	412+38.0 TO 415+06.0 RT	268		178.7		
	412+38.0 TO 414+92.00 RT	254		282.2		
	410+41.0 RT (057-0179)					67
TOTAL		866.1	37	6240.2	577.5	134
USE		866	37	6240	578	134

LOCATION	60600605 CONCRETE CURB TYPE B
	FOOT
712+88 TO 713+08 LT (057-0182)	20
412+13 TO 412+31 LT (057-0178)	17
TOTAL	37

LOCATION	70400100	70400200	70600260	70600330	70400125
	TEMP CONCRETE BARRIER	REL TEMP CONCRETE BARRIER	IMP ATT TEMP FRN TL3	IMP ATT REL FRD TL3	PIN TEMP CONCRETE BARRIER
	FOOT	FOOT	EACH	EACH	FOOT
SN 057-0182 (SB)					
STAGE 1					
STA. 710+38.90 TO STA. 715+38.30	500		1		6
STAGE 2					
STA. 710+38.90 TO STA. 715+13.40		475		1	6
SN 057-0183 (NB)					
STAGE 1					
STA. 707+85.60 TO STA. 713+47.50	562.5		1		
STAGE 2					
STA. 707+98.00 TO STA. 713+47.50		550		1	
SN 057-173 (SB)					
STAGE 1					
STA. 779+69.20 TO STA. 784+98.20	525		1		6
STAGE 2					
STA. 779+69.20 TO STA. 784+98.30		525		1	6
SN 057-174 (NB)					
STAGE 1					
STA. 778+05.00 TO STA. 783+21.40	500		1		6
STAGE 2					
STA. 778+54.20 TO STA. 783+21.40		450		1	6
SN 057+0152 (SB)					
STAGE 1					
STA. 396+98.70 TO STA. 401+98.10	500		1		
STAGE 2					
STA. 396+98.70 TO STA. 402+10.60	12.5	500		1	
SN 057+0153 (NB)					
STAGE 1					
STA. 395+24.30 TO STA. 400+23.70	500		1		
STAGE 2					
STA. 395+11.80 TO STA. 400+23.70	12.5	500		1	
SN 057+0178 (SB)					
STAGE 1					
STA. 409+87.30 TO STA. 414+84.40	500		1		
STAGE 2					
STA. 409+87.30 TO STA. 414+22.30		425		1	
SN 057-179 (NB)					
STAGE 1					
STA. 408+08.70 TO STA. 412+70.50	462.5		1		
STAGE 2					
STA. 408+21.10 TO STA. 412+70.50		437.5		1	
TOTAL	4075	3862.5	8	8	36
USE	4075	3863	8	8	36

MODEL: D:\p4\h...  
 FILE NAME: P:\Effingham\m3454...\_PTB\_1801\_IDOT\_DS\_V\Work Order #6\AddSheet\057012\_01\_SCHEDULES.dgn



**CIVIL DESIGN, INC.**  
 WBE / DBE  
 EFFINGHAM, IL  
 LICENSE #184.003222

USER NAME = rhanfland	DESIGNED - WMK	REVISED - 12/1/2021
PLOT SCALE = 2,000' / in.	DRAWN - DMM	REVISED -
PLOT DATE = 12/7/2021	CHECKED - RLH	REVISED -
	DATE - 12/7/2021	REVISED -

**STATE OF ILLINOIS**  
**DEPARTMENT OF TRANSPORTATION**

**SCHEDULE OF QUANTITIES**  
 SHEET 2 OF 3 SHEETS STA. TO STA.

F.A.I. RTE.	SECTION	COUNTY	TOTAL SHEETS	SHEET NO.
55	(57-1,57-2)BDS	MCLEAN	88	10
			CONTRACT NO. 70D64	
ILLINOIS FED. AID PROJECT				

LOCATION	COLOR	70300221 TEMPORARY PAVEMENT MARKING - LINE 4" - PAINT FOOT	78300201 PAVEMENT MARKING REMOVAL GRINDING SQ FT	70107005 PAVEMENT MARKING BLACKOUT TAPE, 5" FOOT
		SN 057-0182 (SB)		
STAGE 1				
STA. 707+67 TO STA. 715+99	YELLOW	833	190	833
STA. 707+67 TO STA. 715+99	WHITE	833	190	
STAGE 2				
STA. 708+83 TO STA. 715+20	YELLOW	691	230	
STA. 708+83 TO STA. 715+20	WHITE	691	230	637
SN 057-0183 (NB)				
STAGE 1				
STA. 707+33 TO STA. 715+81	YELLOW	848	173	848
STA. 707+33 TO STA. 715+81	WHITE	848	173	
STAGE 2				
STA. 707+98 TO STA. 714+97	YELLOW	691	230	
STA. 707+98 TO STA. 714+97	WHITE	691	230	691
SN 057-173 (SB)				
STAGE 1				
STA. 777+32 TO STA. 100+53	YELLOW	810	172	
STA. 777+32 TO STA. 100+53	WHITE	810	172	714
STAGE 2				
STA. 777+48 TO STA. 100+44	YELLOW	790	263	
STA. 777+48 TO STA. 100+44	WHITE	790	263	640
SN 057-174 (NB)				
STAGE 1				
STA. 777+45 TO STA. 100+70	YELLOW	836	179	
STA. 777+45 TO STA. 100+70	WHITE	836	179	742
STAGE 2				
STA. 777+68 TO STA. 100+22	YELLOW	763	254	
STA. 777+68 TO STA. 100+22	WHITE	763	254	667
SN 057+0152 (SB)				
STAGE 1				
STA. 394+72 TO STA. 402+37	YELLOW	765	166	
STA. 394+72 TO STA. 402+37	WHITE	521	33	583
STAGE 2				
STA. 394+74 TO STA. 402+54	YELLOW	1015	338	
STA. 394+74 TO STA. 402+54	WHITE	983	328	1134
SN 057+0153 (NB)				
STAGE 1				
STA. 394+73 TO STA. 402+63	YELLOW	789	174	
STA. 394+73 TO STA. 402+63	WHITE	262	84	291
STAGE 2				
STA. 394+75 TO STA. 402+35	YELLOW	760	253	
STA. 394+75 TO STA. 402+35	WHITE	760	253	758
SN 057+0178 (SB)				
STAGE 1				
STA. 407+65 TO STA. 414+73	YELLOW	709	162	
STA. 407+65 TO STA. 414+73	WHITE	709	162	529
STAGE 2				
STA. 407+60 TO STA. 414+99	YELLOW	740	247	
STA. 407+60 TO STA. 414+99	WHITE	740	247	560
SN 057-179 (NB)				
STAGE 1				
STA. 407+63 TO STA. 414+92	YELLOW	725	169	
STA. 407+63 TO STA. 414+92	WHITE	725	169	508
STAGE 2				
STA. 407+79 TO STA. 415+06	YELLOW	725	242	
STA. 407+79 TO STA. 415+06	WHITE	725	242	507
TOTAL		24177	6651	10642

LOCATION	78008330 POLYUREA PAVEMENT MARKING TYPE II, 6" FOOT			78011035 GROOVING FOR RECESSED PAVEMENT MARKING 7"
	SOLID YELLOW	SOLID WHITE	SKIP DASH WHITE	FOOT
SN 057-0182 707+67 TO 715+99	832	832	208	1872
SN 057-0183 707+33 TO 715+81	848	848	212	1908
SN 057-173 777+32 TO 100+53	AH 821	821	205	1847
SN 057-174 777+45 TO 100+70	AH 825	825	206	1856
SN 057+0152 394+74 TO 402+24	750	750	188	1688
SN 057+0153 394+75 TO 402+35	760	760	190	1710
SN 057+0178 407+60 TO 414+99	739	739	185	1663
SN 057-179 407+63 TO 415+06	743	743	185	1671
TOTAL	6318	6318	1579	14215
USE	14215			14215

MODEL: D:\cfd\h...  
 FILE NAME: P:\Effingham\mm3454...PTB 1801 IDOT DS VAVWork Order #6\CardSheet\0570912\_01\_SCHEDULES.dgn



**CIVIL DESIGN, INC.**  
 WBE / DBE  
 EFFINGHAM, IL  
 LICENSE # 184.003222

USER NAME = rhanlland  
 PLOT SCALE = 2,0000 ' / in.  
 PLOT DATE = 10/28/2021

DESIGNED - WMK  
 DRAWN - DMM  
 CHECKED - RLH  
 DATE - 10/28/2021

REVISED -  
 REVISED -  
 REVISED -  
 REVISED -

**STATE OF ILLINOIS  
 DEPARTMENT OF TRANSPORTATION**

**SCHEDULE OF QUANTITIES**

SHEET 3 OF 3 SHEETS STA. TO STA.

F.A.I. RTE.	SECTION	COUNTY	TOTAL SHEETS	SHEET NO.
55	(57-1,57-2)BDS	MCLEAN	88	11
CONTRACT NO. 70D64				
ILLINOIS FED. AID PROJECT				

S6, T25N, R4E

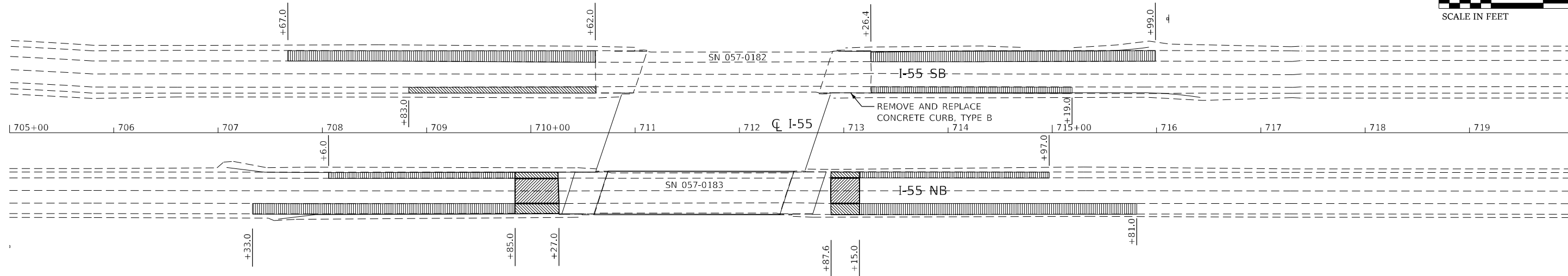
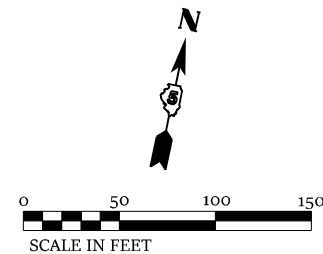

- PAVEMENT REMOVAL AND REPLACEMENT WITH CONTINUOUSLY REINFORCED PORTLAND CEMENT CONCRETE PAVEMENT 14"
- PAVED SHOULDER REMOVAL AND REPLACEMENT WITH HOT-MIX ASPHALT SHOULDERS, 14"
- HMA SURFACE REMOVAL 2" & HMA SHOULDERS

S5, T25N, R4E

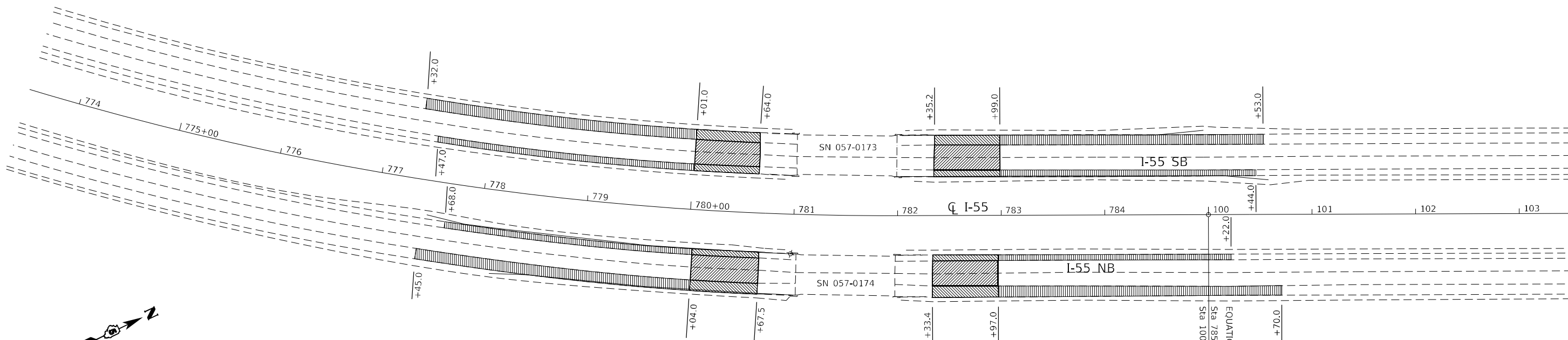

- PAVEMENT REMOVAL AND REPLACEMENT WITH CONTINUOUSLY REINFORCED PORTLAND CEMENT CONCRETE PAVEMENT 14"
- PAVED SHOULDER REMOVAL AND REPLACEMENT WITH HOT-MIX ASPHALT SHOULDERS, 14"
- HMA SURFACE REMOVAL 2" & HMA SHOULDERS

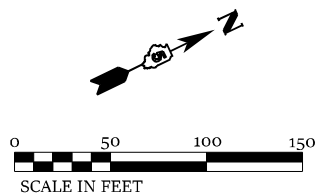

MODEL: D570012\_Plan4  
FILE NAME: P:\EIT\m3454...PTB 1801.DOT.D5 VAV\Work Order #6\CardSheet\0570664\_ch\_Plan1.dgn



CIVIL DESIGN, INC.  
WBE / DBE  
EFFINGHAM, IL  
LICENSE # 184.003222

USER NAME = rhanland	DESIGNED - WMK	REVISED -
	DRAWN - DMM	REVISED -
PLOT SCALE = 100,0000' / in.	CHECKED - RLH	REVISED -
PLOT DATE = 10/28/2021	DATE - 10/28/2021	REVISED -

STATE OF ILLINOIS  
DEPARTMENT OF TRANSPORTATION

<b>I-55 PLAN SHEET</b>	
SCALE: 100,0000' / in.	SHEET 1 OF 2 SHEETS
STA. 705+00.00	TO STA. 103+50.00

F.A.I. RTE.	SECTION	COUNTY	TOTAL SHEETS	SHEET NO.
55	(57-1,57-2)BDS	MCLEAN	88	12
CONTRACT NO. 70D64				
ILLINOIS FED. AID PROJECT				

S11, T26N, R4E

S2, T26N, R4E

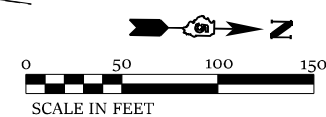
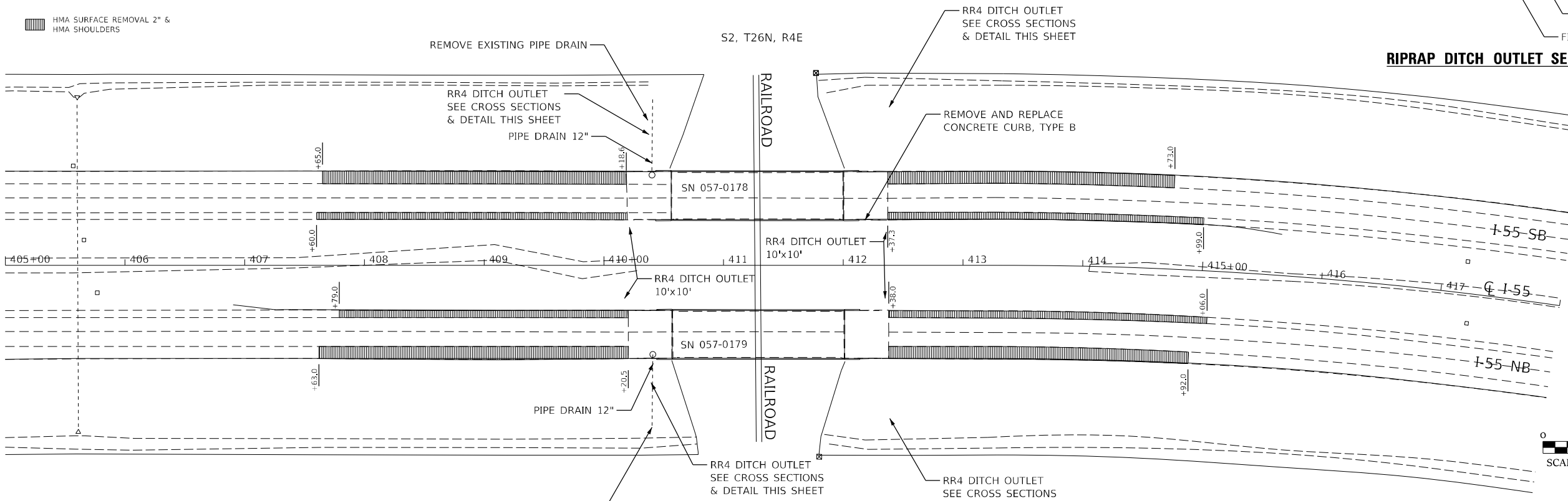
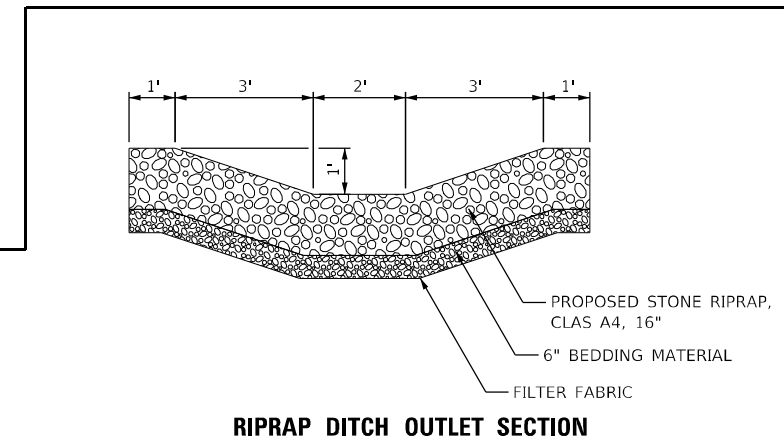
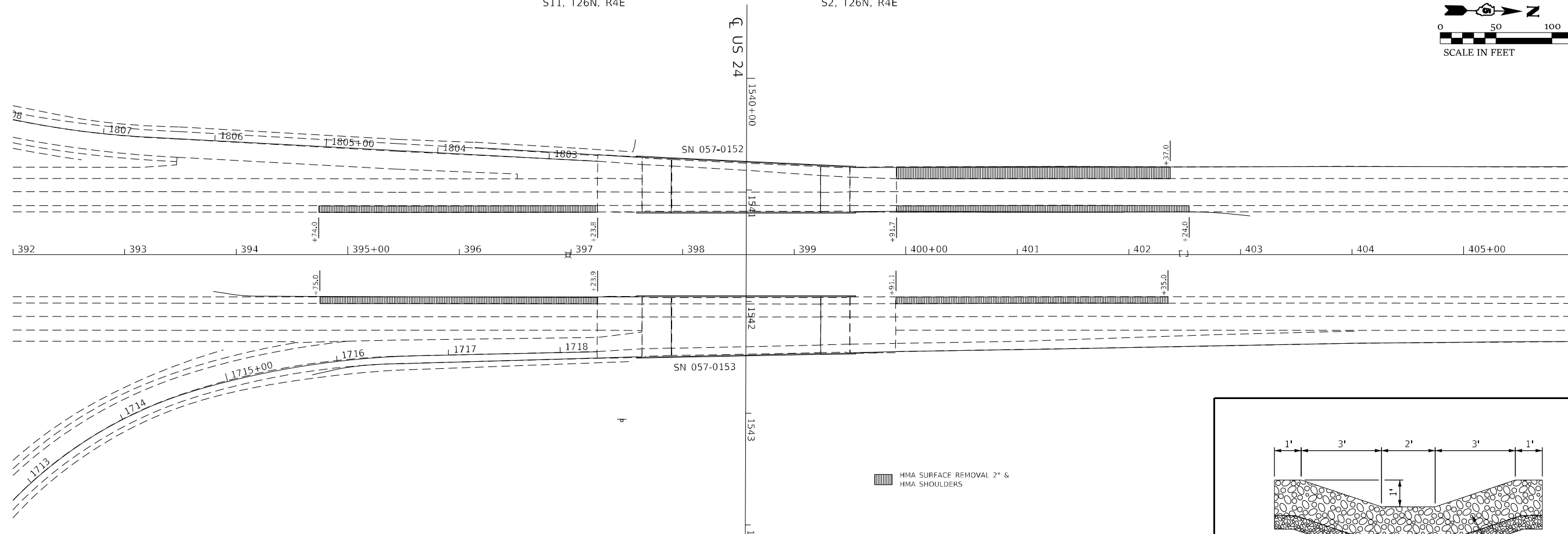
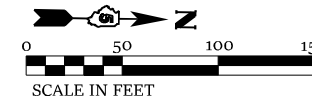

MODEL: D:\70012\_Plan17  
 FILE NAME: P:\EIT\m35454...PTB 1801.DOT.DS V:\Work Order #6\Road\Sheet\0570664.ctb Pbn2.com



**CIVIL DESIGN, INC.**  
WBE / DBE  
EFFINGHAM, IL  
LICENSE # 184.003222

USER NAME = rhanland	DESIGNED - WMK	REVISED -
	DRAWN - DMM	REVISED -
PLOT SCALE = 100.0000' / in.	CHECKED - RLH	REVISED -
PLOT DATE = 10/28/2021	DATE - 10/28/2021	REVISED -

**STATE OF ILLINOIS  
DEPARTMENT OF TRANSPORTATION**

**I-55  
PLAN SHEET**  
SCALE: 100.0000' / in SHEET 2 OF 2 SHEETS STA. 405+00 TO STA. 735+00.00

F.A.I. RTE.	SECTION	COUNTY	TOTAL SHEETS	SHEET NO.
55	(57-1,57-2)BD5	MCLEAN	88	13
CONTRACT NO. 70D64				
ILLINOIS FED. AID PROJECT				

IF WORKING ON CONCURRENT STRUCTURES, DRUMS WITH STEADY BURN MONODIRECTIONAL LIGHTS AT 100' CENTERS SHALL BE USED PER HIGHWAY STANDARD 701402. ONLY DRUMS ALONG THE LANE SHIFTS AND 500' IN ADVANCE OF THE LANE SHIFTS WILL REQUIRE MONODIRECTIONAL LIGHTS. OTHER DRUMS ALONG THE TANGENT BETWEEN STRUCTURES WILL NOT REQUIRE LIGHTS. CHECK BARRICADES WILL BE REQUIRED EVERY 1000'. COST INCLUDED WITH TRAFFIC CONTROL AND PROTECTION STANDARD 701402.

**TEMPORARY CONCRETE BARRIER LAYOUT - STAGE I**  
**S.N. 057-0183 (NB) & S.N. 057-0182 (SB)**

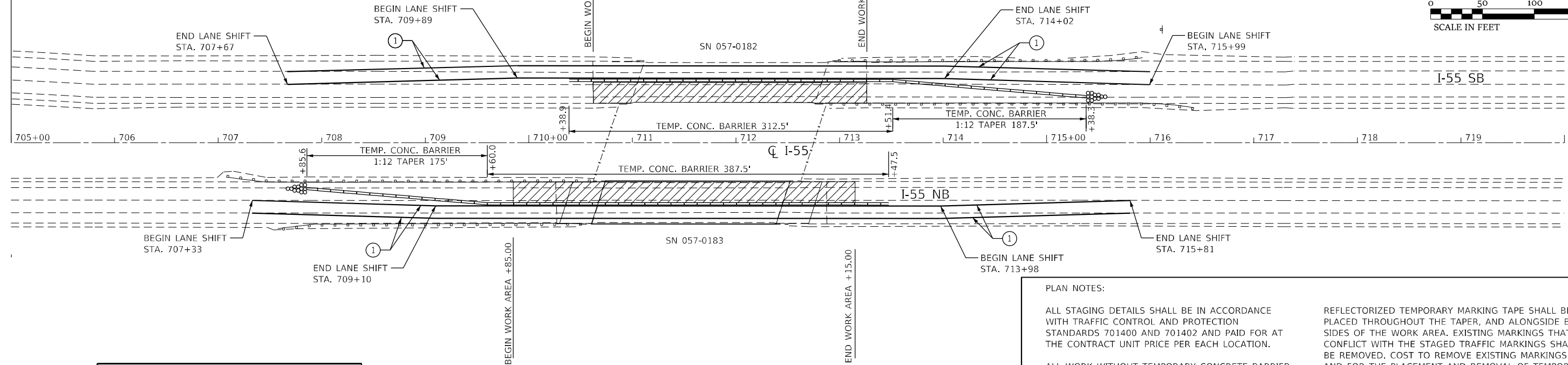
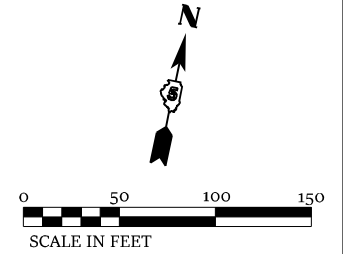

SYMBOLS	
	TEMPORARY CONCRETE BARRIER
	IMPACT ATTENUATOR
	WORK AREA
	TEMPORARY PAVEMENT MARKINGS

**PLAN NOTES:**

ALL STAGING DETAILS SHALL BE IN ACCORDANCE WITH TRAFFIC CONTROL AND PROTECTION STANDARDS 701400 AND 701402 AND PAID FOR AT THE CONTRACT UNIT PRICE PER EACH LOCATION.

ALL WORK WITHOUT TEMPORARY CONCRETE BARRIER IN PLACE SHALL BE IN ACCORDANCE WITH TRAFFIC CONTROL AND PROTECTION STANDARDS 701400 AND 701401.

FOR ADDITIONAL DETAILS ASSOCIATED WITH TEMPORARY CONCRETE BARRIER, SEE TRAFFIC CONTROL AND PROTECTION STANDARD 704001.

VERTICAL PANELS WITH LIGHTS AND REFLECTORS SHALL BE ATTACHED AT 25 FOOT CENTERS TO THE BARRIER WALL AND GUARDRAIL. COST INCLUDED WITH TRAFFIC CONTROL AND PROTECTION STANDARD 701402.

REFLECTORIZED TEMPORARY MARKING TAPE SHALL BE PLACED THROUGHOUT THE TAPER, AND ALONGSIDE BOTH SIDES OF THE WORK AREA. EXISTING MARKINGS THAT CONFLICT WITH THE STAGED TRAFFIC MARKINGS SHALL BE REMOVED. COST TO REMOVE EXISTING MARKINGS AND FOR THE PLACEMENT AND REMOVAL OF TEMPORARY MARKINGS SHALL BE INCLUDED WITH TRAFFIC CONTROL AND PROTECTION STANDARD 701402.

PRIOR TO ROUTING TRAFFIC ONTO THE SHOULDERS, THE CONTRACTOR SHALL SECURE ANY GRATES ON SHOULDER INLETS AS DIRECTED BY THE ENGINEER. THIS WORK SHALL BE PAID FOR ACCORDING TO ARTICLE 109.04 OF THE STANDAR SPECIFICATIONS.

PORTABLE CHANGEABLE MESSAGE SIGNS ARE REQUIRED SEVEN DAYS PRIOR TO CONSTRUCTION. THE RESIDENT ENGINEER OR TRAFFIC CONTROL SUPERVISOR SHALL PROVIDE AN APPROPRIATE MESSAGE.

**TEMPORARY CONCRETE BARRIER LAYOUT - STAGE II**  
**S.N. 057-0183 (NB) & S.N. 057-0182 (SB)**

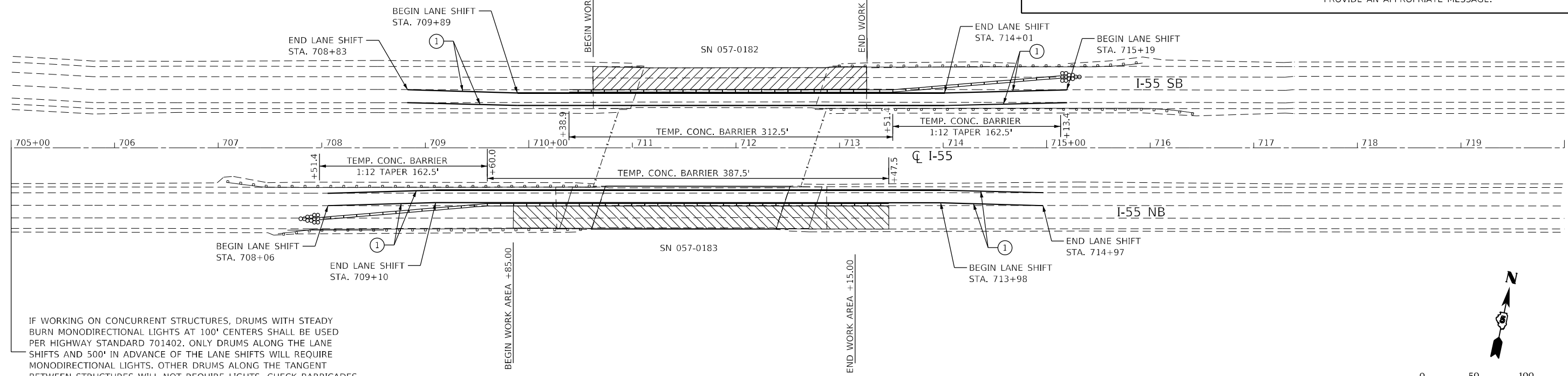

IF WORKING ON CONCURRENT STRUCTURES, DRUMS WITH STEADY BURN MONODIRECTIONAL LIGHTS AT 100' CENTERS SHALL BE USED PER HIGHWAY STANDARD 701402. ONLY DRUMS ALONG THE LANE SHIFTS AND 500' IN ADVANCE OF THE LANE SHIFTS WILL REQUIRE MONODIRECTIONAL LIGHTS. OTHER DRUMS ALONG THE TANGENT BETWEEN STRUCTURES WILL NOT REQUIRE LIGHTS. CHECK BARRICADES WILL BE REQUIRED EVERY 1000'. COST INCLUDED WITH TRAFFIC CONTROL AND PROTECTION STANDARD 701402.

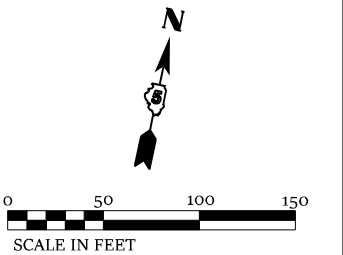

MODEL: D:\2021\12\_Plan4 FILE NAME: PLTEMPCONC.dwg PLOT DATE: 10/21/2021 10:13:01 AM



USER NAME = rhanland	DESIGNED - WMK	REVISED -
	DRAWN - DMM	REVISED -
PLOT SCALE = 100,0000' / in.	CHECKED - RLH	REVISED -
PLOT DATE = 10/21/2021	DATE - 10/21/2021	REVISED -

**STATE OF ILLINOIS DEPARTMENT OF TRANSPORTATION**

**TEMPORARY CONCRETE BARRIER LAYOUT**  
**S.N. 057-0182 SB & S.N. 057-0183 NB**  
 SCALE: 100,0000' / in SHEET 4 OF 28 SHEETS STA. 705+00.00 TO STA. 735+00.00

F.A.I. RTE.	SECTION	COUNTY	TOTAL SHEETS	SHEET NO.
55	(57-1,57-2)BD5	MCLEAN	88	14
CONTRACT NO. 70D64				
ILLINOIS FED. AID PROJECT				

IF WORKING ON CONCURRENT STRUCTURES, DRUMS WITH STEADY BURN MONODIRECTIONAL LIGHTS AT 100' CENTERS SHALL BE USED PER HIGHWAY STANDARD 701402. ONLY DRUMS ALONG THE LANE SHIFTS AND 500' IN ADVANCE OF THE LANE SHIFTS WILL REQUIRE MONODIRECTIONAL LIGHTS. OTHER DRUMS ALONG THE TANGENT BETWEEN STRUCTURES WILL NOT REQUIRE LIGHTS. CHECK BARRICADES WILL BE REQUIRED EVERY 1000'. COST INCLUDED WITH TRAFFIC CONTROL AND PROTECTION STANDARD 701402.

**TEMPORARY CONCRETE BARRIER LAYOUT - STAGE I**  
**S.N. 057-0174 (NB) & S.N. 057-0173 (SB)**

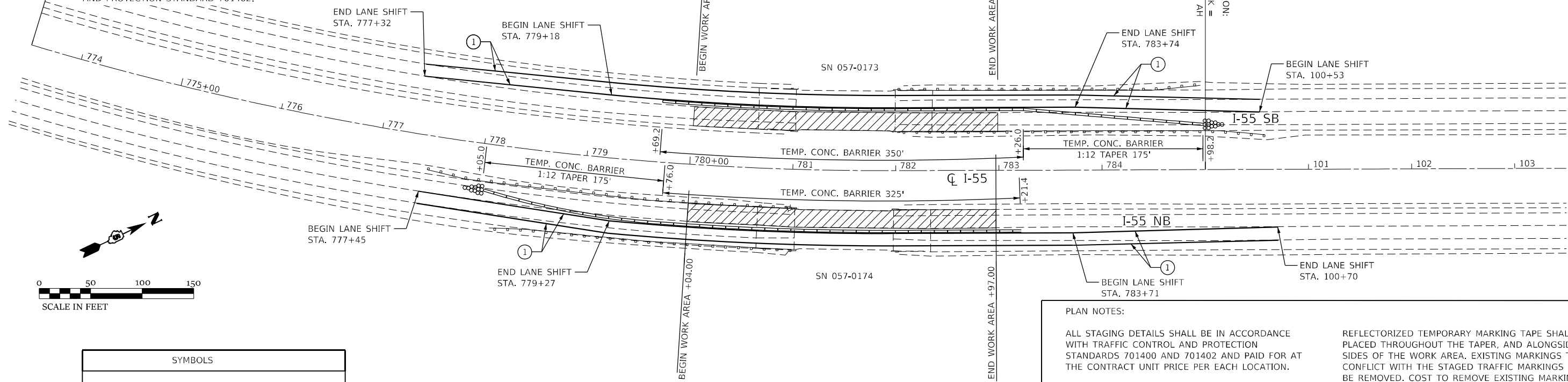

SYMBOLS	
	TEMPORARY CONCRETE BARRIER
	IMPACT ATTENUATOR
	WORK AREA
	TEMPORARY PAVEMENT MARKINGS

**PLAN NOTES:**

ALL STAGING DETAILS SHALL BE IN ACCORDANCE WITH TRAFFIC CONTROL AND PROTECTION STANDARDS 701400 AND 701402 AND PAID FOR AT THE CONTRACT UNIT PRICE PER EACH LOCATION.

ALL WORK WITHOUT TEMPORARY CONCRETE BARRIER IN PLACE SHALL BE IN ACCORDANCE WITH TRAFFIC CONTROL AND PROTECTION STANDARDS 701400 AND 701401.

FOR ADDITIONAL DETAILS ASSOCIATED WITH TEMPORARY CONCRETE BARRIER, SEE TRAFFIC CONTROL AND PROTECTION STANDARD 704001.

VERTICAL PANELS WITH LIGHTS AND REFLECTORS SHALL BE ATTACHED AT 25 FOOT CENTERS TO THE BARRIER WALL AND GUARDRAIL. COST INCLUDED WITH TRAFFIC CONTROL AND PROTECTION STANDARD 701402.

REFLECTORIZED TEMPORARY MARKING TAPE SHALL BE PLACED THROUGHOUT THE TAPER, AND ALONGSIDE BOTH SIDES OF THE WORK AREA. EXISTING MARKINGS THAT CONFLICT WITH THE STAGED TRAFFIC MARKINGS SHALL BE REMOVED. COST TO REMOVE EXISTING MARKINGS AND FOR THE PLACEMENT AND REMOVAL OF TEMPORARY MARKINGS SHALL BE INCLUDED WITH TRAFFIC CONTROL AND PROTECTION STANDARD 701402.

PRIOR TO ROUTING TRAFFIC ONTO THE SHOULDERS, THE CONTRACTOR SHALL SECURE ANY GRATES ON SHOULDER INLETS AS DIRECTED BY THE ENGINEER. THIS WORK SHALL BE PAID FOR ACCORDING TO ARTICLE 109.04 OF THE STANDAR SPECIFICATIONS.

PORTABLE CHANGEABLE MESSAGE SIGNS ARE REQUIRED SEVEN DAYS PRIOR TO CONSTRUCTION. THE RESIDENT ENGINEER OR TRAFFIC CONTROL SUPERVISOR SHALL PROVIDE AN APPROPRIATE MESSAGE.

**TEMPORARY CONCRETE BARRIER LAYOUT - STAGE II**  
**S.N. 057-0174 (NB) & S.N. 057-0173 (SB)**

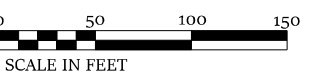
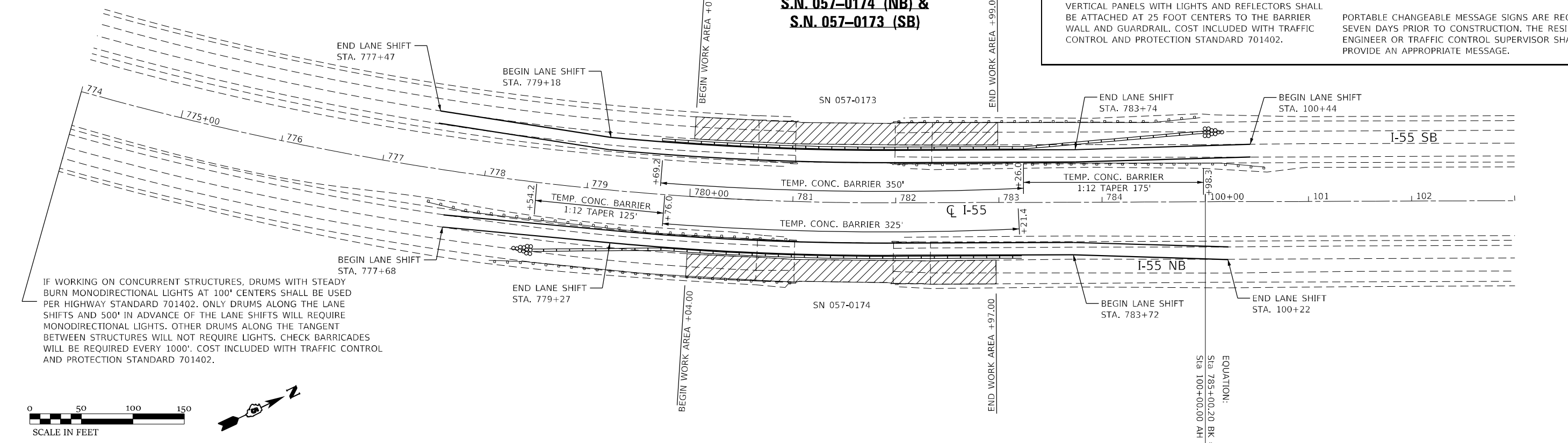

IF WORKING ON CONCURRENT STRUCTURES, DRUMS WITH STEADY BURN MONODIRECTIONAL LIGHTS AT 100' CENTERS SHALL BE USED PER HIGHWAY STANDARD 701402. ONLY DRUMS ALONG THE LANE SHIFTS AND 500' IN ADVANCE OF THE LANE SHIFTS WILL REQUIRE MONODIRECTIONAL LIGHTS. OTHER DRUMS ALONG THE TANGENT BETWEEN STRUCTURES WILL NOT REQUIRE LIGHTS. CHECK BARRICADES WILL BE REQUIRED EVERY 1000'. COST INCLUDED WITH TRAFFIC CONTROL AND PROTECTION STANDARD 701402.

MODEL: D:\670012\_Plan16 FILE NAME: PLTEMPCONC05701730174.dwg



CIVIL DESIGN, INC.  
 WBE / DBE  
 EFFINGHAM, IL  
 LICENSE # 184.003222

USER NAME = rhanland	DESIGNED - WMK	REVISED -
	DRAWN - DMM	REVISED -
PLOT SCALE = 100.0000' / in.	CHECKED - RLH	REVISED -
PLOT DATE = 10/21/2021	DATE - 10/21/2021	REVISED -

STATE OF ILLINOIS  
 DEPARTMENT OF TRANSPORTATION

TEMPORARY CONCRETE BARRIER LAYOUT  
 S.N. 057-0173 SB & S.N. 057-0174 NB  
 SCALE: 100.0000' / in SHEET 1 OF 1 SHEETS STA. 765+00.00 TO STA. 109+00.00

F.A.I. RTE.	SECTION	COUNTY	TOTAL SHEETS	SHEET NO.
55	(57-1,57-2)BD5	MCLEAN	88	15
CONTRACT NO. 70D64				
ILLINOIS FED. AID PROJECT				



IF WORKING ON CONCURRENT STRUCTURES, DRUMS WITH STEADY BURN MONODIRECTIONAL LIGHTS AT 100' CENTERS SHALL BE USED PER HIGHWAY STANDARD 701402. ONLY DRUMS ALONG THE LANE SHIFTS AND 500' IN ADVANCE OF THE LANE SHIFTS WILL REQUIRE MONODIRECTIONAL LIGHTS. OTHER DRUMS ALONG THE TANGENT BETWEEN STRUCTURES WILL NOT REQUIRE LIGHTS. CHECK BARRICADES WILL BE REQUIRED EVERY 1000'. COST INCLUDED WITH TRAFFIC CONTROL AND PROTECTION STANDARD 701402.

**TEMPORARY CONCRETE BARRIER LAYOUT - STAGE I**  
**S.N. 057-0153 (NB) & S.N. 057-0152 (SB)**

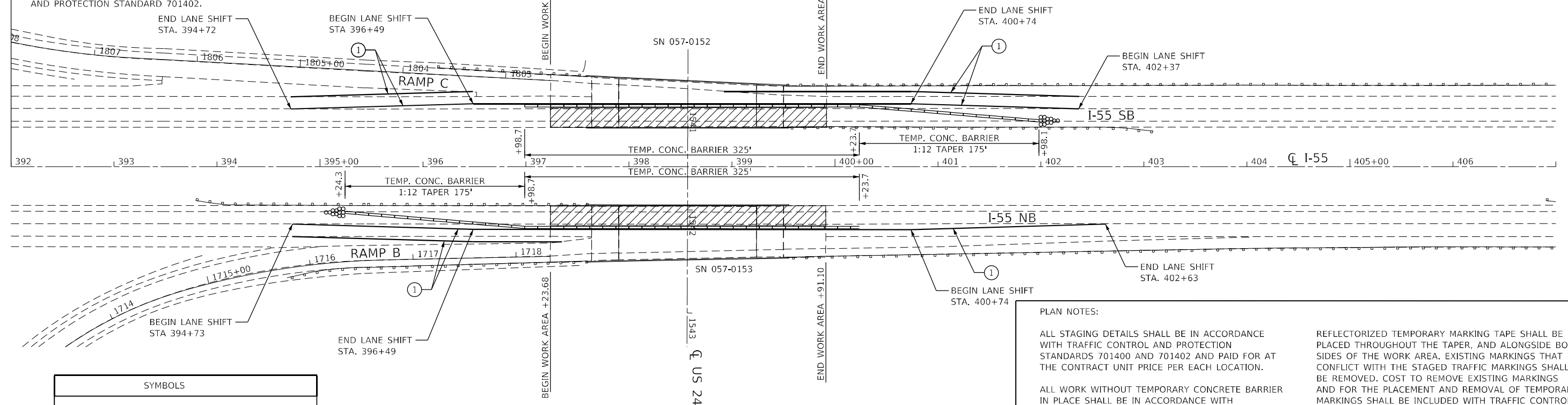
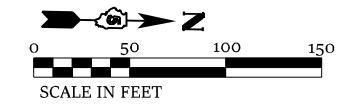

SYMBOLS	
	TEMPORARY CONCRETE BARRIER
	IMPACT ATTENUATOR
	WORK AREA
	TEMPORARY PAVEMENT MARKINGS

**PLAN NOTES:**

ALL STAGING DETAILS SHALL BE IN ACCORDANCE WITH TRAFFIC CONTROL AND PROTECTION STANDARDS 701400 AND 701402 AND PAID FOR AT THE CONTRACT UNIT PRICE PER EACH LOCATION.

ALL WORK WITHOUT TEMPORARY CONCRETE BARRIER IN PLACE SHALL BE IN ACCORDANCE WITH TRAFFIC CONTROL AND PROTECTION STANDARDS 701400 AND 701401.

FOR ADDITIONAL DETAILS ASSOCIATED WITH TEMPORARY CONCRETE BARRIER, SEE TRAFFIC CONTROL AND PROTECTION STANDARD 704001.

VERTICAL PANELS WITH LIGHTS AND REFLECTORS SHALL BE ATTACHED AT 25 FOOT CENTERS TO THE BARRIER WALL AND GUARDRAIL. COST INCLUDED WITH TRAFFIC CONTROL AND PROTECTION STANDARD 701402.

REFLECTORIZED TEMPORARY MARKING TAPE SHALL BE PLACED THROUGHOUT THE TAPER, AND ALONGSIDE BOTH SIDES OF THE WORK AREA. EXISTING MARKINGS THAT CONFLICT WITH THE STAGED TRAFFIC MARKINGS SHALL BE REMOVED. COST TO REMOVE EXISTING MARKINGS AND FOR THE PLACEMENT AND REMOVAL OF TEMPORARY MARKINGS SHALL BE INCLUDED WITH TRAFFIC CONTROL AND PROTECTION STANDARD 701402.

PRIOR TO ROUTING TRAFFIC ONTO THE SHOULDERS, THE CONTRACTOR SHALL SECURE ANY GRATES ON SHOULDER INLETS AS DIRECTED BY THE ENGINEER. THIS WORK SHALL BE PAID FOR ACCORDING TO ARTICLE 109.04 OF THE STANDAR SPECIFICATIONS.

PORTABLE CHANGEABLE MESSAGE SIGNS ARE REQUIRED SEVEN DAYS PRIOR TO CONSTRUCTION. THE RESIDENT ENGINEER OR TRAFFIC CONTROL SUPERVISOR SHALL PROVIDE AN APPROPRIATE MESSAGE.

**TEMPORARY CONCRETE BARRIER LAYOUT - STAGE II**  
**S.N. 057-0153 (NB) & S.N. 057-0152 (SB)**

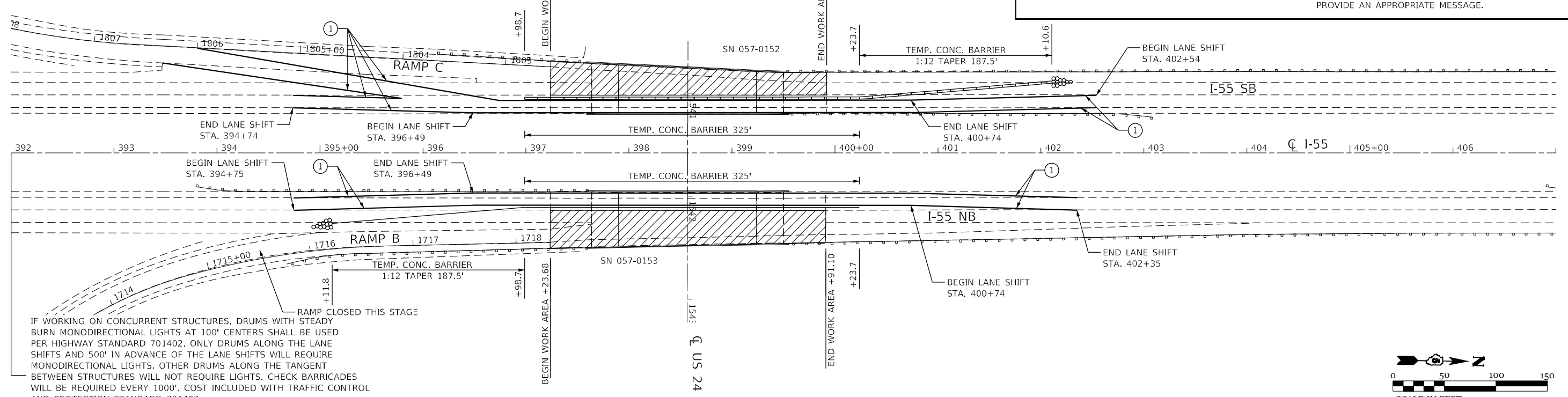

IF WORKING ON CONCURRENT STRUCTURES, DRUMS WITH STEADY BURN MONODIRECTIONAL LIGHTS AT 100' CENTERS SHALL BE USED PER HIGHWAY STANDARD 701402. ONLY DRUMS ALONG THE LANE SHIFTS AND 500' IN ADVANCE OF THE LANE SHIFTS WILL REQUIRE MONODIRECTIONAL LIGHTS. OTHER DRUMS ALONG THE TANGENT BETWEEN STRUCTURES WILL NOT REQUIRE LIGHTS. CHECK BARRICADES WILL BE REQUIRED EVERY 1000'. COST INCLUDED WITH TRAFFIC CONTROL AND PROTECTION STANDARD 701402.

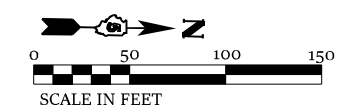

MODEL: D:\2021\12\_Plan16 FILE NAME: P:\EIT\m303454...\_PTB\_1801.DWG Order #6\Cardi\Sheet\05702664.dwg Stationing: 3\_0152-0153.dwg



USER NAME = rhanland	DESIGNED - WMK	REVISED -
	DRAWN - DMM	REVISED -
PLOT SCALE = 100,000' / in.	CHECKED - RLH	REVISED -
PLOT DATE = 10/21/2021	DATE - 10/21/2021	REVISED -

**STATE OF ILLINOIS DEPARTMENT OF TRANSPORTATION**

**TEMPORARY CONCRETE BARRIER LAYOUT**  
**S.N. 057-0152 SB & S.N. 057-0153 NB**  
 SCALE: 100,000' / in SHEET 1 OF 1 SHEETS STA. 379+00.00 TO STA. 409+00.00

F.A.I. RTE.	SECTION	COUNTY	TOTAL SHEETS	SHEET NO.
55	(57-1,57-2)BD5	MCLEAN	88	16
CONTRACT NO. 70D64			ILLINOIS FED. AID PROJECT	

IF WORKING ON CONCURRENT STRUCTURES, DRUMS WITH STEADY BURN MONODIRECTIONAL LIGHTS AT 100' CENTERS SHALL BE USED PER HIGHWAY STANDARD 701402. ONLY DRUMS ALONG THE LANE SHIFTS AND 500' IN ADVANCE OF THE LANE SHIFTS WILL REQUIRE MONODIRECTIONAL LIGHTS. OTHER DRUMS ALONG THE TANGENT BETWEEN STRUCTURES WILL NOT REQUIRE LIGHTS. CHECK BARRICADES WILL BE REQUIRED EVERY 1000'. COST INCLUDED WITH TRAFFIC CONTROL AND PROTECTION STANDARD 701402.

**TEMPORARY CONCRETE BARRIER LAYOUT - STAGE I**  
**S.N. 057-0179 (NB) & S.N. 057-0178 (SB)**

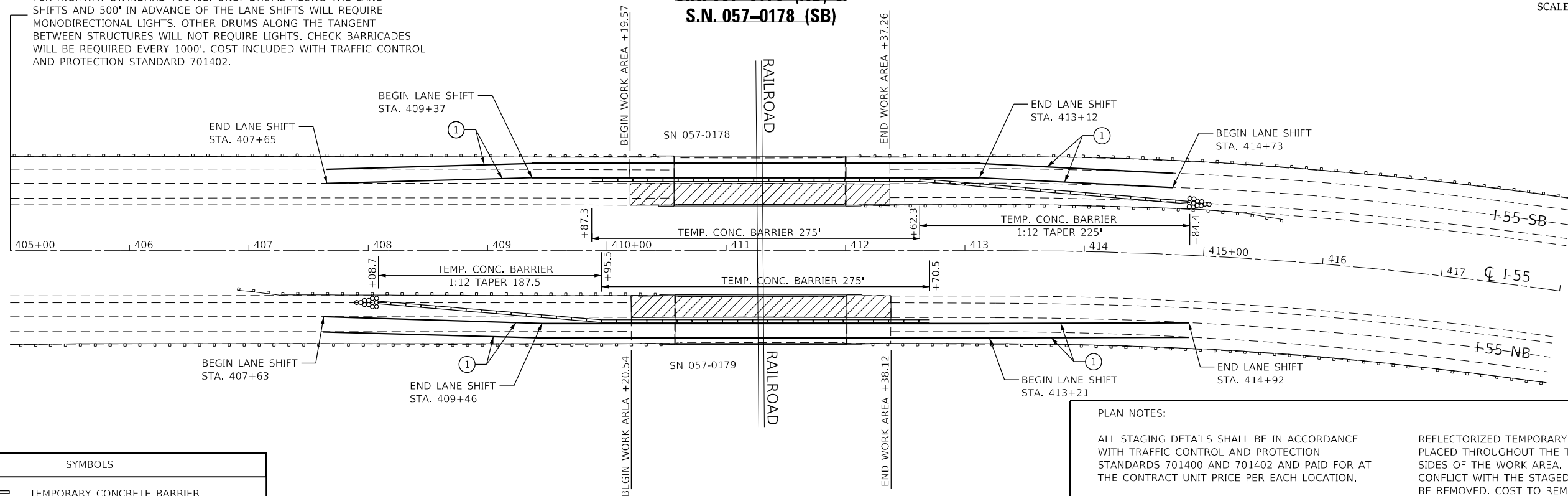
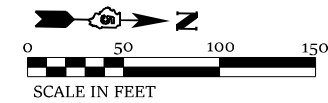

SYMBOLS	
	TEMPORARY CONCRETE BARRIER
	IMPACT ATTENUATOR
	WORK AREA
	TEMPORARY PAVEMENT MARKINGS

**PLAN NOTES:**

ALL STAGING DETAILS SHALL BE IN ACCORDANCE WITH TRAFFIC CONTROL AND PROTECTION STANDARDS 701400 AND 701402 AND PAID FOR AT THE CONTRACT UNIT PRICE PER EACH LOCATION.

ALL WORK WITHOUT TEMPORARY CONCRETE BARRIER IN PLACE SHALL BE IN ACCORDANCE WITH TRAFFIC CONTROL AND PROTECTION STANDARDS 701400 AND 701401.

FOR ADDITIONAL DETAILS ASSOCIATED WITH TEMPORARY CONCRETE BARRIER, SEE TRAFFIC CONTROL AND PROTECTION STANDARD 704001.

VERTICAL PANELS WITH LIGHTS AND REFLECTORS SHALL BE ATTACHED AT 25 FOOT CENTERS TO THE BARRIER WALL AND GUARDRAIL. COST INCLUDED WITH TRAFFIC CONTROL AND PROTECTION STANDARD 701402.

REFLECTORIZED TEMPORARY MARKING TAPE SHALL BE PLACED THROUGHOUT THE TAPER, AND ALONGSIDE BOTH SIDES OF THE WORK AREA. EXISTING MARKINGS THAT CONFLICT WITH THE STAGED TRAFFIC MARKINGS SHALL BE REMOVED. COST TO REMOVE EXISTING MARKINGS AND FOR THE PLACEMENT AND REMOVAL OF TEMPORARY MARKINGS SHALL BE INCLUDED WITH TRAFFIC CONTROL AND PROTECTION STANDARD 701402.

PRIOR TO ROUTING TRAFFIC ONTO THE SHOULDERS, THE CONTRACTOR SHALL SECURE ANY GRATES ON SHOULDER INLETS AS DIRECTED BY THE ENGINEER. THIS WORK SHALL BE PAID FOR ACCORDING TO ARTICLE 109.04 OF THE STANDAR SPECIFICATIONS.

PORTABLE CHANGEABLE MESSAGE SIGNS ARE REQUIRED SEVEN DAYS PRIOR TO CONSTRUCTION. THE RESIDENT ENGINEER OR TRAFFIC CONTROL SUPERVISOR SHALL PROVIDE AN APPROPRIATE MESSAGE.

**TEMPORARY CONCRETE BARRIER LAYOUT - STAGE II**  
**S.N. 057-0179 (NB) & S.N. 057-0178 (SB)**

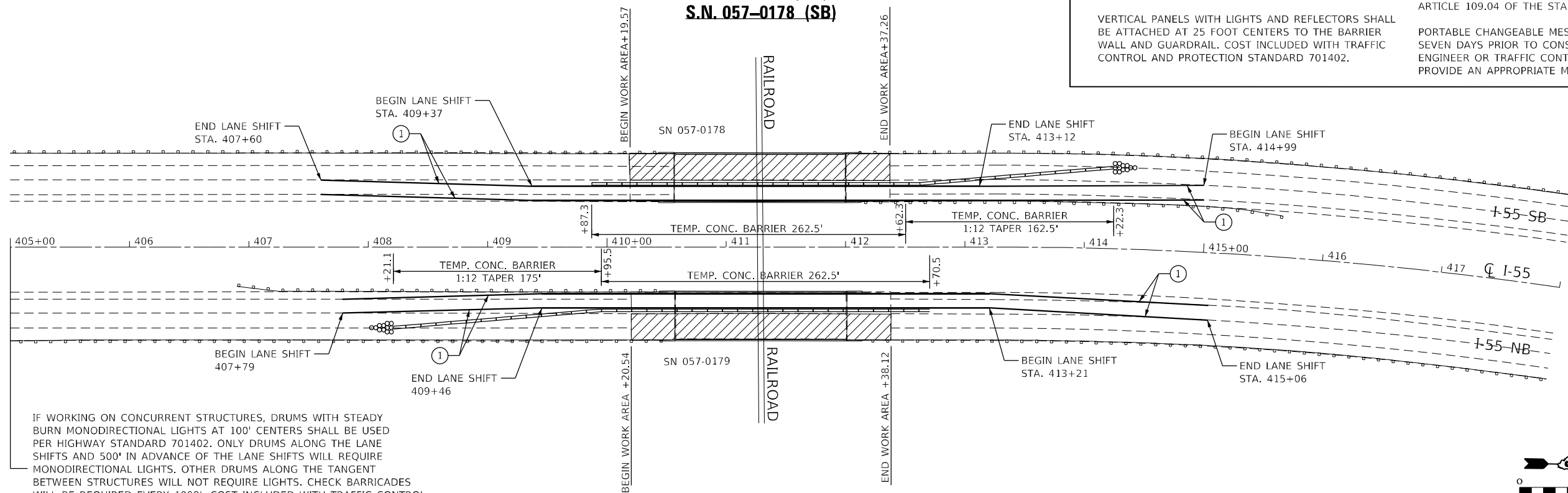

IF WORKING ON CONCURRENT STRUCTURES, DRUMS WITH STEADY BURN MONODIRECTIONAL LIGHTS AT 100' CENTERS SHALL BE USED PER HIGHWAY STANDARD 701402. ONLY DRUMS ALONG THE LANE SHIFTS AND 500' IN ADVANCE OF THE LANE SHIFTS WILL REQUIRE MONODIRECTIONAL LIGHTS. OTHER DRUMS ALONG THE TANGENT BETWEEN STRUCTURES WILL NOT REQUIRE LIGHTS. CHECK BARRICADES WILL BE REQUIRED EVERY 1000'. COST INCLUDED WITH TRAFFIC CONTROL AND PROTECTION STANDARD 701402.

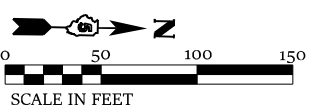

MODEL: D:\2021\12\_Plan17 FILE NAME: P:\EIT\m30454 - PTB 1801.DOT.DS V:\Work Order #6\RoadSheet\0570664.ctb Stationing\_4\_0178-0179.dgn



USER NAME = rhanland	DESIGNED - WMK	REVISED -
	DRAWN - DMM	REVISED -
PLOT SCALE = 100.0000' / in.	CHECKED - RLH	REVISED -
PLOT DATE = 10/21/2021	DATE - 10/21/2021	REVISED -

**STATE OF ILLINOIS DEPARTMENT OF TRANSPORTATION**

**TEMPORARY CONCRETE BARRIER LAYOUT**  
**S.N. 057-0178 SB & S.N. 057-0179 NB**  
 SCALE: 100.0000' / in SHEET 1 OF 1 SHEETS STA. 705+00.00 TO STA. 735+00.00

F.A.I. RTE. 55	SECTION (57-1,57-2)BDS	COUNTY MCLEAN	TOTAL SHEETS 88	SHEET NO. 17
CONTRACT NO. 70D64			ILLINOIS FED. AID PROJECT	

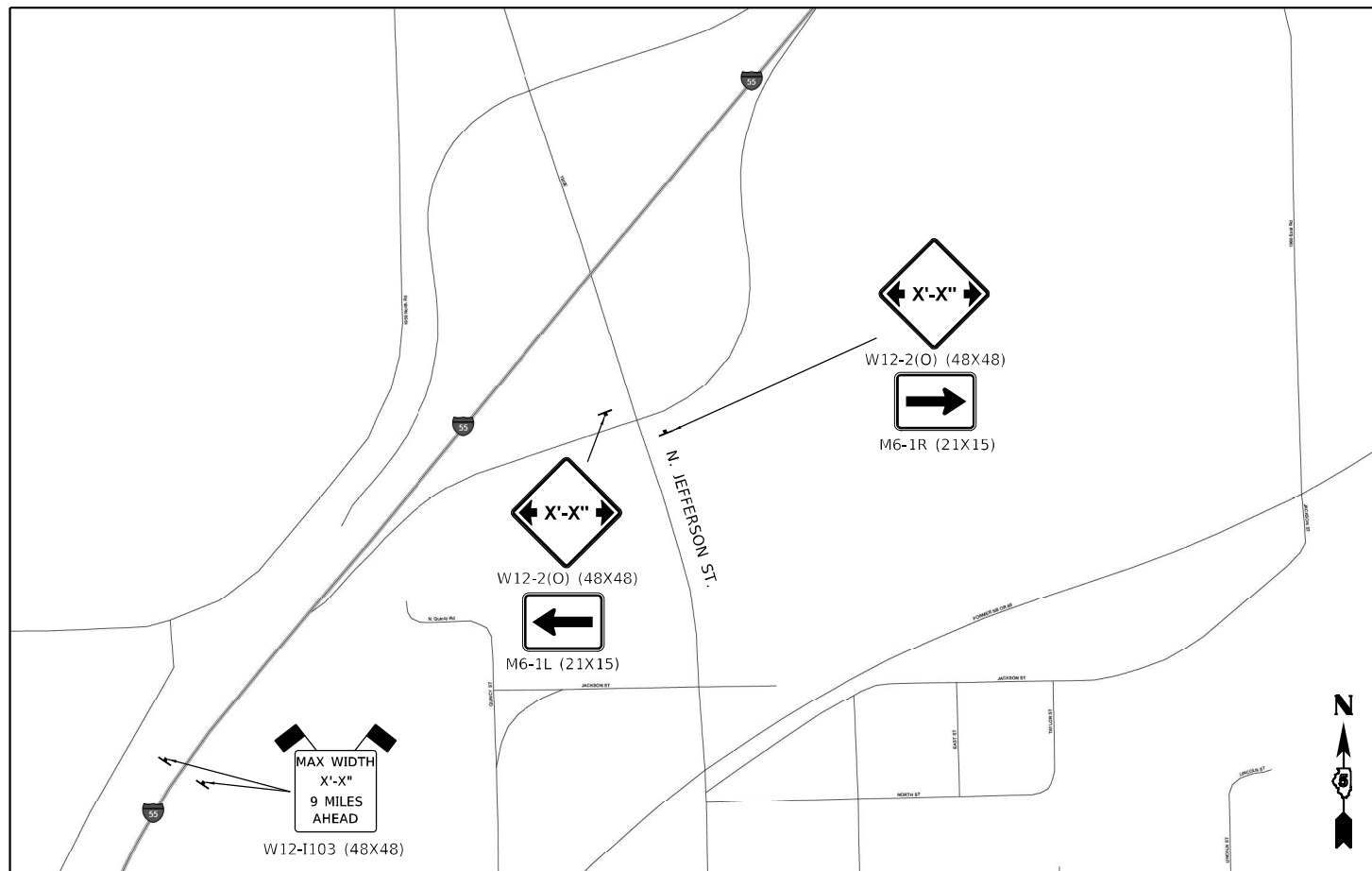

TOWANDA DETAIL

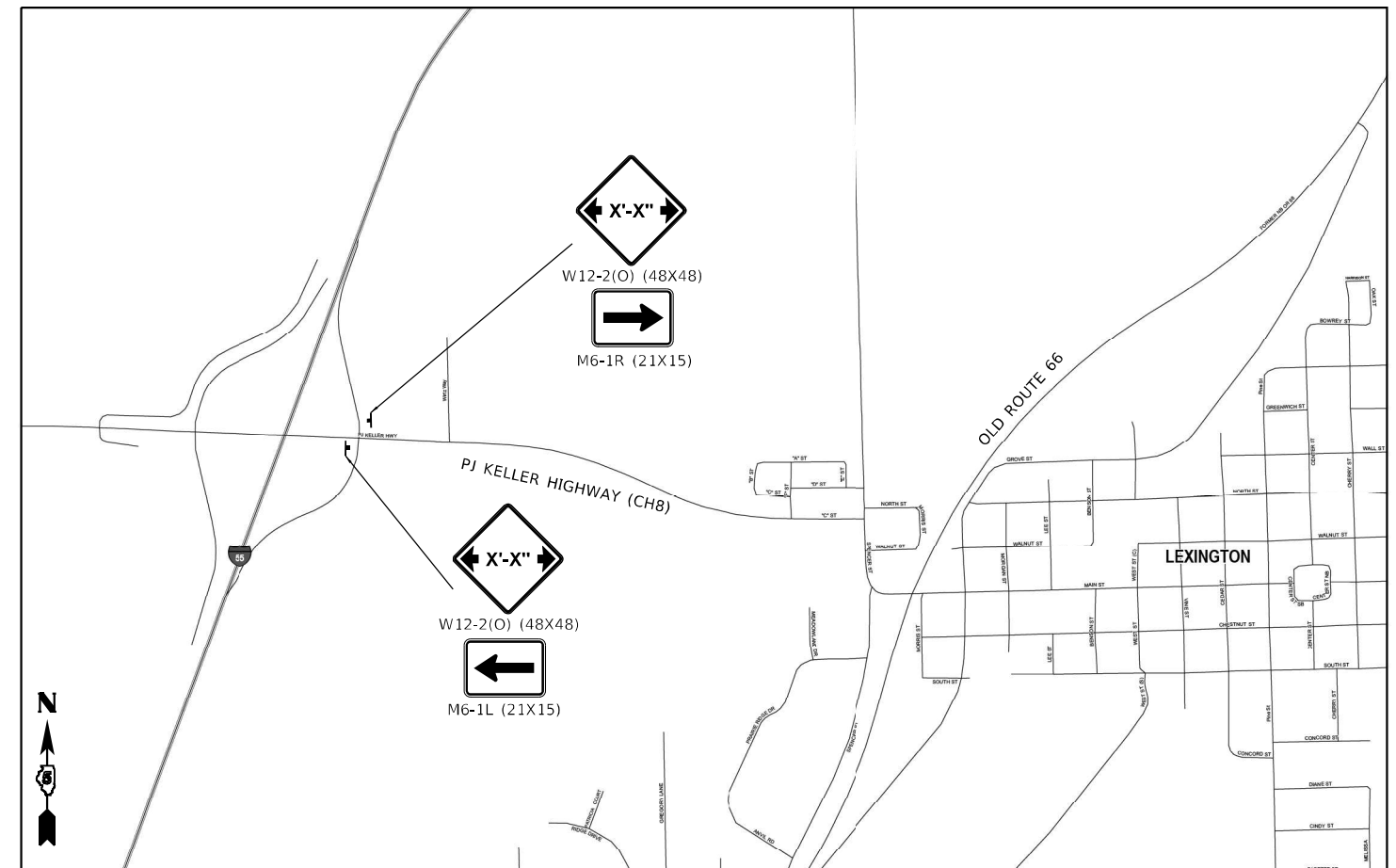

LEXINGTON DETAIL

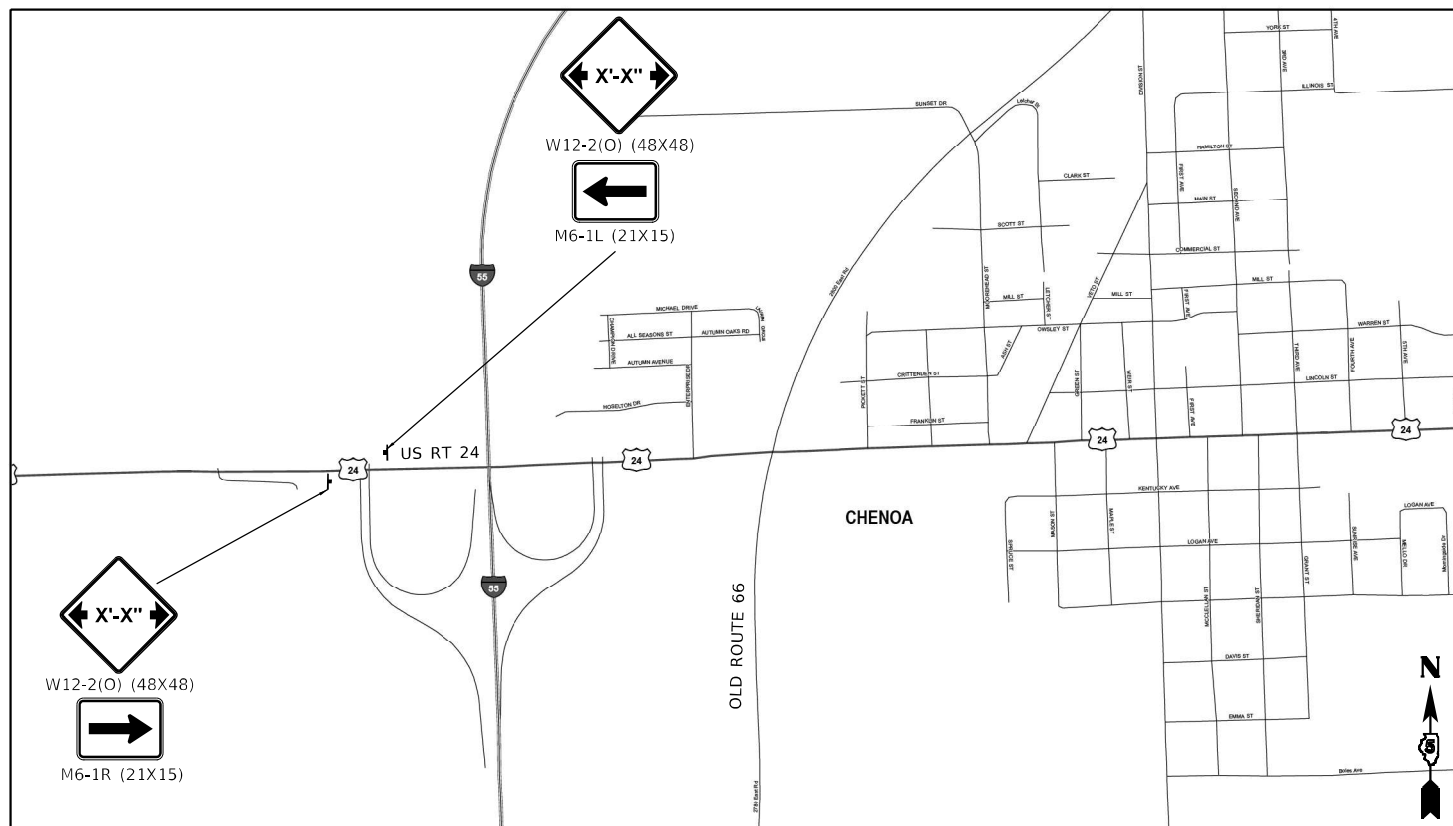

CHENOA DETAIL

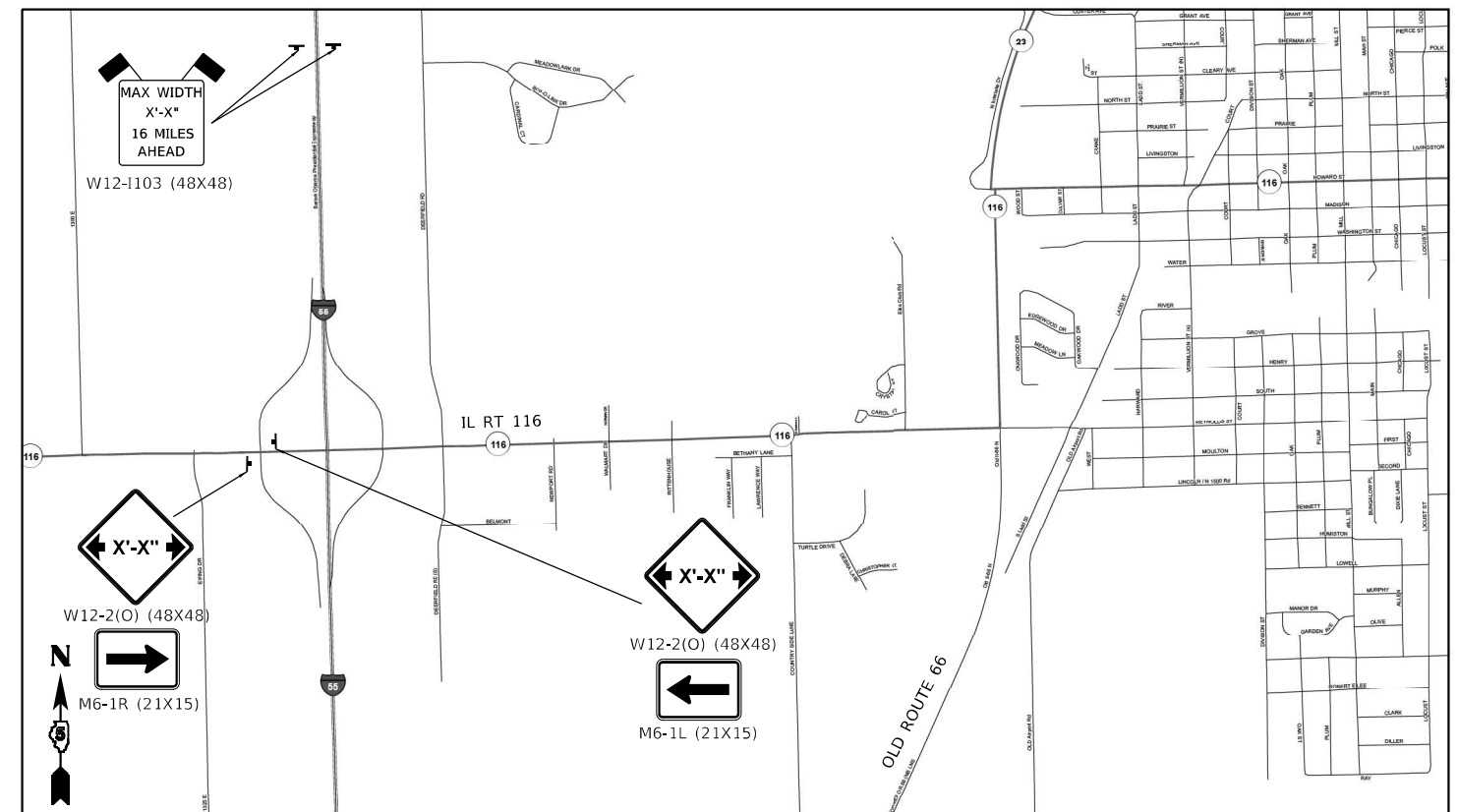

PONTIAC DETAIL

MODEL: D:\cadd\116\116.dwg; FILE NAME: P:\Effingham\116\116.dwg; ORDER: #604001; SHEET: 057-0183-0182-0174-0173; WIDTH RESTRICTION\_SIGNING



CIVIL DESIGN, INC.  
WBE / DBE  
EFFINGHAM, IL  
LICENSE # 184.003222

USER NAME	= rhanland
PLOT SCALE	= 1/8" = 1'-0"
PLOT DATE	= 10/21/2021

DESIGNED	- WMK
DRAWN	- DMM
CHECKED	- RLH
DATE	- 10/21/2021

REVISED	-
REVISED	-
REVISED	-
REVISED	-

STATE OF ILLINOIS  
DEPARTMENT OF TRANSPORTATION

I-55 MAINTENANCE OF TRAFFIC WIDTH RESTRICTION SIGNING DETAILS	
SCALE: 1/8" = 1'-0"	116 SHEET 1 OF 2 SHEETS STA. TO STA.

F.A.I. RTE.	SECTION	COUNTY	TOTAL SHEETS	SHEET NO.
55	(57-1,57-2)BD5	MCLEAN	88	18
CONTRACT NO. 70D64				
ILLINOIS FED. AID PROJECT				

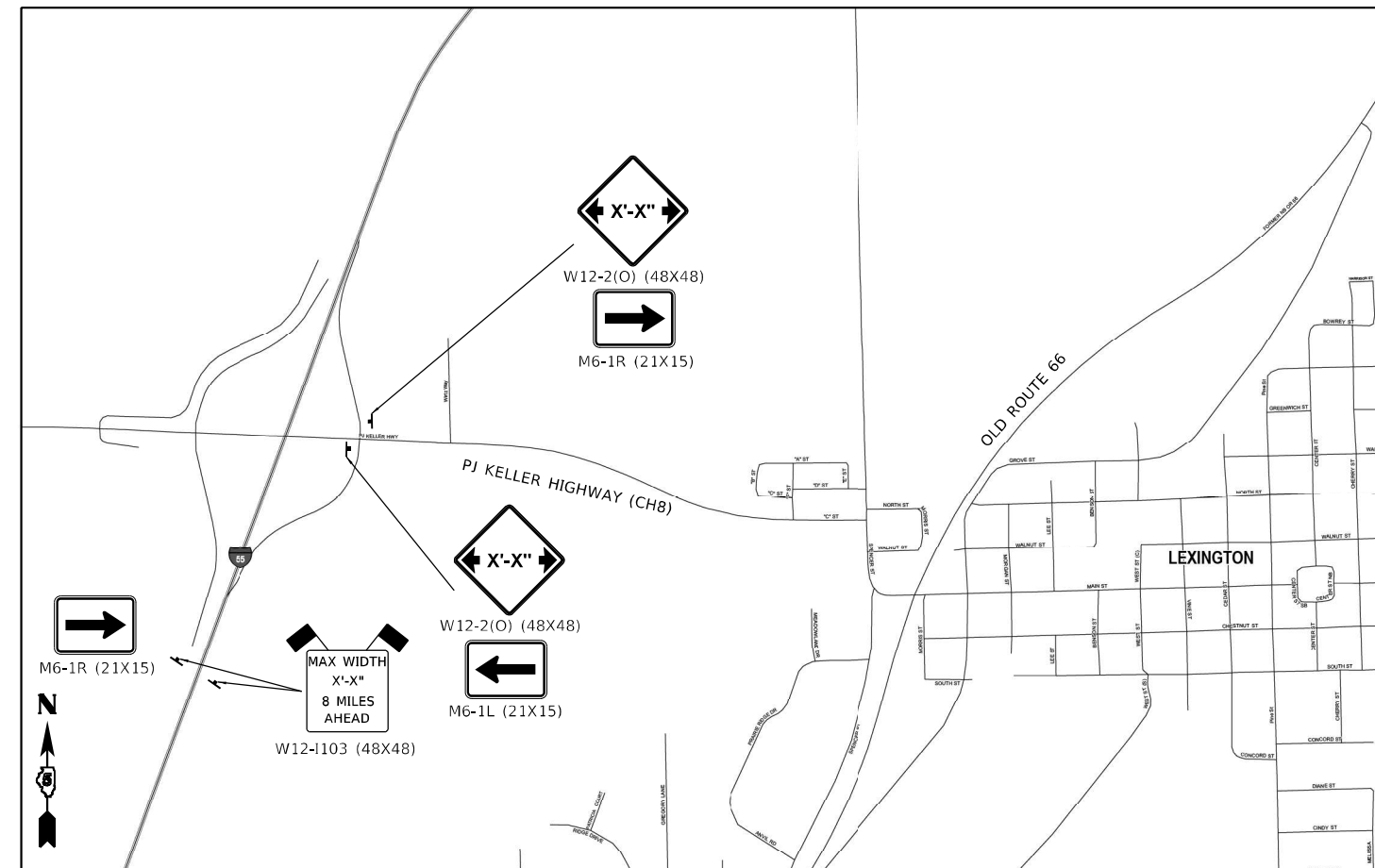

LEXINGTON DETAIL

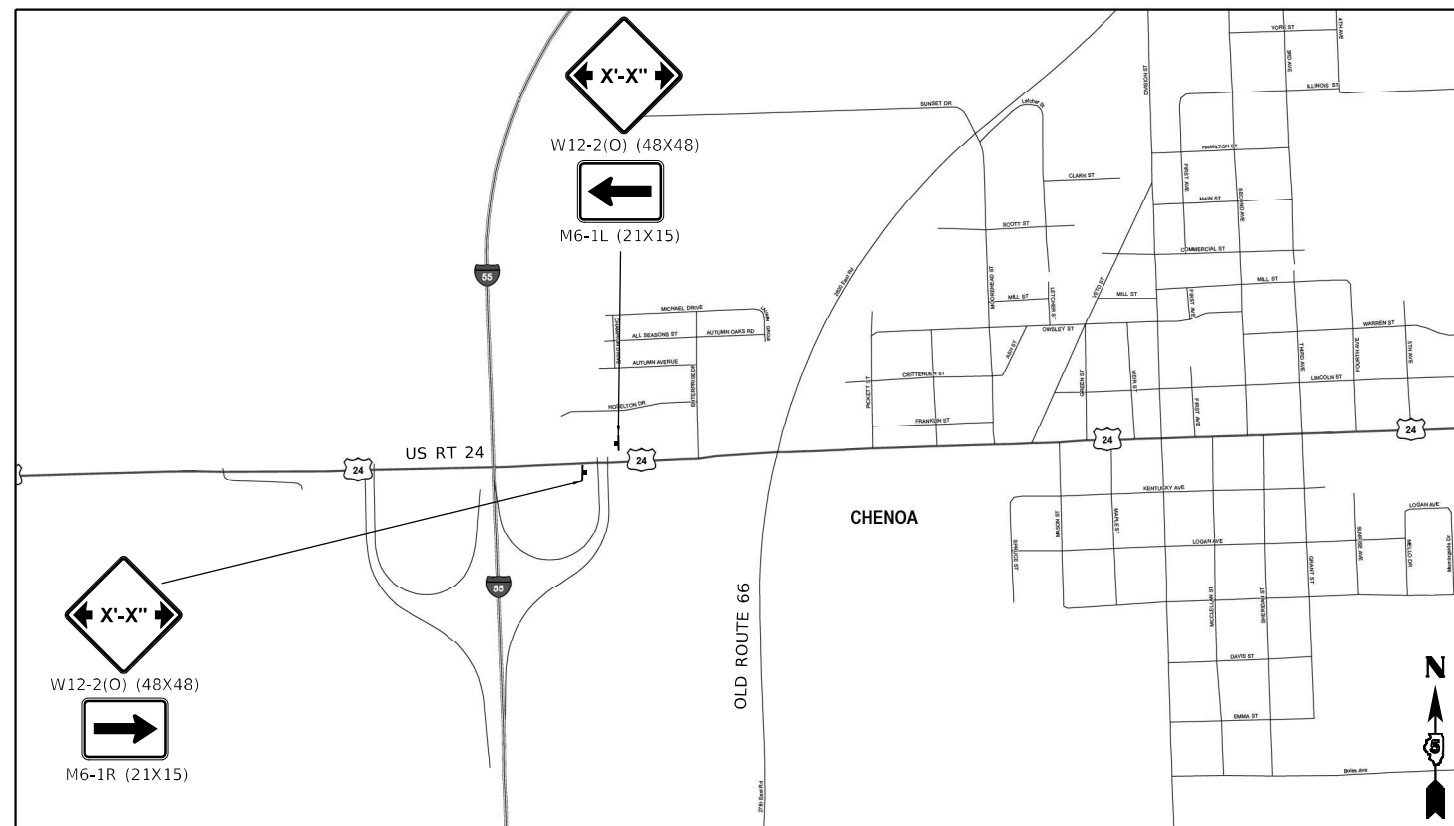

CHENOA DETAIL

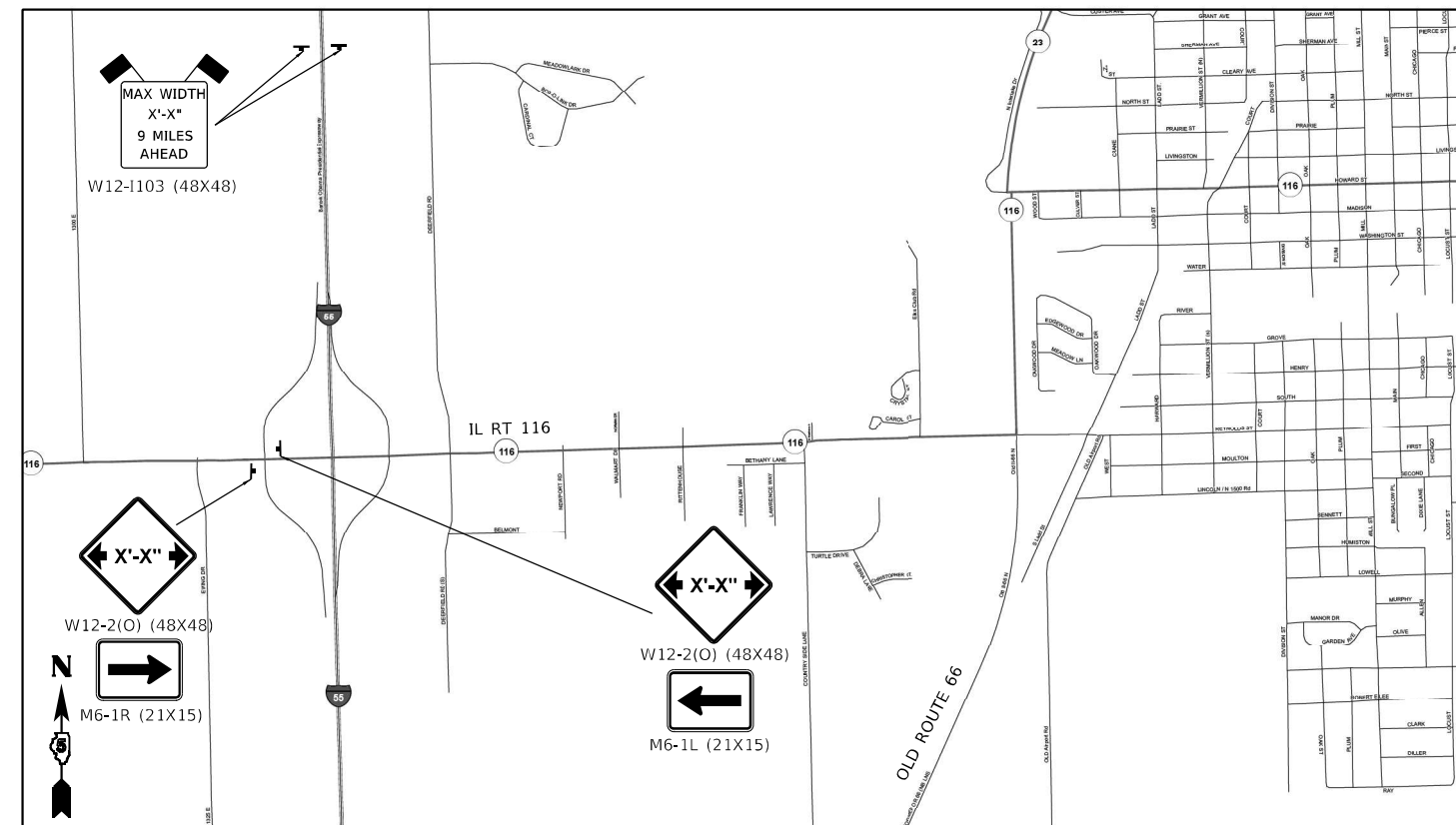

PONTIAC DETAIL

MODEL: D:\cadd\11\1101\DOT\_DS\_V\Work\Order #6\cadd\Sheet\0570064-ht-detailed-widthrestriction\_2.dgn  
 FILE NAME: P:\Effingham\1101\DOT\_DS\_V\Work\Order #6\cadd\Sheet\0570064-ht-detailed-widthrestriction\_2.dgn



CIVIL DESIGN, INC.  
 WBE / DBE  
 EFFINGHAM, IL  
 LICENSE # 184.003222

USER NAME	= rhanland
PLOT SCALE	= 15840,0000' / in.
PLOT DATE	= 10/21/2021

DESIGNED	- WMK
DRAWN	- DMM
CHECKED	- RLH
DATE	- 10/21/2021

REVISED	-
REVISED	-
REVISED	-
REVISED	-

STATE OF ILLINOIS  
 DEPARTMENT OF TRANSPORTATION

I-55 MAINTENANCE OF TRAFFIC WIDTH RESTRICTION SIGNING DETAILS	
SCALE: 15840,000' / in	SHEET 2 OF 2 SHEETS
STA.	TO STA.

F.A.I. RTE.	SECTION	COUNTY	TOTAL SHEETS	SHEET NO.
55	(57-1,57-2)BD5	MCLEAN	88	19
CONTRACT NO. 70D64				
ILLINOIS FED. AID PROJECT				

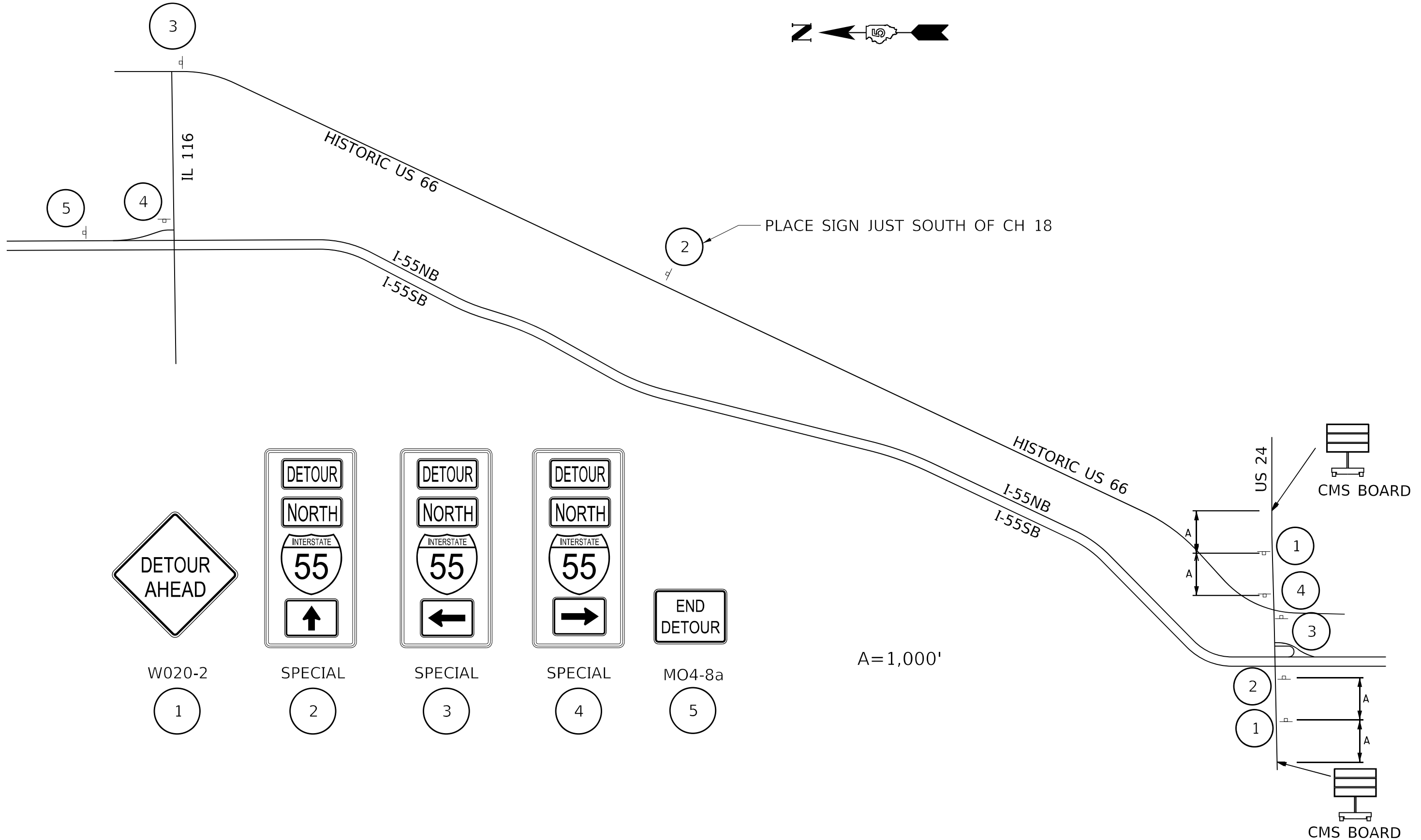

W020-2

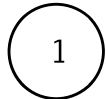

SPECIAL

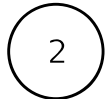

SPECIAL

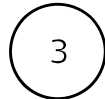

SPECIAL

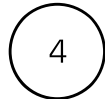

MO4-8a



A=1,000'

MODEL: D:\cadd\11\11\DOT\_DS\_V\Work\Order #6\Cadd\Sheet\0570D64\_ch1\_Detour.at US 24\_Rp\_B.cgm  
FILE NAME: P:\Effingham\11454 - PTB 1801.DOT\_DS\_V\Work\Order #6\Cadd\Sheet\0570D64\_ch1\_Detour.at US 24\_Rp\_B.cgm



**CIVIL DESIGN, INC.**  
WBE / DBE  
EFFINGHAM, IL  
LICENSE # 184.003222

USER NAME	= rhanfland
PLOT SCALE	= 500.0000' / in.
PLOT DATE	= 10/21/2021

DESIGNED	- WMK
DRAWN	- DMM
CHECKED	- RLH
DATE	- 10/21/2021

REVISED	-
REVISED	-
REVISED	-
REVISED	-

**STATE OF ILLINOIS  
DEPARTMENT OF TRANSPORTATION**

**DETOUR I-55 AT US 24 RAMP B**

SCALE: 500.0000' / in. SHEET 1 OF 1 SHEETS STA. TO STA.

F.A.I. RTE.	SECTION	COUNTY	TOTAL SHEETS	SHEET NO.
55	(57-1,57-2)BD5	MCLEAN	88	20
CONTRACT NO. 70D64				
ILLINOIS FED. AID PROJECT				

Structure 057-0152 was originally constructed in 1977 as FAI 55, Contract 29202, Section 57-1HB at Station 398+57.00 in McLean County. In 2003, the structure received repairs with Contract 66107, Section (57-1, 57-2) RS. The bituminous overlay and waterproofing membrane were removed and deck received a 2 1/4" microsilica concrete overlay. The abutment expansion joints were replaced with silicone joint sealer in a poly concrete nosing. The expansion bearings were replaced with elastomeric bearings. Existing floor drains were plugged. The approach slabs were removed and replaced. The beams were painted in August 2011.

The existing structure is a two span steel continuous multi beam bridge. The superstructure consists of eight 36" WF steel girder supporting a nominal 7 1/4" thick RC deck with a 2 1/4" microsilica concrete wearing surface. The superstructure is supported by a single trapezoidal column pier on a spread footing and two vaulted abutments on concrete piles. The approach spans are supported by six 36" PPC I-beams.

The structure has an overall length of 187'-5" from back to back of approach bents. The deck has an out to out width that varies from 42'-0" to 51'-0", and a deck (clear area) width that varies from 38'-6" to 47'-6" base to base of curb.

Note:  
See Sheet 3 of 26 for Proposed Work, Bill of Material, and General Notes.

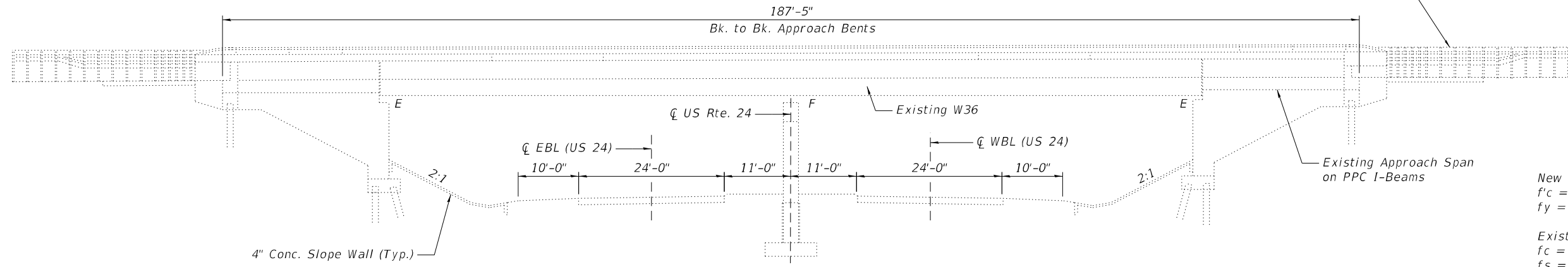
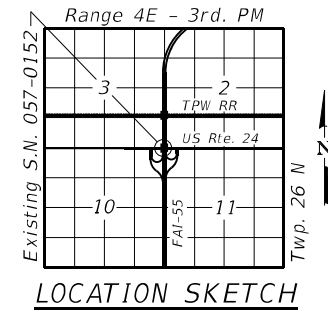

ELEVATION

**DESIGN STRESSES**  
**FIELD UNITS**

**New Construction**  
f'c = 4,000 psi  
fy = 60,000 psi (Reinforcement)

**Existing Structure**  
f'c = 1,200 psi  
fs = 20,000 psi (Reinforcement)  
fs = 20,000 psi (Structural Steel)  
f'c = 5,000 psi (PPC I-Beams)

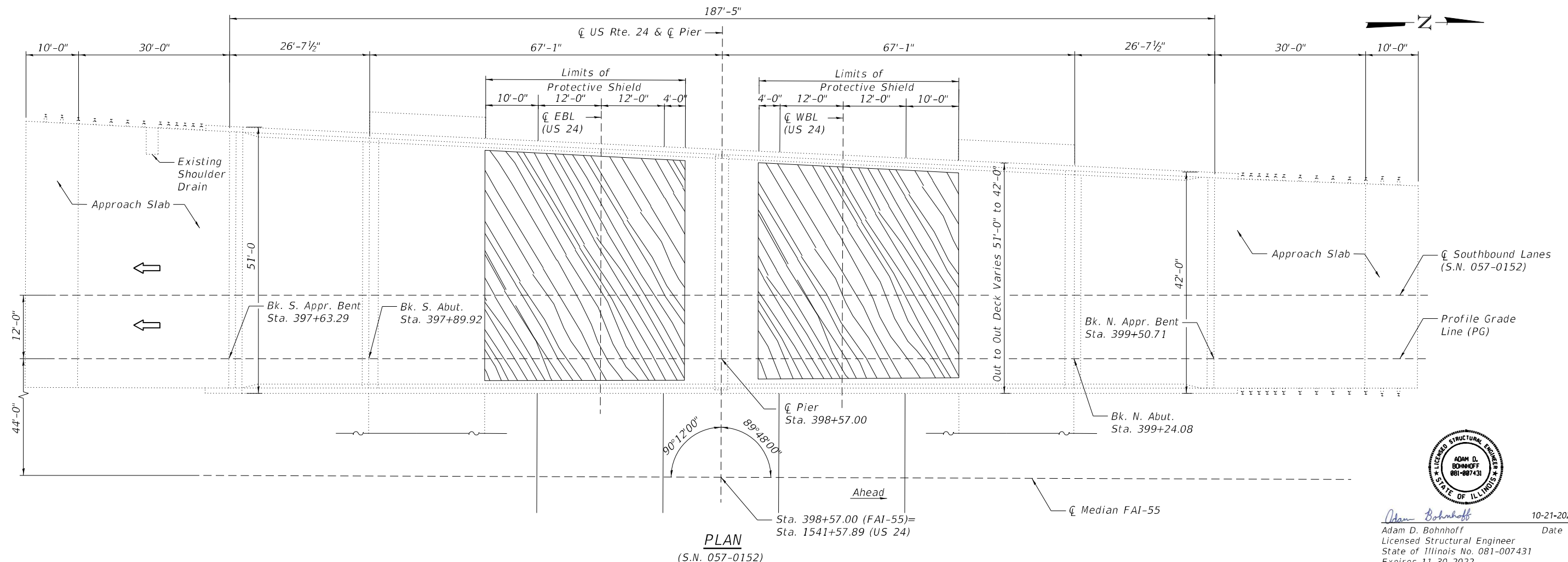

PLAN  
(S.N. 057-0152)



Adam Bohnhoff  
Adam D. Bohnhoff  
Licensed Structural Engineer  
State of Illinois No. 081-007431  
Expires 11-30-2022  
Date 10-21-2021

MODEL: GPE  
FILE NAME: P:\Effingham\3454 - PTB 189 IDOT D5 V-VI\Work Order #6\Cadd\Sheet\152 & 153\152\0570152\_0152\_0153\_Combined.dgn  
10/21/2021 2:52:19 PM



CIVIL DESIGN, INC.  
WBE / DBE  
EFFINGHAM, IL  
LICENSE # 184.003222

USER NAME =	DESIGNED - KAS	REVISED -
PLOT SCALE =	CHECKED - TJZ	REVISED -
PLOT DATE =	DRAWN - DWS	REVISED -
	CHECKED - KAS	REVISED -

STATE OF ILLINOIS  
DEPARTMENT OF TRANSPORTATION

GENERAL PLAN AND ELEVATION  
S.N. 057-0152 (SB)

SHEET 1 OF 26 SHEETS

F.A.I. RTE.	SECTION	COUNTY	TOTAL SHEETS	SHEET NO.
55	(57-1,57-2)BDS	MCLEAN	88	21
CONTRACT NO. 70D64			ILLINOIS FED. AID PROJECT	

Structure 057-0153 was originally constructed in 1977 as FAI 55, Contract 29202, Section 57-1HB at Station 398+57.00 in McLean County. In 2003, the structure received repairs with Contract 66107, Section (57-1, 57-2) RS. The bituminous overlay and waterproofing membrane were removed and deck received a 2 1/4" microsilica concrete overlay. The abutment expansion joints were replaced with silicone joint sealer in a poly concrete nosing. The expansion bearings were replaced with elastomeric bearings. Existing floor drains were plugged. The approach slabs were removed and replaced. The beams were painted in August 2011.

The existing structure is a two span steel continuous multi beam bridge. The superstructure consists of nine 36" WF steel girder supporting a nominal 7 1/4" thick RC deck with a 2 1/4" microsilica concrete wearing surface. The superstructure is supported by a single trapezoidal column pier on a spread footing and two vaulted abutments on concrete piles. The approach spans are supported by six 36" PPC I-beams.

The structure has an overall length of 187'-5" from back to back of approach bents. The deck has an out to out width that varies from 52'-3" to 56'-0", and a deck (clear area) width that varies from 48'-9" to 52'-6" base to base of curb.

Note:  
See Sheet 3 of 26 for Proposed Work, Bill of Material, and General Notes.

Traffic Barrier Terminal Type 6 Guardrail (Typ.)  
Remove and Re-erect if needed  
to complete hydrodemolition

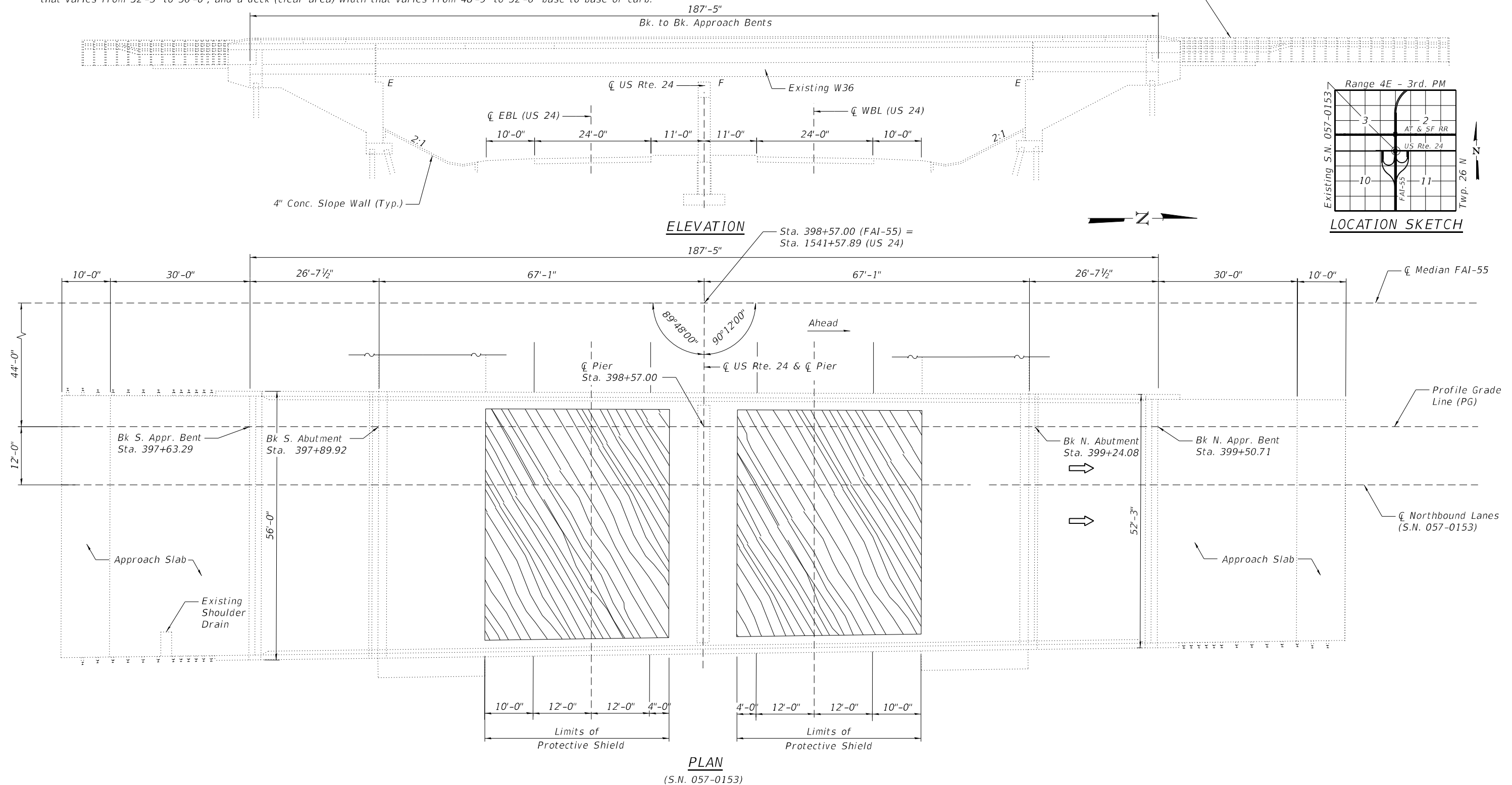

MODEL: GPEZ  
FILE NAME: P:\Effingham\3454 - PTB 189 IDOT D5 V-V\Work Order #6\Cadd\Sheet\152 & 153\DOTD570D64\_0152\_0153\_Combined.dgn



USER NAME =	DESIGNED - KAS	REVISED -
	CHECKED - TJZ	REVISED -
PLOT SCALE =	DRAWN - DWS	REVISED -
PLOT DATE =	CHECKED - KAS	REVISED -

STATE OF ILLINOIS  
DEPARTMENT OF TRANSPORTATION

GENERAL PLAN AND ELEVATION  
S.N. 057-0153 (NB)

SHEET 2 OF 26 SHEETS

F.A.I. RTE.	SECTION	COUNTY	TOTAL SHEETS	SHEET NO.
55	(57-1,57-2)BDS	MCLEAN	88	22
			CONTRACT NO. 70D64	
		ILLINOIS FED. AID PROJECT		

TOTAL BILL OF MATERIAL SN 057-0152 & SN 057-0153

Item	Unit	Total
Protective Coat	Sq. Yd.	3259
Concrete Removal	Cu. Yd.	98.8
Protective Shield	Sq. Yd.	748
Floor Drains	Each	8
Concrete Structures	Cu. Yd.	35.9
Concrete Superstructure	Cu. Yd.	72.0
Furnishing and Erecting Structural Steel	Pound	8190
Stud Shear Connectors	Each	594
Reinforcement Bars, Epoxy Coated	Pound	20100
Bar Splicers	Each	136
Preformed Joint Seal 1"	Foot	195
Preformed Joint Strip Seal	Foot	197
Bridge Deck Grooving (Longitudinal)	Sq. Yd.	2077
Structural Steel Removal	Pound	8190
Structural Steel Repair	Pound	6880
Bridge Deck Latex Concrete Overlay, 2 1/4"	Sq. Yd.	860
Bridge Deck Latex Concrete Overlay, 3"	Sq. Yd.	1754
Bridge Deck Scarification 2"	Sq. Yd.	860
Bridge Deck Scarification 2 3/4"	Sq. Yd.	1754
Structural Repair of Concrete (Depth Equal to or Less than 5")	Sq. Ft.	1226
Deck Slab Repair (Full Depth, Type I)	Sq. Yd.	62
Deck Slab Repair (Full Depth, Type II)	Sq. Yd.	4
Diamond Grinding (Bridge Section)	Sq. Yd.	2607

PROPOSED WORK

1. Perform Bridge Deck Scarification on Bridge Deck, Approach Slabs, and PCC Connectors.
2. Removal of Deck Ends and Parapet at Deck Ends.
3. Removal of Existing Joints.
4. Perform Beam End Repairs and Diaphragm Replacement.
5. Perform Full-Depth Patching.
6. Place New Floor Drains.
7. Pour Deck Ends.
8. Insert Rubber Strip Seal into Locking Edge Rails.
9. Pour Parapets.
10. Replace Joints at Approach Ends.
11. Place Latex Concrete Overlay on Bridge Deck, Approach Slabs, and PCC Connectors.
12. Perform Diamond Grinding and Longitudinal Deck Grooving.
13. Perform Substructure Repairs.
14. Apply Protective Coat.

GENERAL NOTES

Plan dimensions and details relative to the existing structure have been taken from existing plans and are subject to nominal construction variations. It shall be the Contractor's responsibility to verify such dimensions and details in the field and make the necessary approved adjustments prior to construction or ordering of materials. Such variations shall not be cause for additional compensation for a change in the scope of work. However, the Contractor will be paid for the quantity actually furnished at the unit price for the work.

Reinforcement bars designated (E) shall be epoxy coated.

Up to 1/4 inch may be ground off the bridge deck and bridge approach slabs through Diamond Grinding.

Prior to pouring the new concrete deck, all heavy or loose rust, loose mill scale, and other loose or potentially detrimental foreign material shall be removed from the surfaces in contact with concrete. Tightly adhered paint may remain unless otherwise noted. Removal shall be accomplished by methods that will not damage the steel and the cost will be included in the pay item covering removal of the existing concrete.

Existing structural steel that will be in contact with new structural steel shall be cleaned and painted prior to erection as required by the Special Provision "Cleaning and Painting Contact Surface Areas of Existing Steel Structures".

Existing reinforcement bars extending into the removal area shall be cleaned, straightened and incorporated into the new construction. Any reinforcement bars that are damaged during concrete removal shall be replaced with approved bar splicer or anchorage system. Cost included with Concrete Removal.

Joint openings shall be adjusted according to Article 520.04 of the Std. Specs. when the deck is poured at an ambient temperature other than 50°F.

Expansion joints shall be fabricated and installed according to the manufacturer's recommendations and as approved by the Engineer.

Expansion joints shall be fabricated to conform to the existing cross slopes of the bridge.

Protective Coat shall be applied from end to end of approaches to entire deck surface and along the vertical faces of the parapets.

Slope wall shall be reinforced with welded-wire fabric, 6 in. x 6 in. - W4.0 x W4.0, weighing 58 pounds per 100 sq. ft.

Synthetic fibers shall be included in the bridge deck concrete overlay specified. See Special Provisions.

INDEX OF SHEETS

- 1 General Plan and Elevation (S.N. 057-0152)
- 2 General Plan and Elevation (S.N. 057-0153)
- 3 General Data (S.N. 057-0152 and S.N. 057-0153)
- 4 Existing and Proposed Typical Cross Sections (S.N. 057-0152)
- 5 Stage Construction Details (S.N. 057-0152)
- 6 Existing and Proposed Typical Cross Sections (S.N. 057-0153)
- 7 Stage Construction Details (S.N. 057-0153)
- 8 Wearing Surface Plan (S.N. 057-0152 and S.N. 057-0153)
- 9 Floor Drain and Patching Details (S.N. 057-0152)
- 10 Floor Drain and Patching Details (S.N. 057-0153)
- 11 Parapet Repair Plan (S.N. 057-0152 and S.N. 057-0153)
- 12 Superstructure Repair Plan - Concrete Removal Details (S.N. 057-0152)
- 13 Superstructure Repair Plan - Deck Reinforcement Details (S.N. 057-0152)
- 14 Superstructure Repair Plan - Concrete Removal Details (S.N. 057-0153)
- 15 Superstructure Repair Plan - Deck Reinforcement Details (S.N. 057-0153)
- 16 Floor Drain Details (S.N. 057-0152 and S.N. 057-0153)
- 17 Preformed Joint Strip Seal Details (S.N. 057-0152 and S.N. 057-0153)
- 18 Diaphragm Replacement and Beam End Repair Locations (S.N. 057-0152 and S.N. 057-0153)
- 19 Diaphragm Replacement and Beam End Repair Details (S.N. 057-0152 and S.N. 057-0153)
- 20 North Abutment Repairs (S.N. 057-0152)
- 21 South Abutment Repairs (S.N. 057-0152)
- 22 North Abutment Repairs (S.N. 057-0153)
- 23 South Abutment Repairs (S.N. 057-0153)
- 24 Shallow Concrete Repair Plan (S.N. 057-0152)
- 25 Shallow Concrete Repair Plan (S.N. 057-0153)
- 26 Bar Splicer Assembly and Mechanical Bar Splicer Details (S.N. 057-0152 and S.N. 057-0153)

MODEL: General Notes  
FILE NAME: P:\Effingham\3454 - PTB 189 IDOT D5 V-V\Work Order #6\Cadd\Sheet\152 & 153\0570D64\_0152\_0153\_Combined.dgn  
12/8/2021 8:44:12 AM



CIVIL DESIGN, INC.  
WBE / DBE  
EFFINGHAM, IL  
LICENSE #184.003222

USER NAME =	DESIGNED - KAS	REVISED -
	CHECKED - TJZ	REVISED -
PLOT SCALE =	DRAWN - DWS	REVISED -
PLOT DATE =	CHECKED - KAS	REVISED -

**STATE OF ILLINOIS  
DEPARTMENT OF TRANSPORTATION**

**GENERAL DATA  
S.N. 057-0152 (SB) & S.N. 057-0153 (NB)**

SHEET 3 OF 26 SHEETS

F.A.I. RTE.	SECTION	COUNTY	TOTAL SHEETS	SHEET NO.
55	(57-1,57-2)BDS	MCLEAN	88	23
			CONTRACT NO. 70D64	
			ILLINOIS FED. AID PROJECT	



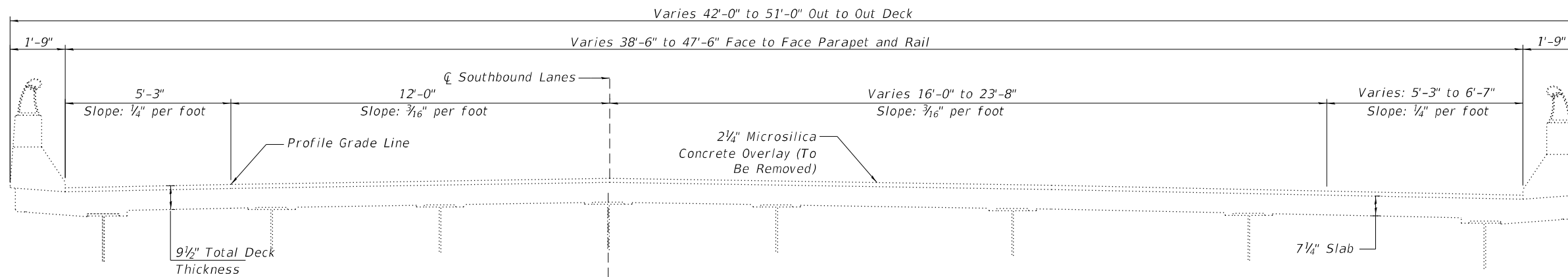

**EXISTING CROSS SECTION**  
(Looking South)

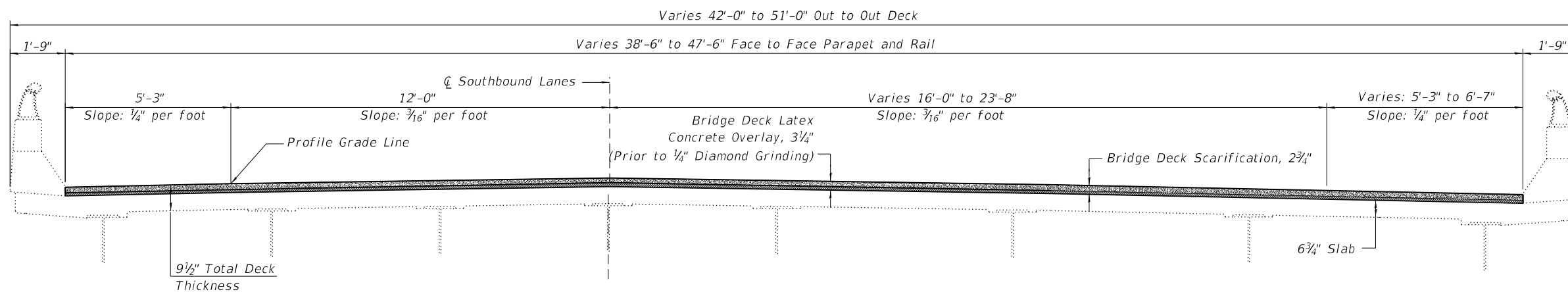

**PROPOSED CROSS SECTION**  
(Looking South)

MODEL: Cross Sections  
FILE NAME: P:\Effingham\3454 - PTB\_189 IDOT D5 V-V\Work\_Order\_#6\Cadd\Sheet\152 & 153\152\152\_0152\_0153\_Combined.dgn  
11/29/2021 12:12:37 PM



CIVIL DESIGN, INC.  
WBE / DBE  
EFFINGHAM, IL  
LICENSE # 184.003222

USER NAME =	DESIGNED - KAS	REVISED -
	CHECKED - TJZ	REVISED -
PLOT SCALE =	DRAWN - DWS	REVISED -
PLOT DATE =	CHECKED - KAS	REVISED -

STATE OF ILLINOIS  
DEPARTMENT OF TRANSPORTATION

EXISTING AND PROPOSED TYPICAL CROSS SECTIONS  
S.N. 057-0152 (SB)

SHEET 4 OF 26 SHEETS

F.A.I. RTE.	SECTION	COUNTY	TOTAL SHEETS	SHEET NO.
55	(57-1,57-2)BDS	MCLEAN	88	24
CONTRACT NO. 70D64				

ILLINOIS FED. AID PROJECT

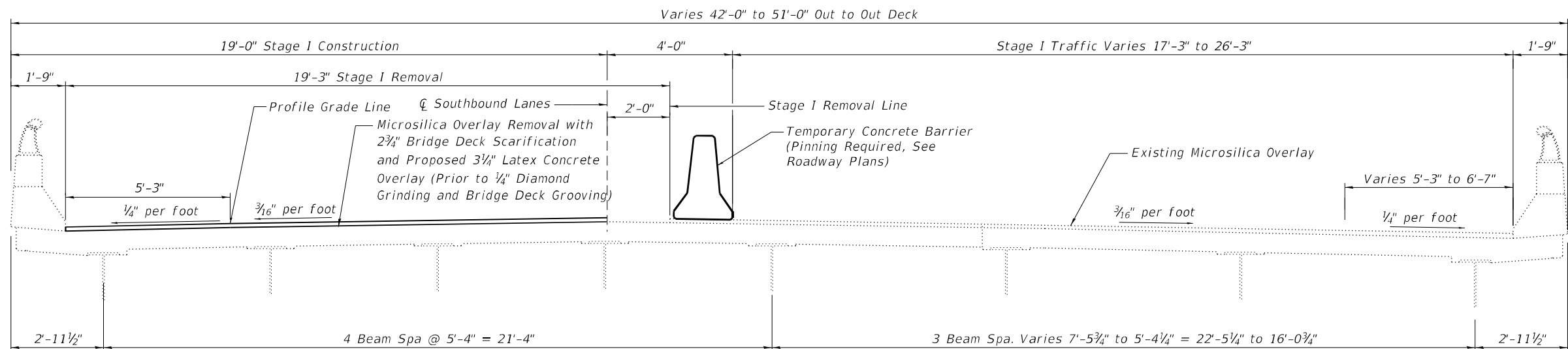

**STAGE I CONSTRUCTION DETAILS**  
(Looking South)

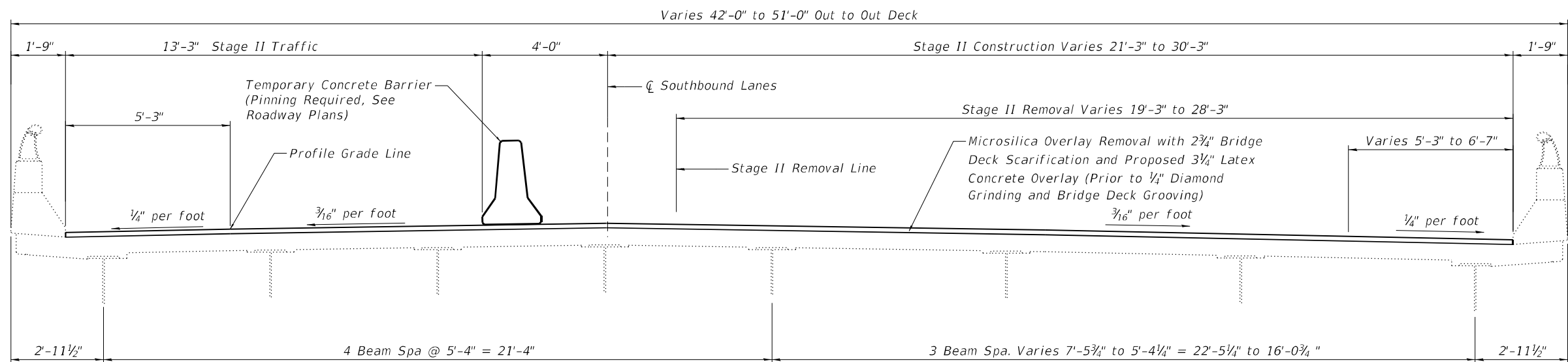

**STAGE II CONSTRUCTION DETAILS**  
(Looking South)

MODEL: Stage Const1  
FILE NAME: P:\Effingham\3454 - PTB 189 IDOT D5 V-V\Work Order #6\Cadd\Sheet\152 & 153\0570D64\_0152\_0153\_Combined.dgn  
11/29/2021 12:13:29 PM



USER NAME =	DESIGNED - KAS	REVISED -
	CHECKED - TJZ	REVISED -
PLOT SCALE =	DRAWN - DWS	REVISED -
PLOT DATE =	CHECKED - KAS	REVISED -

**STATE OF ILLINOIS  
DEPARTMENT OF TRANSPORTATION**

**STAGE CONSTRUCTION DETAILS  
S.N. 057-0152 (SB)**

SHEET 5 OF 26 SHEETS

F.A.I. RTE.	SECTION	COUNTY	TOTAL SHEETS	SHEET NO.
55	(57-1,57-2)BDS	MCLEAN	88	25
			CONTRACT NO. 70D64	

ILLINOIS FED. AID PROJECT

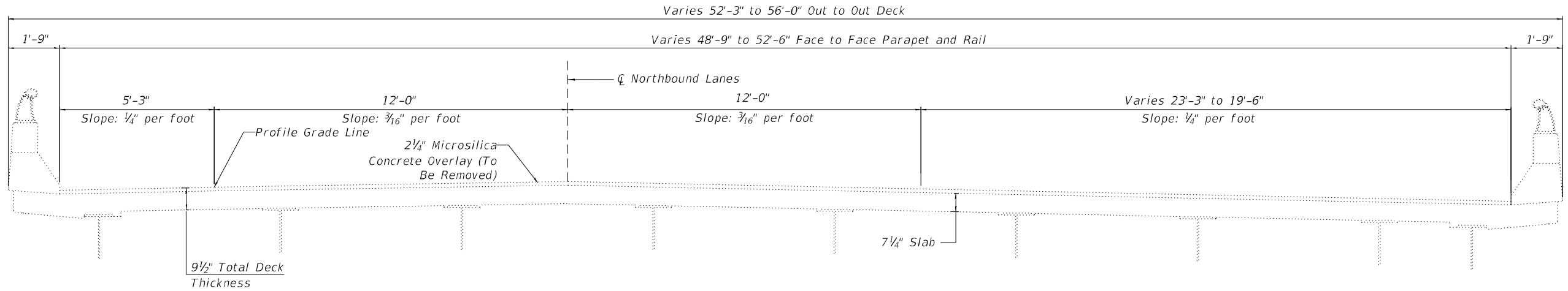

**EXISTING CROSS SECTION**  
(Looking North)

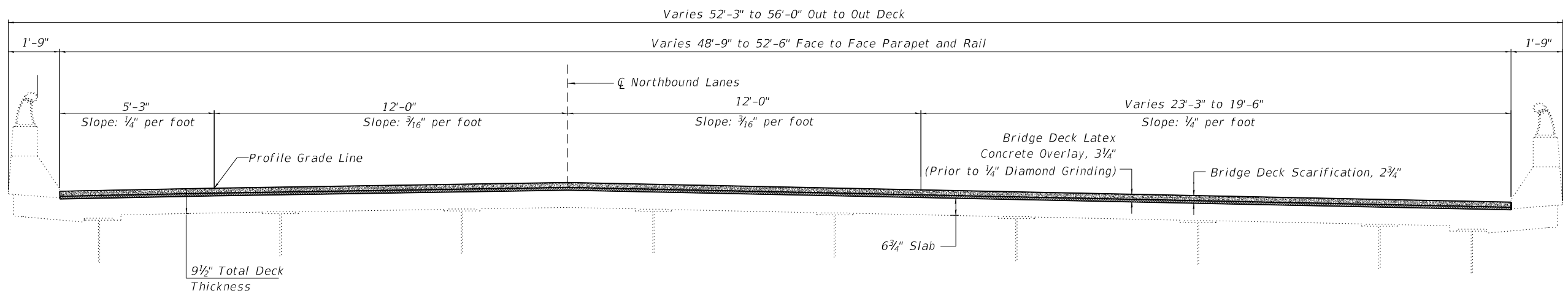

**PROPOSED CROSS SECTION**  
(Looking North)

MODEL: Cross Sect. 1  
FILE NAME: P:\Effingham\3454 - PTB 189 IDOT D5 V-V\Work Order #6\Cadd\Sheet\152 & 153\152\152\_0153\_Combined.dgn



CIVIL DESIGN, INC.  
WBE / DBE  
EFFINGHAM, IL  
LICENSE # 184.003222

USER NAME =	DESIGNED - KAS	REVISED -
	CHECKED - TJZ	REVISED -
PLOT SCALE =	DRAWN - DWS	REVISED -
PLOT DATE =	CHECKED - KAS	REVISED -

STATE OF ILLINOIS  
DEPARTMENT OF TRANSPORTATION

EXISTING AND PROPOSED TYPICAL CROSS SECTIONS  
S.N. 057-0153 (NB)

SHEET 6 OF 26 SHEETS

F.A.I. RTE.	SECTION	COUNTY	TOTAL SHEETS	SHEET NO.
55	(57-1,57-2)BDS	MCLEAN	88	26
			CONTRACT NO. 70D64	
		ILLINOIS FED. AID PROJECT		

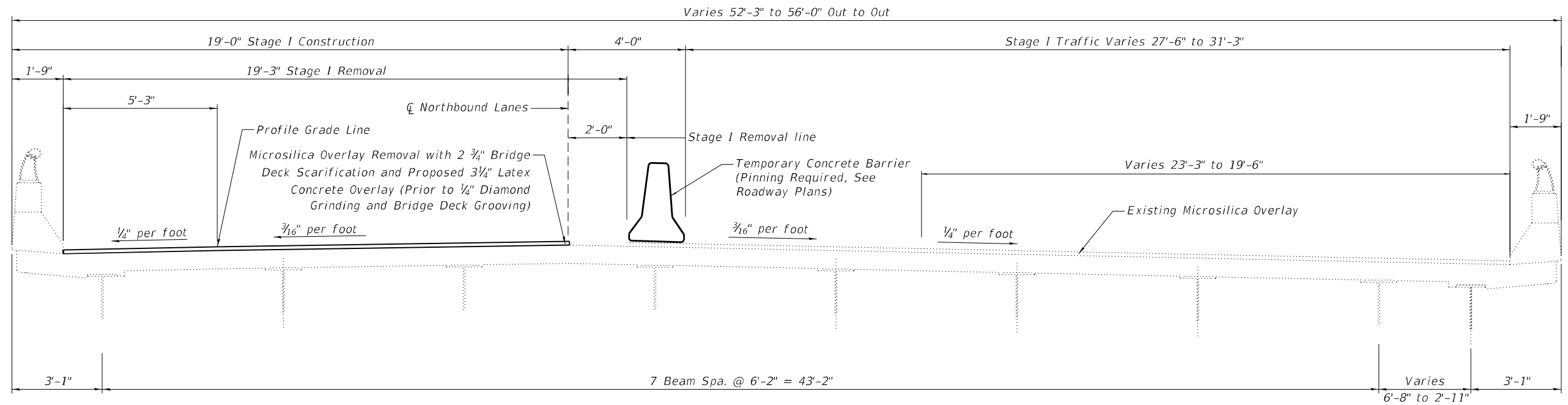

**STAGE I CONSTRUCTION DETAILS**

(Looking North)

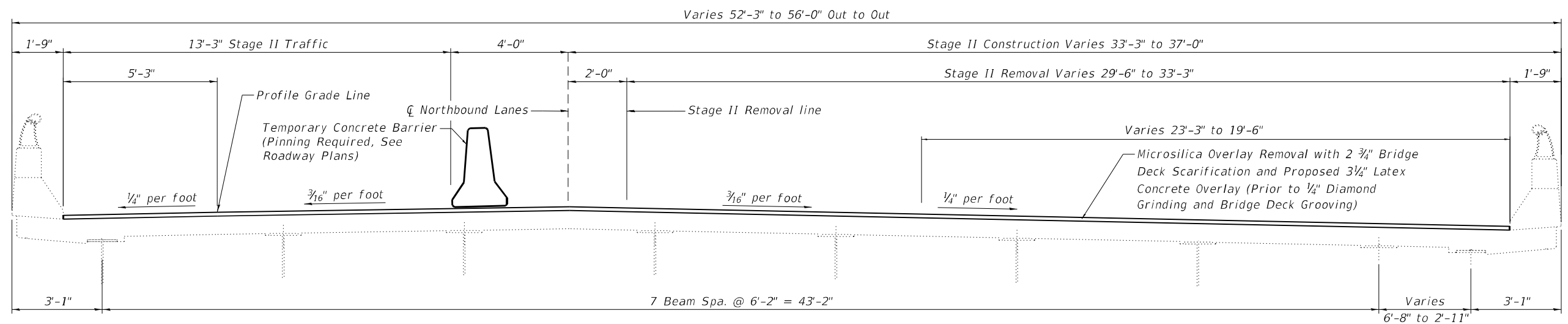

**STAGE II CONSTRUCTION DETAILS**

(Looking North)

MODEL: Stage Const. 2  
 FILE NAME: P:\Effingham\3454 - PTB 189 IDOT D5 VAVWork Order #6\Cadd\Sheet\152 & 153\0570D64\_0152\_0153\_Combined.dgn



CIVIL DESIGN, INC.  
 WBE / DBE  
 EFFINGHAM, IL  
 LICENSE # 184.003222

USER NAME =	DESIGNED - KAS	REVISED -
	CHECKED - TJZ	REVISED -
PLOT SCALE =	DRAWN - DWS	REVISED -
PLOT DATE =	CHECKED - KAS	REVISED -

STATE OF ILLINOIS  
 DEPARTMENT OF TRANSPORTATION

STAGE CONSTRUCTION DETAILS  
 S.N. 057-0153 (NB)

SHEET 7 OF 26 SHEETS

F.A.I. RTE.	SECTION	COUNTY	TOTAL SHEETS	SHEET NO.
55	(57-1,57-2)BDS	MCLEAN	88	27
			CONTRACT NO. 70D64	
ILLINOIS FED. AID PROJECT				

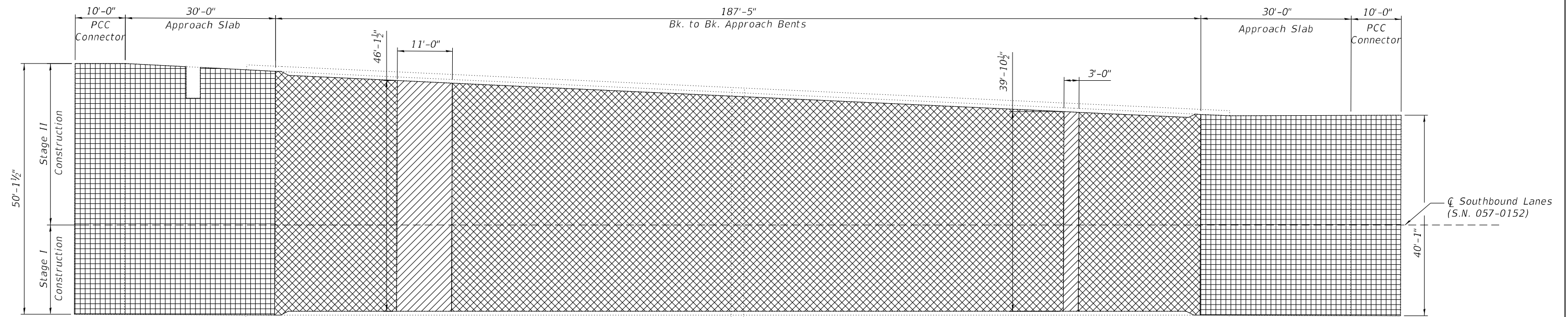

PLAN

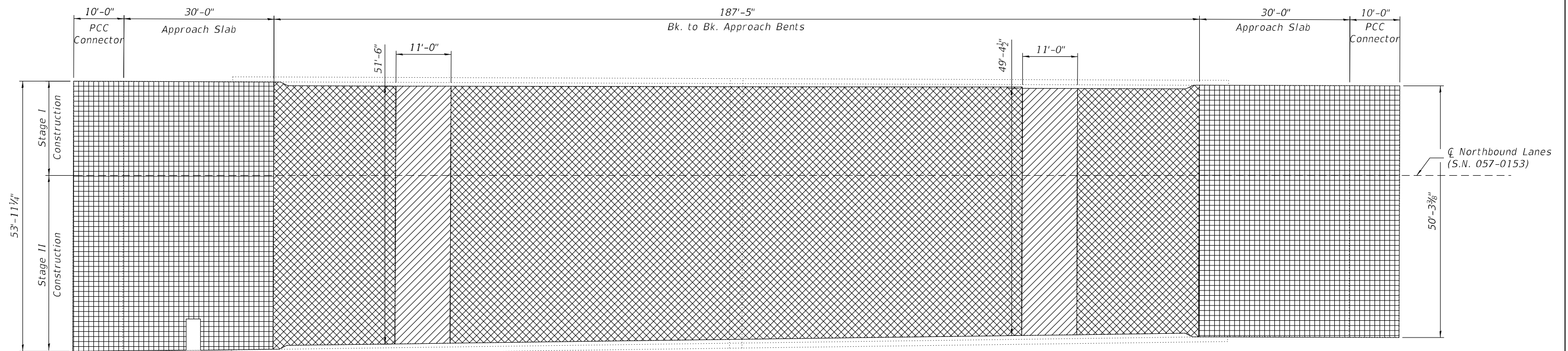
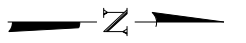

PLAN

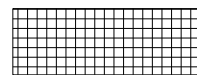

Bridge Deck Scarification, 2", Bridge Deck Latex Concrete Overlay, 2 1/4",  
Diamond Grinding, 1/4" and Bridge Deck Grooving (Longitudinal)

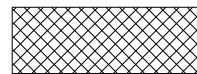

Bridge Deck Scarification, 2 3/4", Bridge Latex Concrete Overlay, 3",  
Diamond Grinding, 1/4" and Bridge Deck Grooving (Longitudinal)



Diamond Grinding, 1/4" and Bridge Deck Grooving (Longitudinal)  
(Areas of full depth removal at Deck Ends)

**BILL OF MATERIAL**  
(Deck & Approach)

Note:  
Care must be taken not to damage the existing  
shoulder drains in the approaches.

Structure	Item	Unit	Total
057-0152	Bridge Deck Latex Concrete Overlay, 3"	Sq. Yd.	829
	Bridge Deck Latex Concrete Overlay, 2 1/4"	Sq. Yd.	397
	Bridge Deck Scarification, 2 3/4"	Sq. Yd.	829
	Bridge Deck Scarification, 2"	Sq. Yd.	397
	Bridge Deck Grooving (Longitudinal)	Sq. Yd.	933
	Diamond Grinding (Bridge Section)	Sq. Yd.	1194

Structure	Item	Unit	Total
057-0153	Bridge Deck Latex Concrete Overlay, 3"	Sq. Yd.	925
	Bridge Deck Latex Concrete Overlay, 2 1/4"	Sq. Yd.	463
	Bridge Deck Scarification, 2 3/4"	Sq. Yd.	925
	Bridge Deck Scarification, 2"	Sq. Yd.	463
	Bridge Deck Grooving (Longitudinal)	Sq. Yd.	1144
	Diamond Grinding (Bridge Section)	Sq. Yd.	1413

MODEL: Wearing Surface  
FILE NAME: P:\Effingham\3454 - PTB\_189.IDOT.D5.V\Work Order #6\Cadd\Sheet\152 & 153\0570D64\_0152\_0153\_Combined.dgn

**CIVIL DESIGN, INC.**  
WBE | DBE  
EFFINGHAM, IL  
LICENSE # 184.003222

USER NAME =	DESIGNED - KAS	REVISED -
PLOT SCALE =	CHECKED - TJZ	REVISED -
PLOT DATE =	DRAWN - DWS	REVISED -
	CHECKED - KAS	REVISED -

STATE OF ILLINOIS  
DEPARTMENT OF TRANSPORTATION

WEARING SURFACE PLAN  
S.N. 057-0152 (SB) & S.N. 057-0153 (NB)

SHEET 8 OF 26 SHEETS

F.A.I. RTE.	SECTION	COUNTY	TOTAL SHEETS	SHEET NO.
55	(57-1.57-2)BDS	MCLEAN	88	28
			CONTRACT NO. 70D64	
ILLINOIS FED. AID PROJECT				

MODEL: Floor Drain and Patching  
 FILE NAME: P:\Effingham\3454 - PTB\_189\_IDOT D5 V-V\Work Order #6\Cadd\Sheet\152 & 153\152\057-0152\_0152\_Combined.dgn

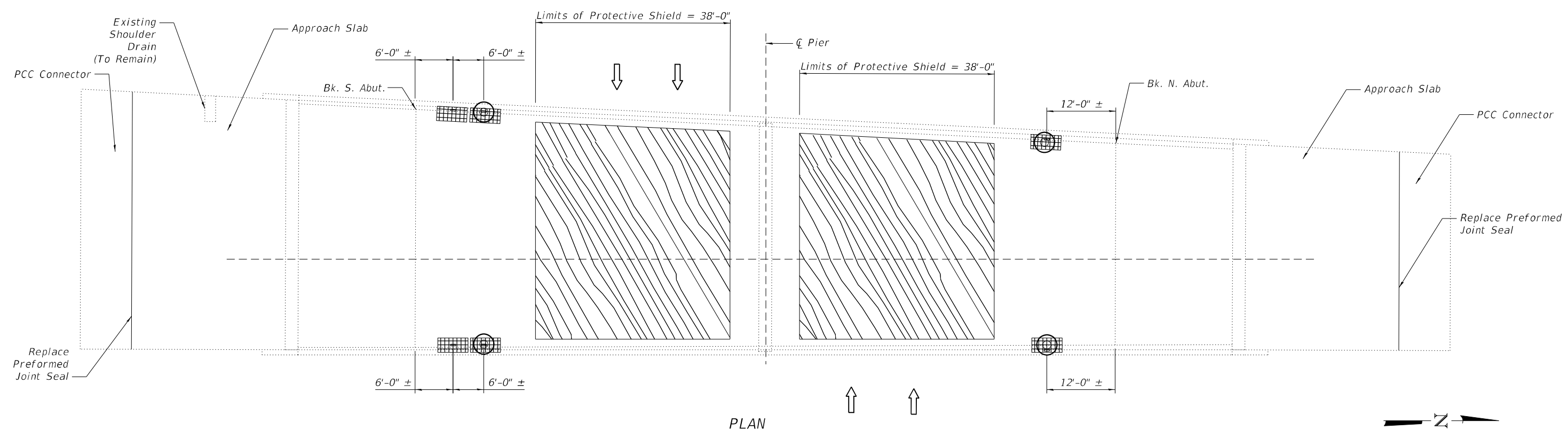

PLAN

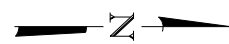

**NOTES:**

Patch sizes shown represent conditions at the time the plans were completed. An Estimated 2% of the Deck Area has been included should additional Deck Slab Repair (Full Depth, Type I) be required after Bridge Deck Scarification.

The actual sizes and locations of patching shall be determined by the Resident Engineer after removal of the wearing surface, before patching operations begin. The Engineer shall show the actual locations of the deck repairs on As-Built plans.

The existing slab drains and extensions shall be removed. Cost included with Deck Slab Repair (Full Depth, Type I).

Care must be taken not to damage the existing shoulder drains in the approaches.

Extreme care must be used when removing concrete near the top flange of the beams. The Contractor is responsible for any damage to the beams.

See Sheet 16 of 26 for Floor Drain Details.

**LEGEND**

- Proposed floor drain location
- Deck Slab Repair (Full Depth, Type I) at all Drain Locations. All repair areas are 2'-0" x 1'-1", unless otherwise noted.
- Protective Shield

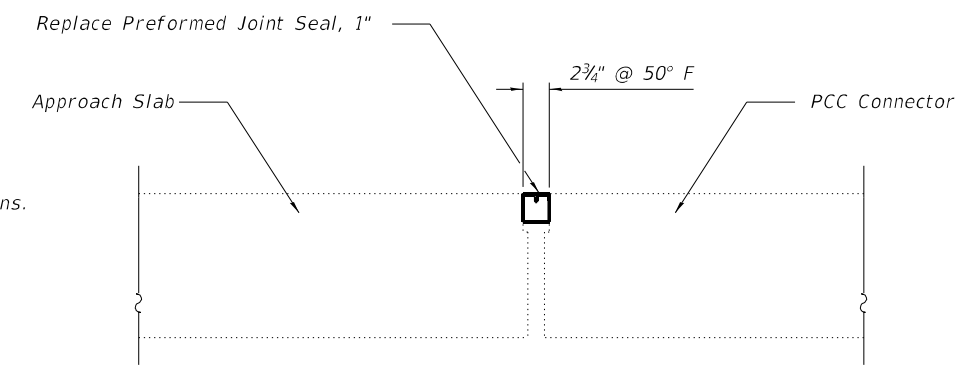

**PREFORMED JOINT REPLACEMENT DETAIL**  
 S.N. 057-0152 North & South Approach

**BILL OF MATERIAL**

Structure	Item	Unit	Total
057-0152	Deck Slab Repair (Full Depth, Type I)	Sq. Yd.	20
057-0152	Protective Shield	Sq. Yd.	343
057-0152	Preformed Joint Seal, 1"	Foot	90

**CIVIL DESIGN, INC.**  
 WBE / DBE  
 EFFINGHAM, IL  
 LICENSE # 184.003222

USER NAME =	DESIGNED - KAS	REVISED -
	CHECKED - TJZ	REVISED -
PLOT SCALE =	DRAWN - DWS	REVISED -
PLOT DATE =	CHECKED - KAS	REVISED -

**STATE OF ILLINOIS**  
**DEPARTMENT OF TRANSPORTATION**

**FLOOR DRAIN AND PATCHING DETAILS**  
**S.N. 057-0152 (SB)**

SHEET 9 OF 26 SHEETS

F.A.I. RTE.	SECTION	COUNTY	TOTAL SHEETS	SHEET NO.
55	(57-1.57-2)BDS	MCLEAN	88	29
			CONTRACT NO. 70D64	
ILLINOIS FED. AID PROJECT				

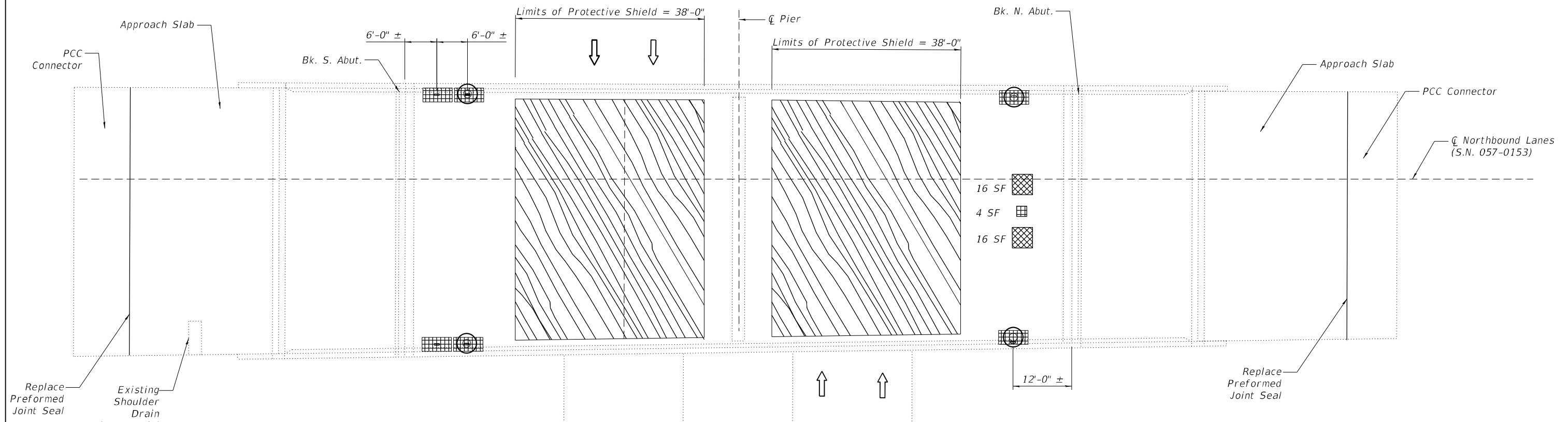
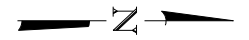

**PLAN**

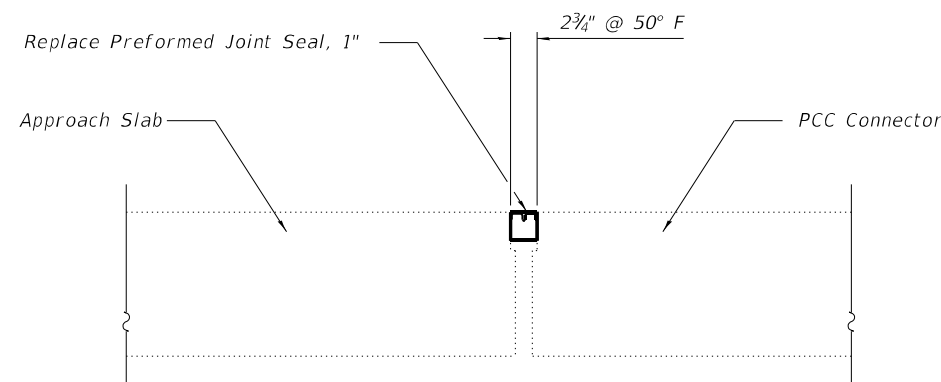

**PREFORMED JOINT REPLACEMENT DETAIL**

S.N. 057-0153 North and South Approach

**NOTES:**

- Patch sizes shown represent conditions at the time the plans were completed. An Estimated 4% of the Deck Area has been included should additional Deck Slab Repair (Full Depth, Type I) be required after Bridge Deck Scarification.
- The actual sizes and locations of patching shall be determined by the Resident Engineer after removal of the wearing surface, before patching operations begin. The Engineer shall show the actual locations of the deck repairs on As-Built plans.
- The existing drains and extensions shall be removed. Cost included with Deck Slab Repair (Full Depth, Type I).
- Care must be taken not to damage the existing shoulder drains in the approaches.
- Extreme care must be used when removing concrete near the top flange of the beams. The Contractor is responsible for any damage to the beams.
- See Sheet 17 of 26 for Floor Drain Details.

**BILL OF MATERIAL**

Structure	Item	Unit	Total
057-0153	Deck Slab Repair (Full Depth, Type I)	Sq. Yd.	42
057-0153	Deck Slab Repair (Full Depth, Type II)	Sq. Yd.	4
057-0153	Protective Shield	Sq. Yd.	405
057-0153	Preformed Joint Seal, 1"	Foot	105

**LEGEND**

- Proposed floor drain location
- Deck Slab Repair (Full Depth, Type I) at all Drain Locations. All repair areas are 2'-0" x 1'-1", unless otherwise noted.
- Deck Slab Repair (Full Depth, Type II)
- Protective Shield

MODEL: Patching Details  
FILE NAME: P:\Effingham\3454 - PTB\_189.IDOT.D5.V\Work Order #6\Cadd\Sheet\152 & 153\152\152\_0153\_Combined.dgn



USER NAME =	DESIGNED - KAS	REVISED -
	CHECKED - TJZ	REVISED -
PLOT SCALE =	DRAWN - DWS	REVISED -
PLOT DATE =	CHECKED - KAS	REVISED -

**STATE OF ILLINOIS  
DEPARTMENT OF TRANSPORTATION**

**FLOOR DRAIN AND PATCHING DETAILS  
S.N. 057-0153 (NB)**

SHEET 10 OF 26 SHEETS

F.A.I. RTE.	SECTION	COUNTY	TOTAL SHEETS	SHEET NO.
55	(57-1.57-2)BDS	MCLEAN	88	30
			CONTRACT NO. 70D64	
		ILLINOIS FED. AID PROJECT		

MODEL: Parapet Repair Plan  
 FILE NAME: P:\Effingham\3454 - PTB 189 IDOT D5 V-V\Work Order #6\Cadd\Sheet\152 & 153\152\_0152\_0153\_Combined.dgn

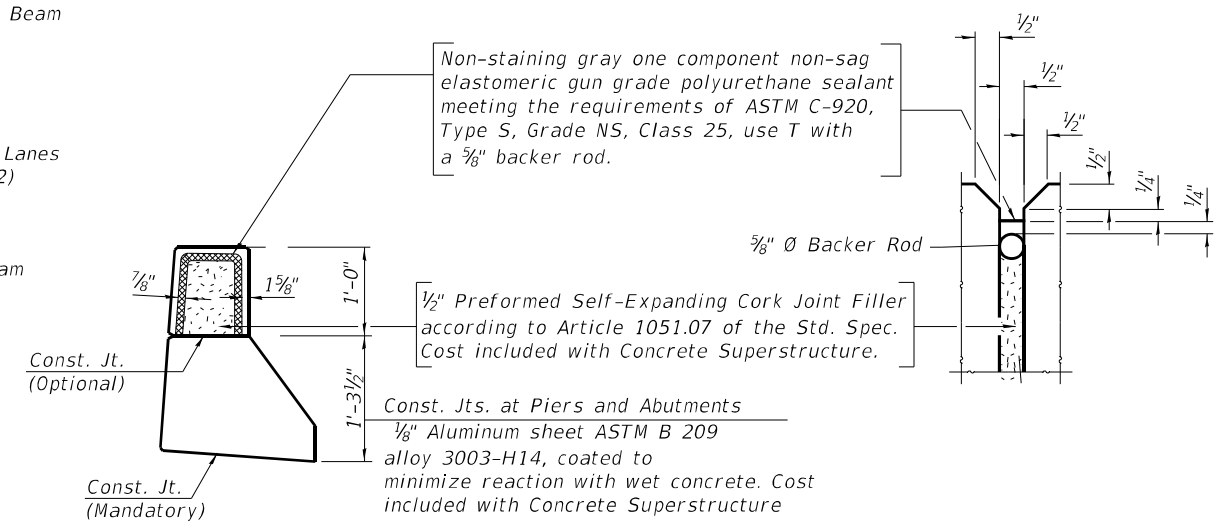
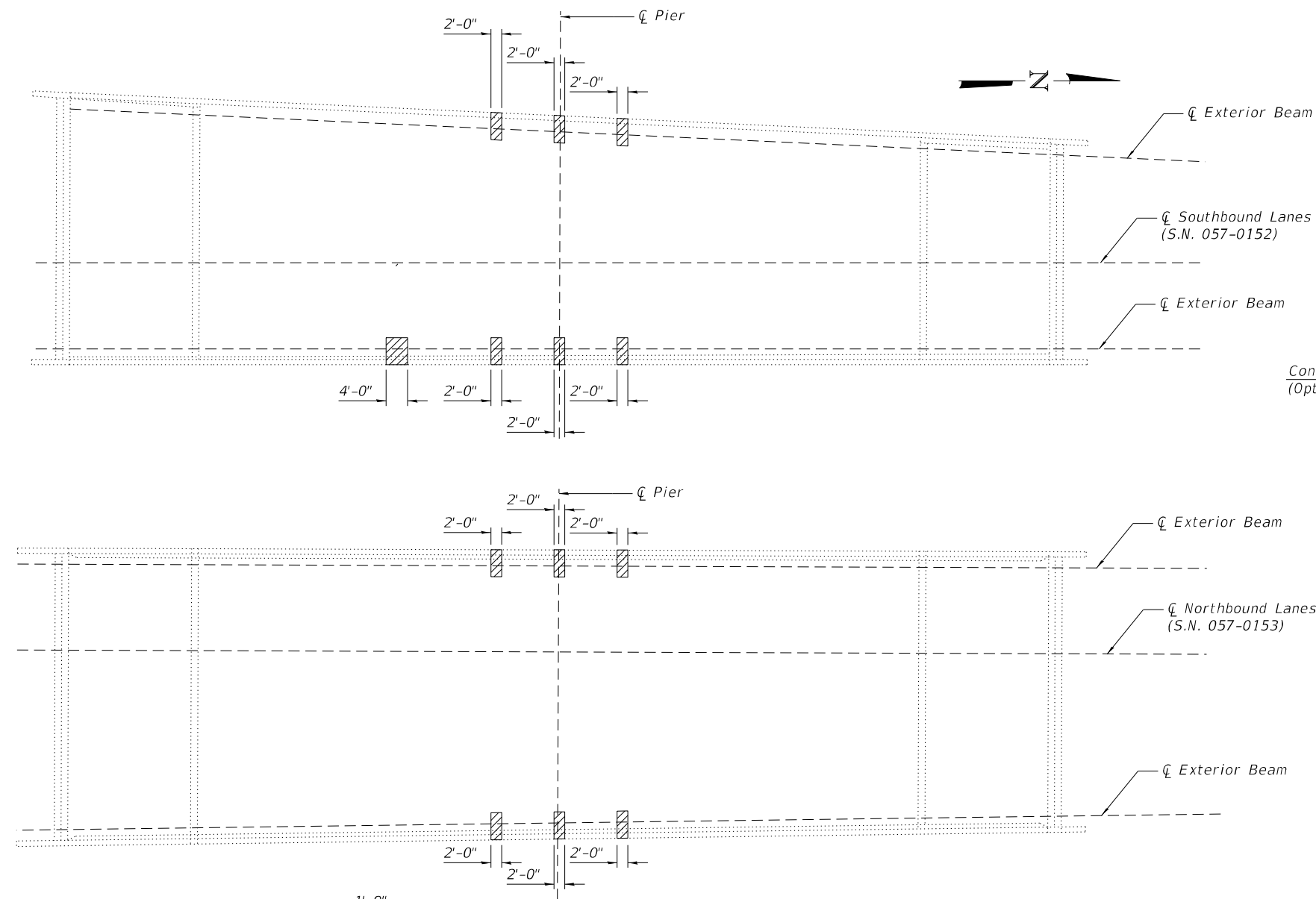

**PARAPET JOINT DETAILS**

**NOTES:**

The Rail Posts within the parapet removal and replacement limits shall be removed to allow for the repair work to be completed. Following completion of the parapet ends, the Rail Posts shall be re-attached. It is the option of the Contractor to either save and reuse the existing cast-in-place anchor system or use epoxy-grouted threaded rods. The cost of this work shall be included in Concrete Superstructure. See As-Built Plans for aluminum railing detail.

Areas of Concrete Removal and Superstructure were identified July 28, 2020. The Engineer shall determine if additional areas require removal and replacement at time of construction.

The cost of the work to replace parapet joints shall be included in Concrete Superstructure.

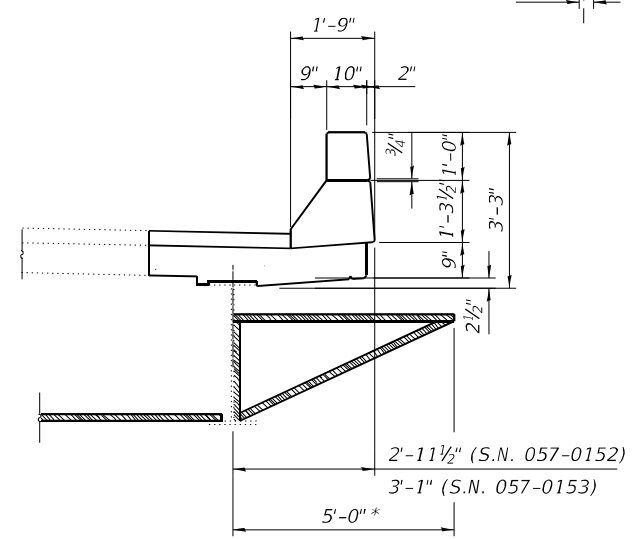

**PROTECTIVE SHIELD**

\* Shield under parapet is shown as suggestion only. Pay Limit for Protective Shield is center-to-center fascia beams.

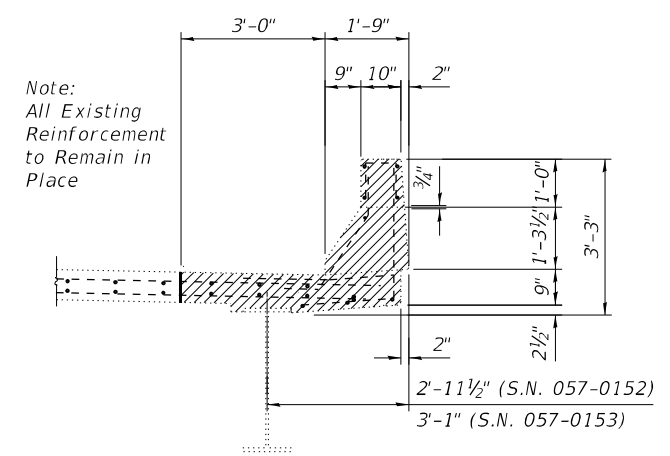

**PARAPET REMOVAL**

Note:  
All Existing Reinforcement to Remain in Place

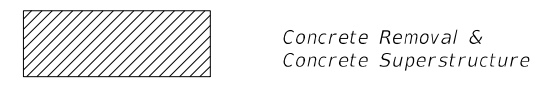

**BILL OF MATERIAL**

Structure	Item	Unit	Total
057-0152	Concrete Removal	Cu. Yd.	3.6
	Concrete Superstructure	Cu. Yd.	3.6
057-0153	Concrete Removal	Cu. Yd.	2.7
	Concrete Superstructure	Cu. Yd.	2.7



CIVIL DESIGN, INC.  
 WBE / DBE  
 EFFINGHAM, IL  
 LICENSE # 184.003222

USER NAME =	DESIGNED - KAS	REVISED -
PLOT SCALE =	CHECKED - TJZ	REVISED -
PLOT DATE =	DRAWN - DWS	REVISED -
	CHECKED - KAS	REVISED -

STATE OF ILLINOIS  
 DEPARTMENT OF TRANSPORTATION

PARAPET REPAIR PLAN  
 S.N. 057-0152 (SB) & S.N. 057-0153 (NB)

SHEET 11 OF 26 SHEETS

F.A.I. RTE.	SECTION	COUNTY	TOTAL SHEETS	SHEET NO.
55	(57-1,57-2)BDS	MCLEAN	88	31
			CONTRACT NO. 70D64	
		ILLINOIS FED. AID PROJECT		



MODEL: Concrete Removal Details  
 FILE NAME: P:\Effingham\3454 - PTB 189 IDOT D5 V-VI\Work Order #6\Cadd\Sheet\152 & 153\152\057-0152\_0152\_Combined.dgn  
 11/29/2021 12:17:19 PM

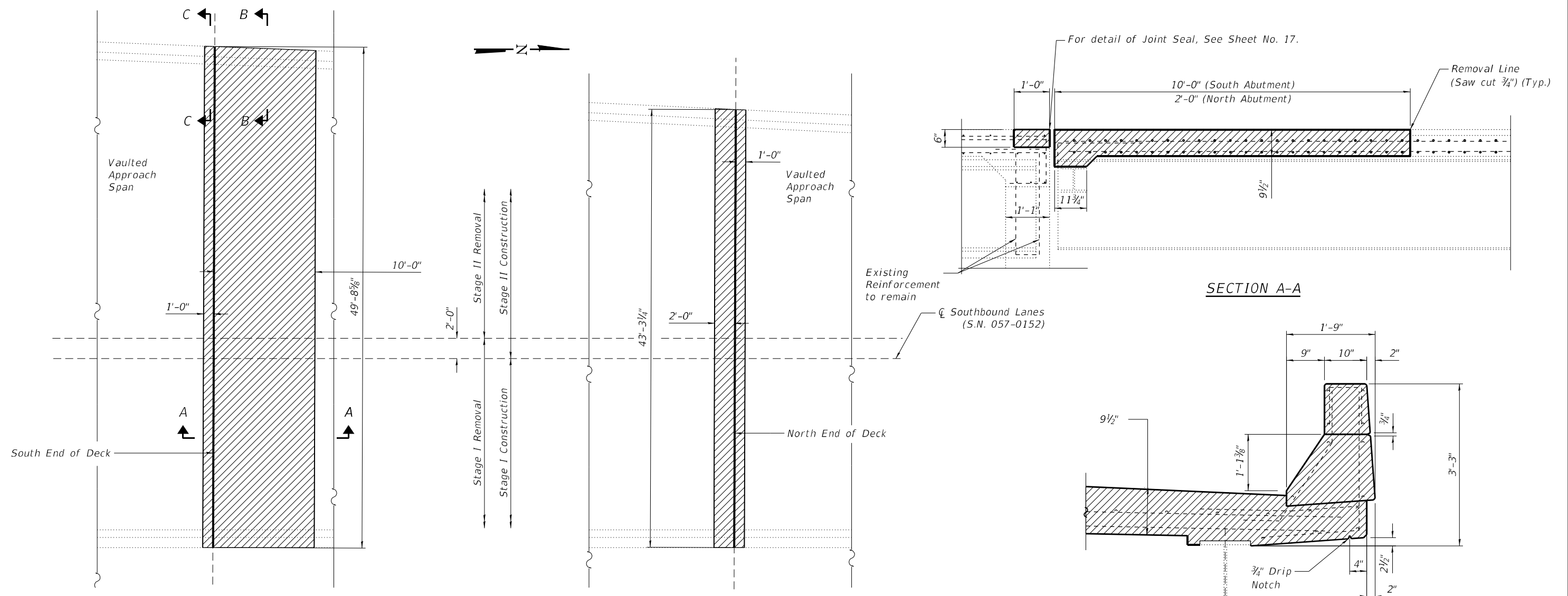

PLAN

SECTION A-A

SECTION B-B

SECTION C-C

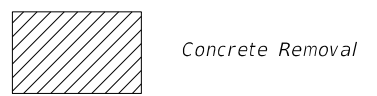

**NOTES:**

Existing reinforcement bars extending into the removal area shall be cleaned, straightened and incorporated into the New Construction. Any reinforcement bars that are damaged during Concrete Removal shall be replaced with an approved bar splicer or anchorage system. Cost included with Concrete Removal.

The existing expansion joint system shall be removed completely, as well as any foreign material that has accumulated or been placed in the joint openings. The cost for this work is included in Concrete Removal and no additional compensation will be allowed.

The handrail attached to the top of the parapets shall be unbolted to allow for the removal and placement of the parapet ends. Following completion of the parapet ends, the handrail shall be re-attached. The cost of this work shall be included in Concrete Superstructures.

All existing deck tie downs shall be removed. Cost included with Concrete Removal.

**BILL OF MATERIAL**

Structure	Item	Unit	Total
057-0152	Concrete Removal	Cu. Yd.	24.1



CIVIL DESIGN, INC.  
 WBE / DBE  
 EFFINGHAM, IL  
 LICENSE # 184.003222

USER NAME =	DESIGNED - KAS	REVISED -
PLOT SCALE =	CHECKED - TJZ	REVISED -
PLOT DATE =	DRAWN - DWS	REVISED -
	CHECKED - KAS	REVISED -

STATE OF ILLINOIS  
 DEPARTMENT OF TRANSPORTATION

SUPERSTRUCTURE PLAN - CONCRETE REMOVAL DETAILS  
 S.N. 057-0152 (SB)

SHEET 12 OF 26 SHEETS

F.A.I. RTE. 55	SECTION (57-1.57-2)BDS	COUNTY MCLEAN	TOTAL SHEETS 88	SHEET NO. 32
CONTRACT NO. 70D64				ILLINOIS FED. AID PROJECT

MODEL: Deck Reinforcement  
 FILE NAME: P:\Effingham\3454 - PTB 189 IDOT D5 VAVWork Order #6\Cadd\Sheet\152 - 153\152\_0152\_0153\_Combined.dgn  
 12/6/2021 7:21:58 AM

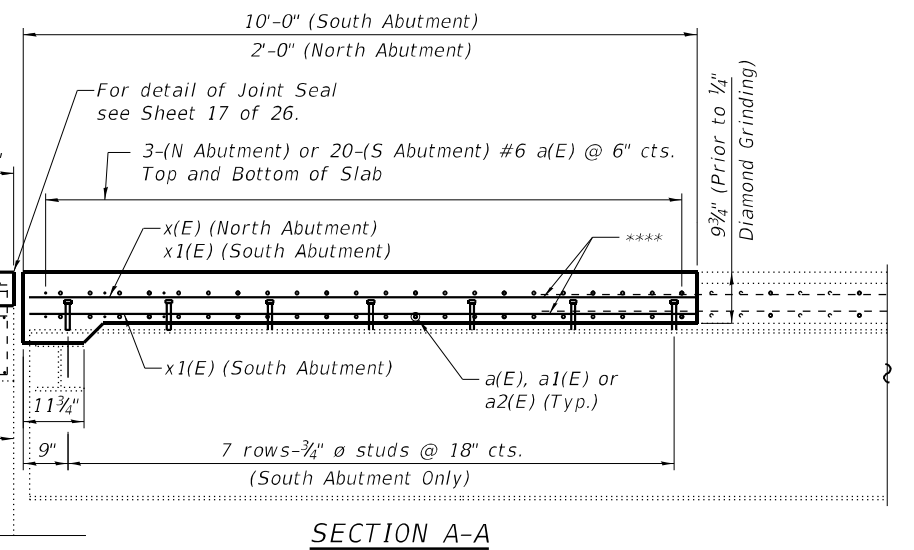
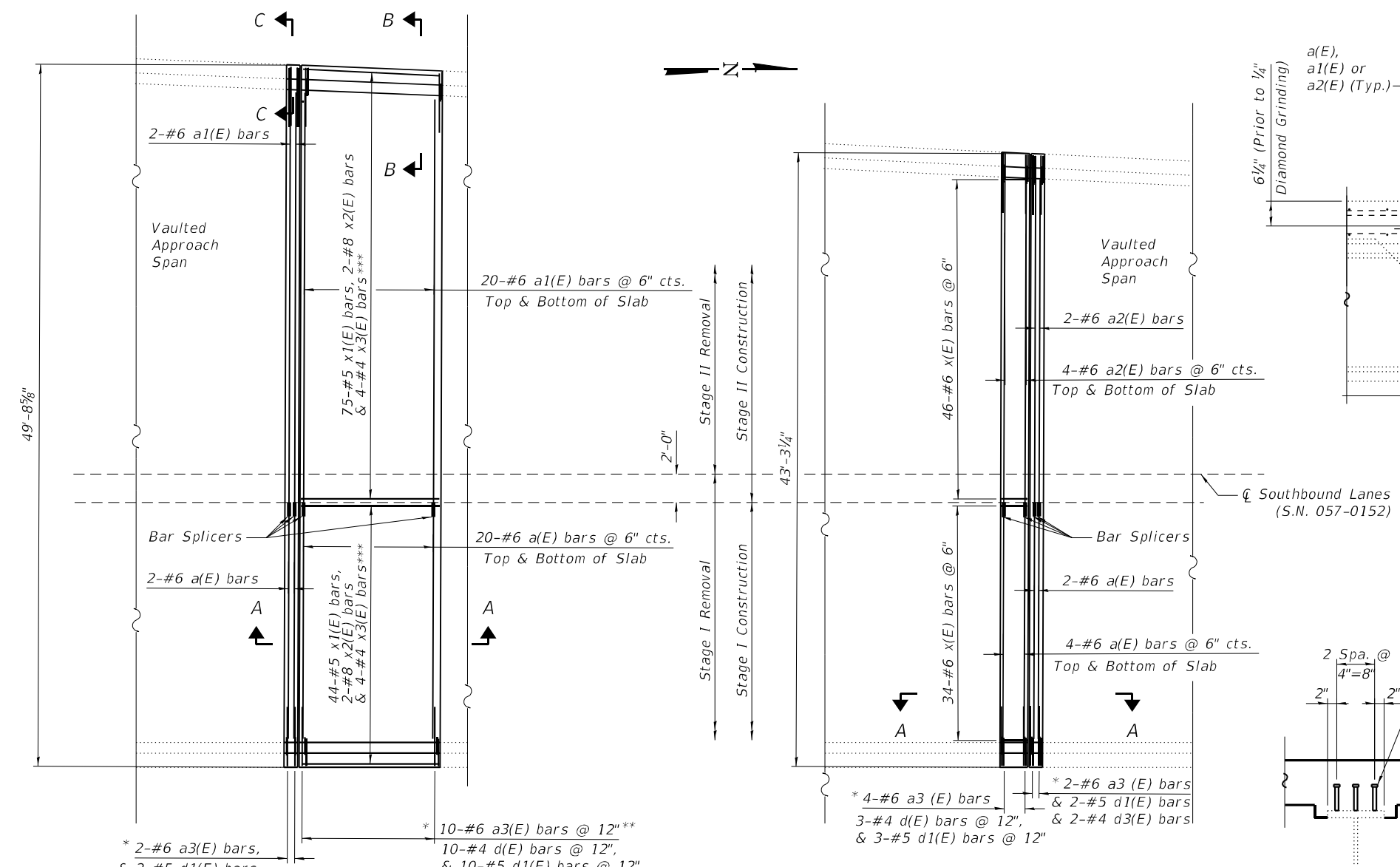

**NOTES:**

Reinforcement bars designated (E) shall be epoxy coated.

The parapet shall be removed on the deck side and approach side as shown.

The aluminum railing post shall be temporarily removed and re-erected in the areas of parapet removal. Cost included with Concrete Superstructure. Any portion of railing that is damaged during construction shall be replaced at the Contractor's expense.

Two d2(E) bars shall be set in proposed parapet under each rail post.

\*\*\*\* At South Abutment cut existing longitudinal bars in slab and parapet with 3'-6" (#4 & #5 bars) or 5'-11" (#8 bars) projection and lap with x(E), x1(E), or x2(E) bars.

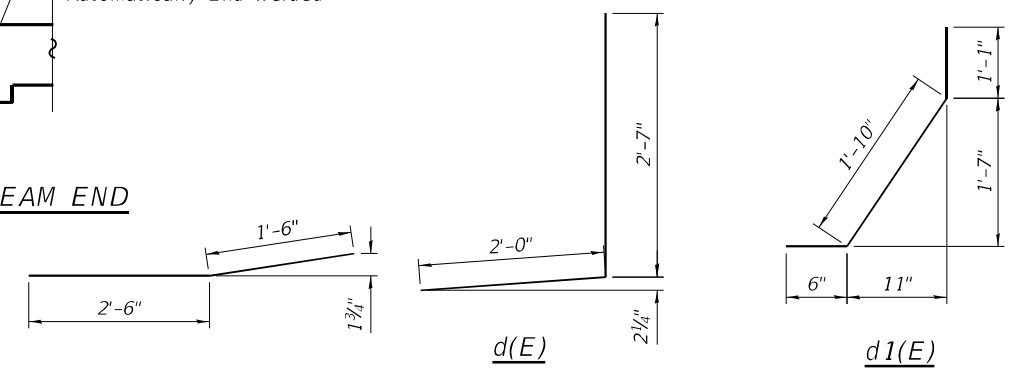
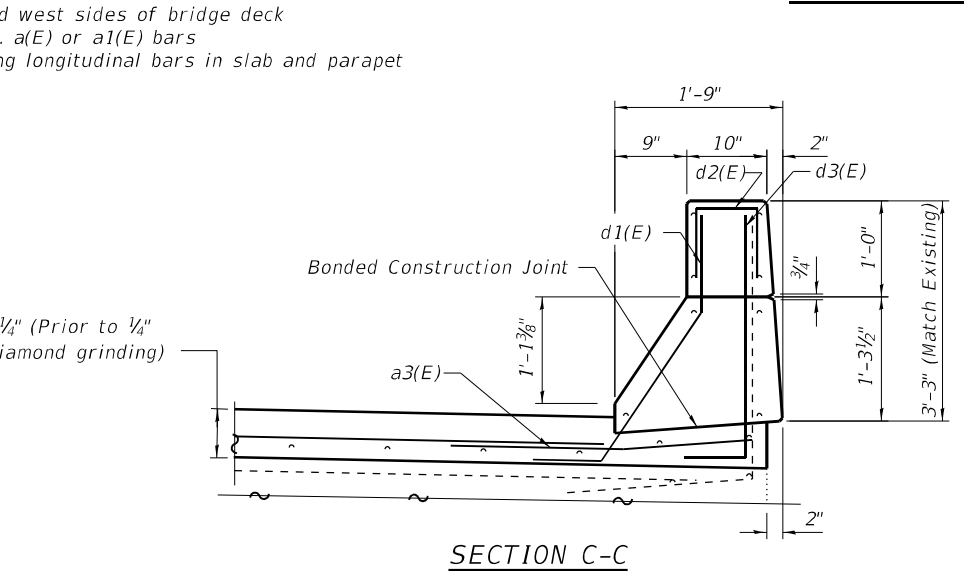
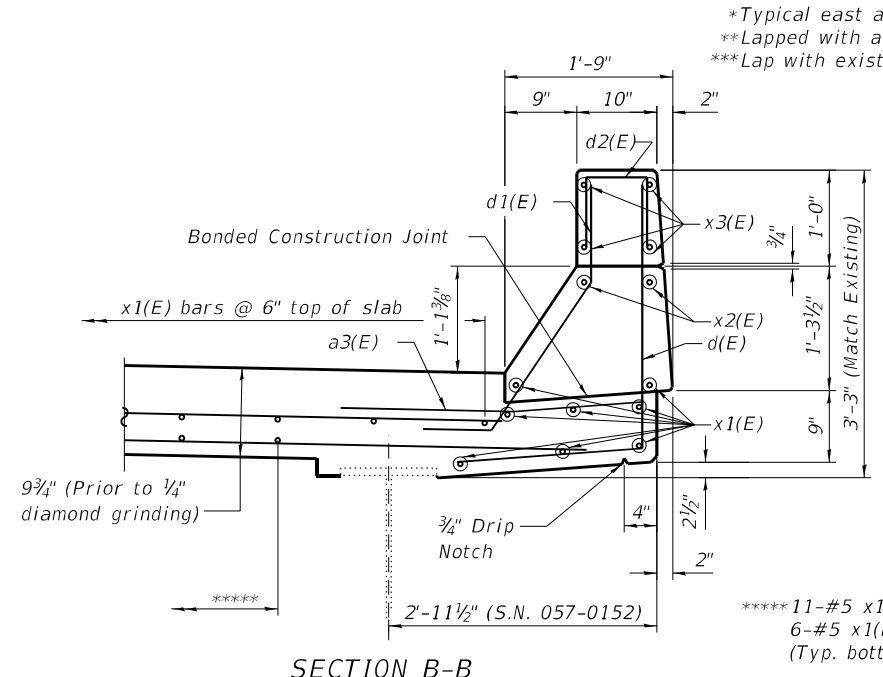
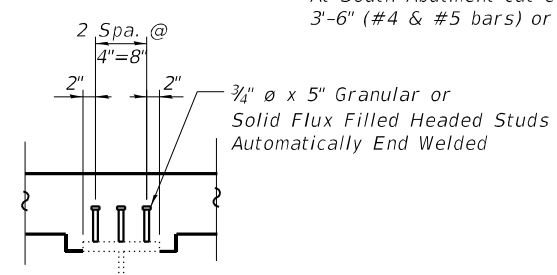

Bar	No.	Size	Length	Shape
a(E)	52	#6	19'-3"	—
a1(E)	42	#6	27'-0"	—
a2(E)	10	#6	20'-6"	—
a3(E)	34	#6	4'-0"	—
d(E)	26	#4	4'-7"	—
d1(E)	34	#5	3'-5"	—
d2(E)	12	#4	2'-1"	—
d3(E)	8	#4	3'-7"	—
x(E)	80	#6	2'-3"	—
x1(E)	119	#5	9'-10"	—
x2(E)	4	#8	9'-10"	—
x3(E)	8	#4	9'-10"	—
Reinforcement Bars, Epoxy Coated		Pound	5600	
Concrete Superstructure		Cu. Yd.	24.1	

MODEL: Concrete Removal Details-2  
 FILE NAME: P:\Effingham\3454 - PTB 189 IDOT D5 V-VI\Work Order #6\Cadd\Sheet\152 & 153\0570D64\_0152\_0153\_Combined.dgn

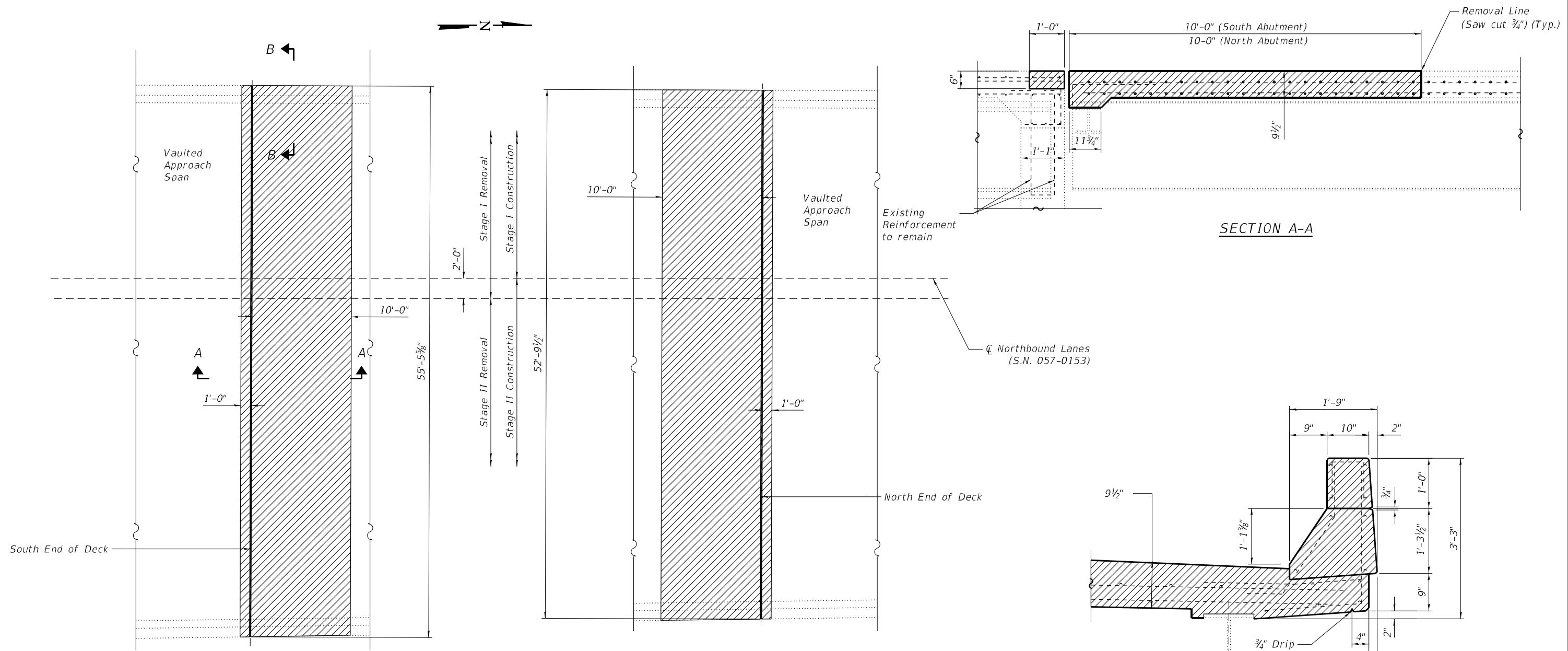

**NOTES:**

Existing reinforcement bars extending into the removal area shall be cleaned, straightened and incorporated into the New Construction. Any reinforcement bars that are damaged during Concrete Removal shall be replaced with an approved bar splicer or anchorage system. Cost included with Concrete Removal.

The existing expansion joint system shall be removed completely, as well as any foreign material that has accumulated or been placed in the joint openings. The cost for this work is included in Concrete Removal and no additional compensation will be allowed.

The handrail attached to the top of the parapets shall be unbolted to allow for the removal and placement of the parapet ends. Following completion of the parapet ends, the handrail shall be re-attached. The cost of this work shall be included in Concrete Superstructures.

All existing deck tie downs shall be removed. Cost included with Concrete Removal.

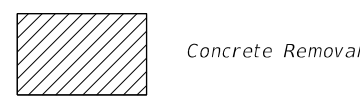

**PLAN**

**SECTION B-B**

**BILL OF MATERIAL**

Structure	Item	Unit	Total
057-0153	Concrete Removal	Cu. Yd.	41.6



CIVIL DESIGN, INC.  
 WBE / DBE  
 EFFINGHAM, IL  
 LICENSE #184.003222

USER NAME =	DESIGNED - KAS	REVISED -
	CHECKED - TJZ	REVISED -
PLOT SCALE =	DRAWN - DWS	REVISED -
PLOT DATE =	CHECKED - KAS	REVISED -

STATE OF ILLINOIS  
 DEPARTMENT OF TRANSPORTATION

SUPERSTRUCTURE PLAN - CONCRETE REMOVAL DETAILS  
 S.N. 057-0153 (NB)

SHEET 14 OF 26 SHEETS

F.A.I. RTE.	SECTION	COUNTY	TOTAL SHEETS	SHEET NO.
55	(57-1,57-2)BDS	MCLEAN	88	34
CONTRACT NO. 70D64			ILLINOIS FED. AID PROJECT	

MODEL: Deck Reinforcement-2  
 FILE NAME: P:\Effingham\3454 - PTB 189 IDOT D5 V-VWork Order #6\Cadd\Sheet\152 & 153\0570D64\_0152\_0153\_Combined.dgn  
 12/6/2021 7:22:42 AM

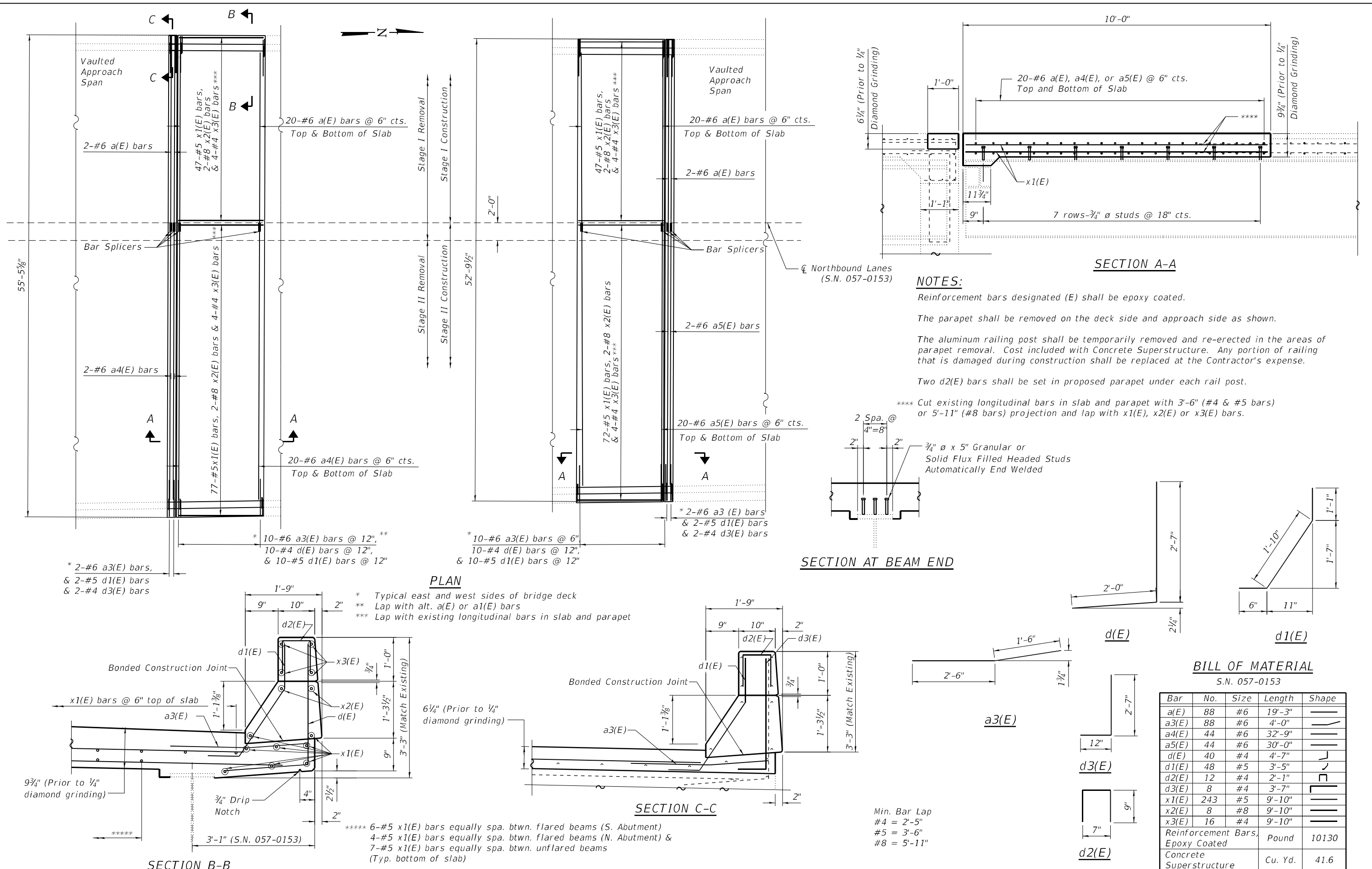

**SECTION A-A**

10'-0"

20-#6 a(E), a4(E), or a5(E) @ 6" cts. Top and Bottom of Slab

1'-0"

20-#6 a(E) bars

7 rows-3/4"  $\phi$  studs @ 18" cts.

11 3/4"

9"

6 1/4" (Prior to 1/4" Diamond Grinding)

9 3/4" (Prior to 1/4" Diamond Grinding)

Northbound Lanes (S.N. 057-0153)

**NOTES:**

Reinforcement bars designated (E) shall be epoxy coated.

The parapet shall be removed on the deck side and approach side as shown.

The aluminum railing post shall be temporarily removed and re-erected in the areas of parapet removal. Cost included with Concrete Superstructure. Any portion of railing that is damaged during construction shall be replaced at the Contractor's expense.

Two d2(E) bars shall be set in proposed parapet under each rail post.

\*\*\*\* Cut existing longitudinal bars in slab and parapet with 3'-6" (#4 & #5 bars) or 5'-11" (#8 bars) projection and lap with x1(E), x2(E) or x3(E) bars.

2 Spa. @ 4"=8"

3/4"  $\phi$  x 5" Granular or Solid Flux Filled Headed Studs Automatically End Welded

**BILL OF MATERIAL**  
S.N. 057-0153

Bar	No.	Size	Length	Shape
a(E)	88	#6	19'-3"	—
a3(E)	88	#6	4'-0"	—
a4(E)	44	#6	32'-9"	—
a5(E)	44	#6	30'-0"	—
d(E)	40	#4	4'-7"	└
d1(E)	48	#5	3'-5"	└
d2(E)	12	#4	2'-1"	└
d3(E)	8	#4	3'-7"	└
x1(E)	243	#5	9'-10"	—
x2(E)	8	#8	9'-10"	—
x3(E)	16	#4	9'-10"	—
Reinforcement Bars, Epoxy Coated			Pound	10130
Concrete Superstructure			Cu. Yd.	41.6

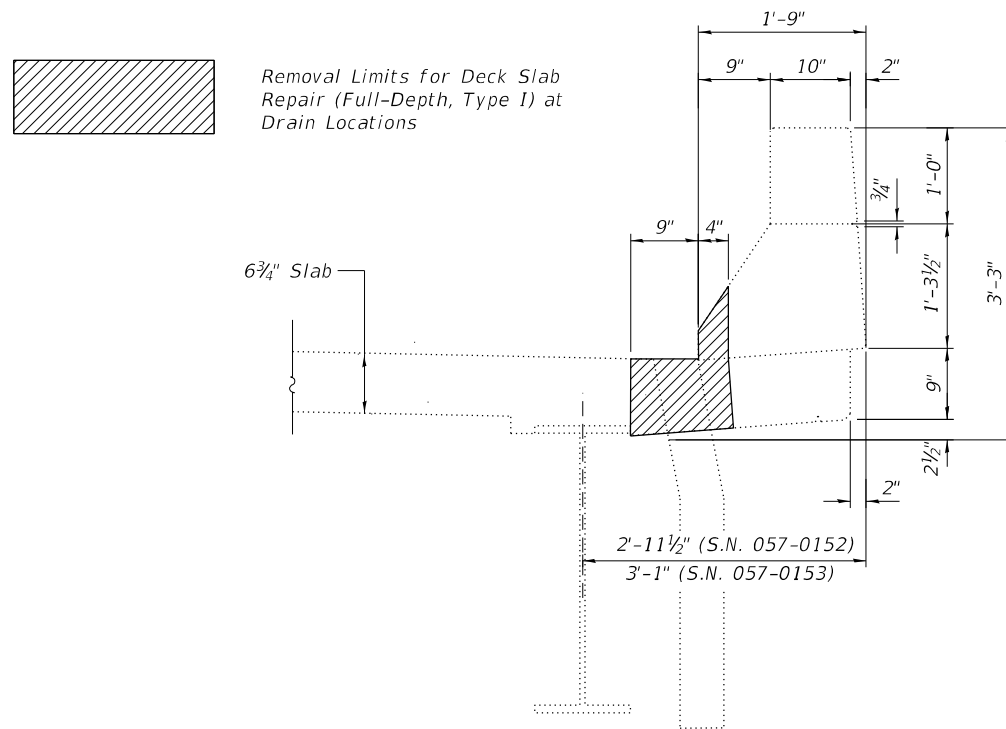

TYPICAL REMOVAL LIMITS

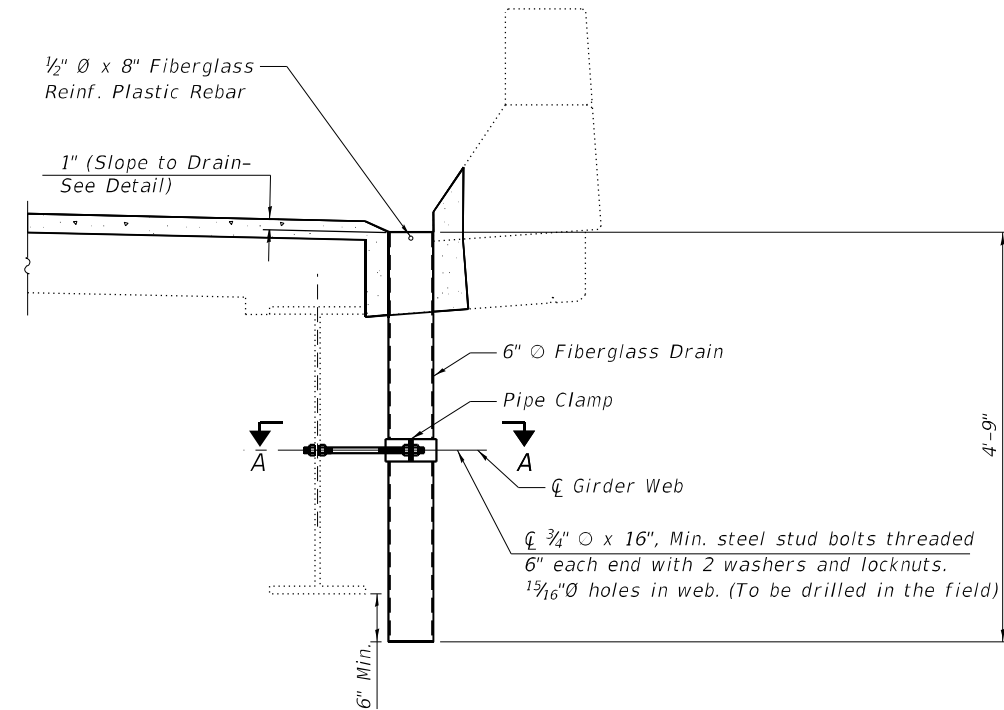

NEW FLOOR DRAIN INSTALLATION

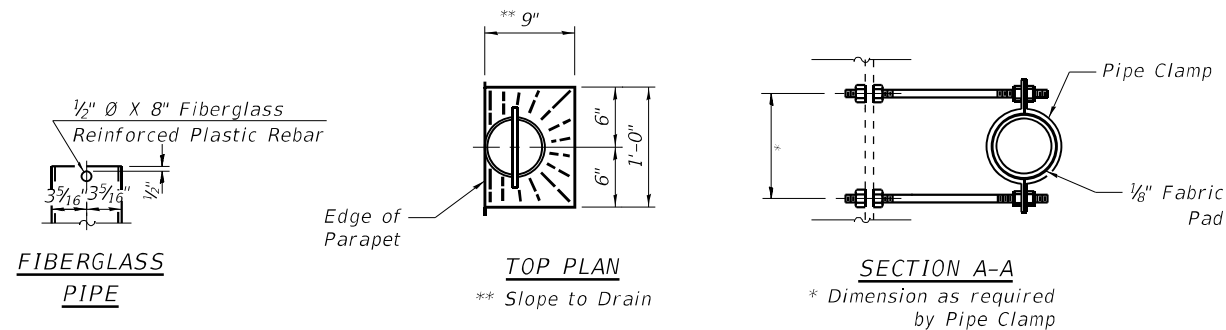

Notes:

- All dimensions shall be field verified by the Contractor prior to ordering of materials.
- Fiberglass shall conform to ASTM 02996, with short-time rupture strength hoop tensile stress of 30,000 psi minimum.
- The exterior surfaces of the floor drains shall be painted according to Article 506 with the finish coat as specified.
- The exterior surfaces of the drains shall be cleaned according to the Society of Protective Coating Spec. SSPC-SPI prior to painting.
- The clamping device shall be galvanized according to AASHTO M 232. Cost of clamping device included with Floor Drains.

BILL OF MATERIAL

Structure	Item	Unit	Total
057-0152	Floor Drains	Each	4
057-0153	Floor Drains	Each	4

Cost of removal of existing drains and extensions is included in Deck Slab Repair (Full Depth, Type I)

MODEL: Floor Drain  
FILE NAME: P:\Effingham\3454 - PTB 189 IDOT D5 V-V\Work Order #6\Cadd\Sheet\152 & 153\152\152\_0152\_0153\_Combined.dgn  
11/29/2021 12:19:54 PM



CIVIL DESIGN, INC.  
WBE / DBE  
EFFINGHAM, IL  
LICENSE # 184.003222

USER NAME =	DESIGNED - KAS	REVISED -
PLOT SCALE =	CHECKED - TJZ	REVISED -
PLOT DATE =	DRAWN - DWS	REVISED -
	CHECKED - KAS	REVISED -

STATE OF ILLINOIS  
DEPARTMENT OF TRANSPORTATION

FLOOR DRAIN DETAILS  
S.N. 057-0152 (SB) & S.N. 057-0153 (NB)

SHEET 16 OF 26 SHEETS

F.A.I. RTE.	SECTION	COUNTY	TOTAL SHEETS	SHEET NO.
55	(57-1,57-2)BDS	MCLEAN	88	36
			CONTRACT NO. 70D64	
		ILLINOIS FED. AID PROJECT		

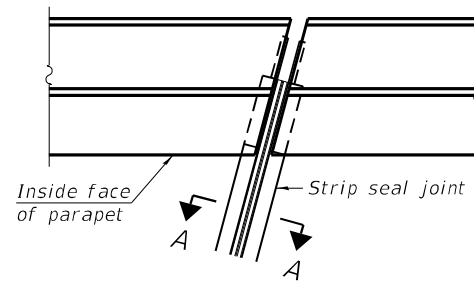

PLAN AT PARAPET

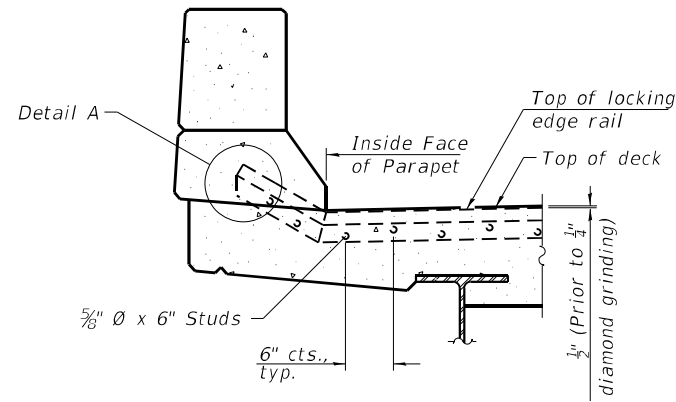

ELEVATION AT PARAPET

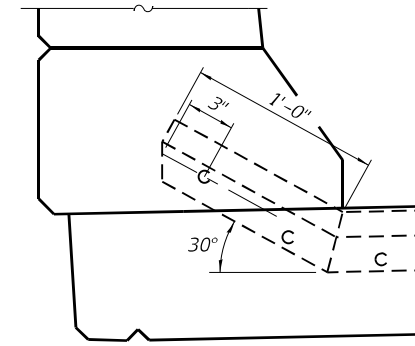

DETAIL A

Notes:

The strip seal shall be made continuous and shall have a minimum thickness of 1/4". The configuration of the strip seal shall match the configuration of the locking edge rails. Open or "webbed" strip seal gland configurations are not permitted. The gland shall be sized for a maximum rated movement of 4 inches.

The locking edge rails depicted are configured for typical applications and are conceptual only. The actual configuration of the locking edge rails and matching strip seal may vary from manufacturer to manufacturer provided they fit the application and meet the minimum anchorage shown. Flanged edge rails, however, will not be allowed. Locking edge rails may exceed the 4 1/2" maximum depth provided the anchorage system is revised according to the manufacturer's recommendation.

The manufacturer's recommended installation methods shall be followed.

All steel components shall be galvanized after fabrication according to Article 520.03 of the Standard Specifications.

The Maximum space between locking edge rail segments shall be 3/16" and sealed with a suitable sealant; however, any rail joint within 10' measured perpendicular to the face of the curb or parapet shall be welded as shown in the locking edge rail splice detail.

The concrete opening below the strip seal will vary based on the locking edge rail chosen by the Contractor. Deck and parapet lengths shown elsewhere in the plans are dimensioned to the concrete opening, not the joint opening, and are based on the rolled locking edge rail. If the Contractor elects to use a different locking edge rail, dimensional adjustments may be required. One exception to this would be the strip seal joint at the end of the precast bridge approach slab. For these cases the pavement connector length shall be adjusted, not the length of the bridge approach slab.

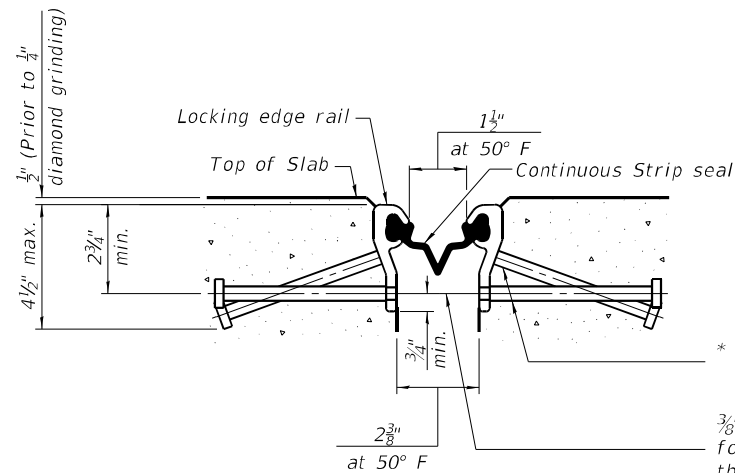

SHOWING ROLLED RAIL JOINT

\* 5/8"  $\phi$  x 6" studs @ 6" cts. (alternate angled/bent studs with horizontal studs)

3/8"  $\phi$  threaded rods in 1/16"  $\phi$  holes at  $\pm 4'-0"$  cts. for holding the proper joint opening based on the temperature during the deck pour. Place to miss studs. All rods shall be burned, or sawed off flush with the plates after concrete is set.

SECTION A-A

\* Granular or solid flux filled headed studs conforming to Article 1006.32 of the Std. Specs., automatically end welded.

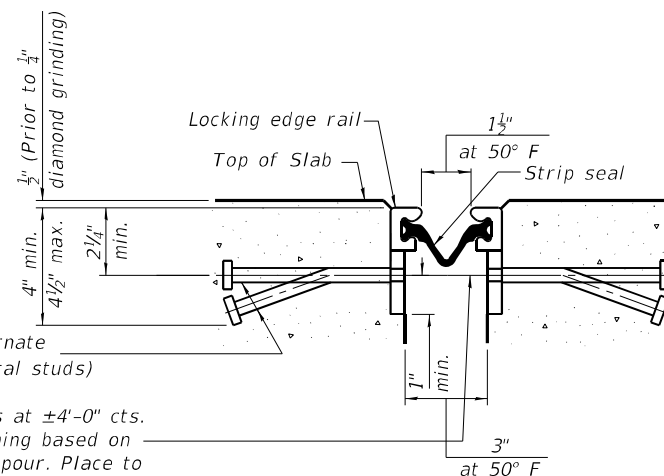

SHOWING WELDED RAIL JOINT

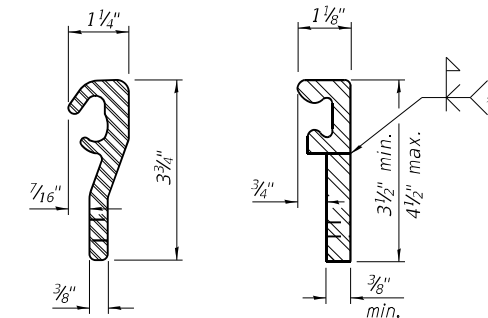

LOCKING EDGE RAILS

\*\* Back gouge not required if complete joint penetration is verified by mock-up.

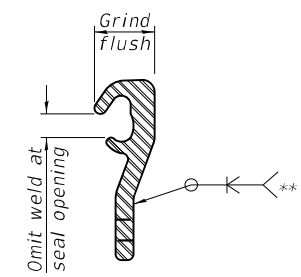

LOCKING EDGE RAIL SPLICE

The inside of the locking edge rail groove shall be free of weld residue. Rolled rail shown, welded rail similar.

BILL OF MATERIAL

Structure	Item	Unit	Total
057-0152	Preformed Joint Strip Seal	Foot	91
057-0153	Preformed Joint Strip Seal	Foot	106

MODEL: Joint Strip Seal Details  
FILE NAME: P:\Effingham\3454 - PTB\_189\_IDOT D5 V-V\Work Order #6\Cadd\Sheet\152 & 153\0570D64\_0152\_0153\_Combined.dgn

USER NAME =	DESIGNED - KAS	REVISED -
PLOT SCALE =	CHECKED - TJZ	REVISED -
PLOT DATE =	DRAWN - DWS	REVISED -
	CHECKED - KAS	REVISED -

STATE OF ILLINOIS  
DEPARTMENT OF TRANSPORTATION

PREFORMED JOINT STRIP SEAL DETAILS  
S.N. 057-0152 (SB) & S.N. 057-0153 (NB)

F.A.I. RTE.	SECTION	COUNTY	TOTAL SHEETS	SHEET NO.
55	(57-1.57-2)BDS	MCLEAN	88	37
			CONTRACT NO. 70D64	
		ILLINOIS FED. AID PROJECT		

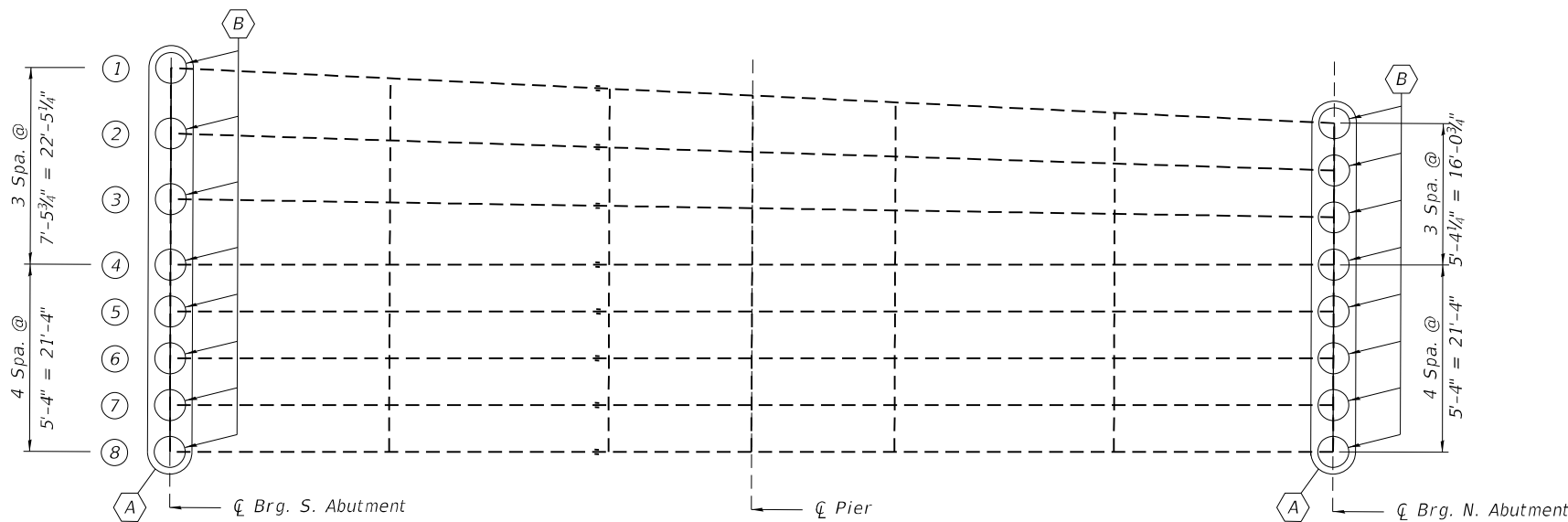

FRAMING PLAN - S.N. 057-0152 (SB)

- A Diaphragm Replacement (Furnishing and Erecting Structural Steel and Structural Steel Removal)
- B Beam End Repair (Structural Steel Repair)

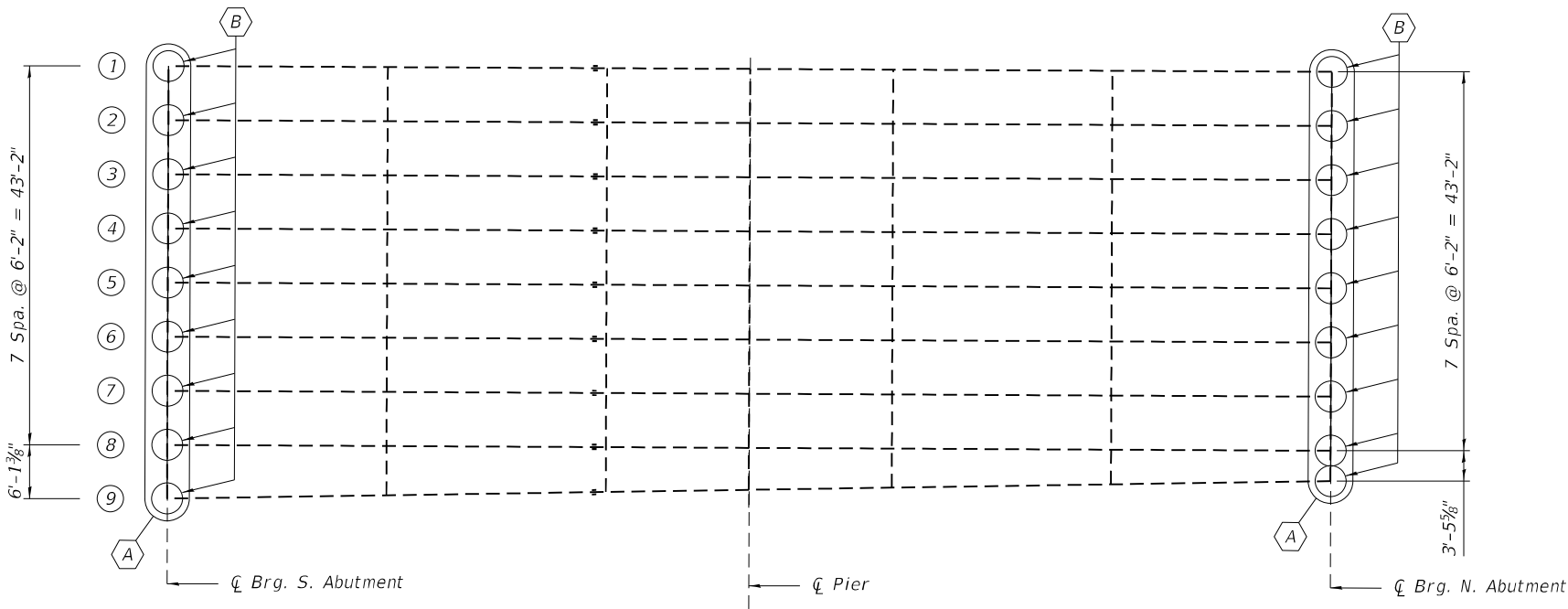

FRAMING PLAN - S.N. 057-0153 (NB)

- A Diaphragm Replacement (Furnishing and Erecting Structural Steel and Structural Steel Removal)
- B Beam End Repair (Structural Steel Repair)

**NOTES:**

All structural steel shall conform to AASHTO Classification M-270 GR. 36, unless otherwise noted.

Fasteners shall be high strength bolts. Bolts 3/4"Ø, open holes 1 3/16"Ø, unless otherwise noted.

Diaphragm connection holes shall be 1 3/16"Ø for 3/4"Ø bolts. Two hardened washers shall be required at diaphragm connections.

Plan dimensions and details relative to existing plans are subject to nominal construction variations. The Contractor shall field verify existing dimensions and details affecting new construction and make necessary approved adjustments prior to construction or ordering of materials. Such variations shall not be cause for additional compensation for a change in scope of the work, however, the Contractor will be paid for the quantity actually furnished at the unit price bid for the work.

Existing structural steel that will be in contact with new structural steel shall be cleaned and painted prior to erection as required by the GBSP "Cleaning and Painting Contact Surface Areas of Existing Steel Structures".

All structural steel shall be hot-dip galvanized. See Special Provisions for "Hot Dip Galvanizing For Structural Steel."

Cost of removal and re-installation of all members necessary to complete the work as detailed on the plans and as specified in the Special Provisions shall be included with Furnishing and Erecting Structural Steel.

**BILL OF MATERIAL**

Structure	Item	Unit	Total
057-0152	Structural Steel Repair*	Pound	3250
	Furnishing and Erecting Structural Steel	Pound	3780
	Structural Steel Removal	Pound	3780
	Stud Shear Connectors	Each	216
057-0153	Structural Steel Repair*	Pound	3630
	Furnishing and Erecting Structural Steel	Pound	4410
	Structural Steel Removal	Pound	4410
	Stud Shear Connectors	Each	378

\* Beam End Repairs only

Note:  
For shear stud locations, see Sheets 13 and 15 of 26.

MODEL: Beam End Repairs  
FILE NAME: P:\Effingham\3454 - PTB 189 IDOT D5 VAVWork Order #6\Cadd\Sheet\152 & 153\0570D64\_0152\_0153\_Combined.dgn  
12/6/2021 7:12:47 AM



USER NAME =	DESIGNED - KAS	REVISED -
PLOT SCALE =	CHECKED - TJZ	REVISED -
PLOT DATE =	DRAWN - DWS	REVISED -
	CHECKED - KAS	REVISED -

STATE OF ILLINOIS  
DEPARTMENT OF TRANSPORTATION

DIAPHRAGM REPLACEMENT & BEAM END REPAIR LOCATIONS  
S.N. 057-0152 (SB) & S.N. 057-0153 (NB)

SHEET 18 OF 26 SHEETS

F.A.I. RTE.	SECTION	COUNTY	TOTAL SHEETS	SHEET NO.
55	(57-1,57-2)BDS	MCLEAN	88	38
			CONTRACT NO. 70D64	
		ILLINOIS FED. AID PROJECT		

MODEL: Beam End Details  
 FILE NAME: P:\Effingham\3454 - PTB\_189\_IDOT D5 V-VIWork Order #6\Cadd\Sheet\152 & 153\152\0570D64\_0152\_0153\_Combined.dgn

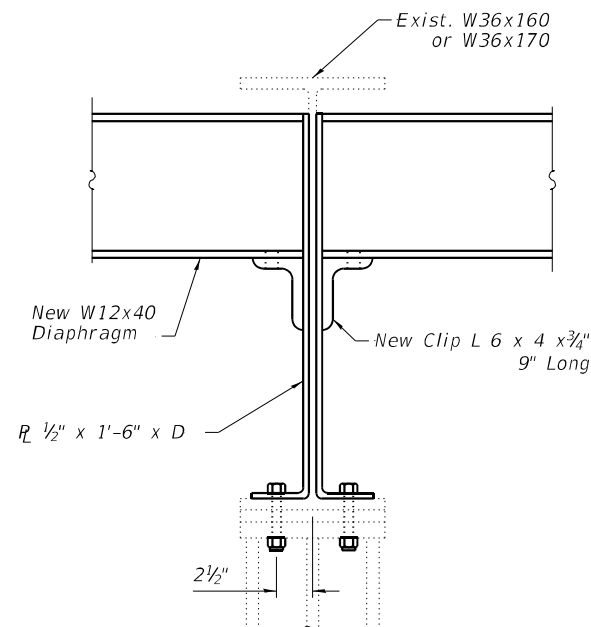
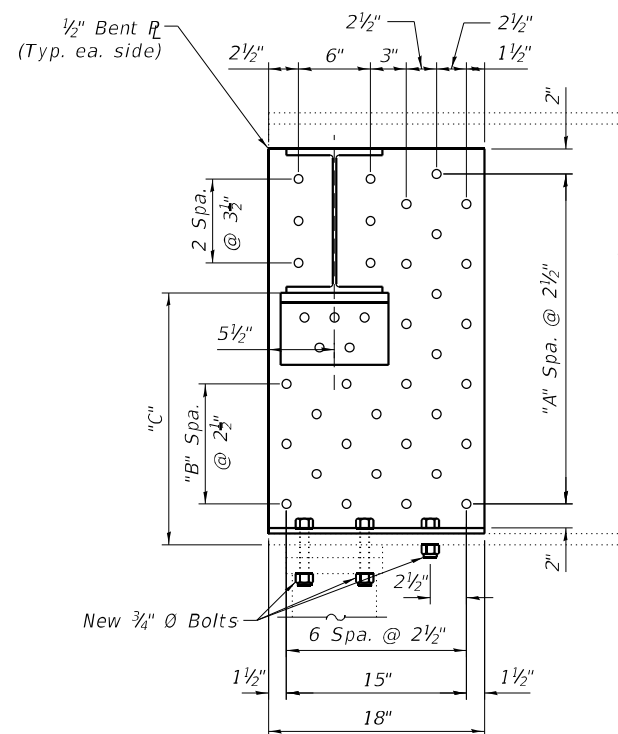

**BEAM END REPAIR**

(Diaphragm lengths vary. See Sheet 18 of 26)

Bridge Number	Beam Number	North Abutment				South Abutment			
		A	B	C	D	A	B	C	D
057-0152	1	11	4	1'-9"	3'-1 1/2"	11	4	1'-9"	3'-1 1/2"
	2	11	3	1'-7 3/4"	3'-1 1/2"	11	3	1'-7 1/4"	3'-1 1/2"
	3	10	3	1'-6 1/2"	2'-11"	10	2	1'-5 1/4"	2'-11"
	4	10	2	1'-5 1/2"	2'-11"	9	2	1'-4"	2'-8 1/2"
	5	10	2	1'-4 1/2"	2'-11"	9	1	1'-2 3/4"	2'-8 1/2"
	6	10	2	1'-5 1/2"	2'-11"	9	2	1'-3 3/4"	2'-8 1/2"
	7	10	3	1'-6 1/2"	2'-11"	10	2	1'-4 3/4"	2'-11"
	8	11	3	1'-7 3/4"	3'-1 1/2"	10	3	1'-6"	2'-11"
057-0153	1	10	2	1'-5 1/4"	2'-11"	10	2	1'-4 1/2"	2'-11"
	2	9	2	1'-4"	2'-8 1/2"	9	2	1'-3 1/4"	2'-8 1/2"
	3	9	1	1'-2 3/4"	2'-8 1/2"	9	1	1'-2"	2'-8 1/2"
	4	9	1	1'-2 1/2"	2'-8 1/2"	9	1	1'-3 3/4"	2'-8 1/2"
	5	9	2	1'-3 3/4"	2'-8 1/2"	9	1	1'-3"	2'-8 1/2"
	6	10	2	1'-5"	2'-11"	10	2	1'-4 1/2"	2'-11"
	7	10	3	1'-6 1/2"	2'-11"	10	3	1'-6"	2'-11"
	8	11	3	1'-8"	3'-1 1/2"	11	3	1'-7 1/2"	3'-1 1/2"
	9	11	4	1'-9"	3'-1 1/2"	11	4	1'-9"	3'-1 1/2"

Notes:

All structural steel shall be AASHTO M270 Grade 36, unless otherwise noted.

Cost of furnishing and erecting steel diaphragms and diaphragm support angles shall be included with Furnishing and Erecting Structural Steel.

Cost of furnishing and erecting steel for beam end repairs shall be included with Structural Steel Repair.

Cost of drilling holes in existing steel members is included with Structural Steel Repair.

Removal of existing diaphragm support angles and diaphragms shall be included in Structural Steel Removal.

Existing L 6"x4"x3/4" shall be removed by the air-arc method and grind smooth all weld material remaining on the web.

Omit diaphragm support angle on outside faces of exterior beams.

All holes in existing steel shall be field drilled using shop drilled holes in new steel as a template, except as noted. Holes shall be 1 3/16" Ø for 3/4" Ø bolts.

All fasteners shall be 3/4" Ø high strength bolts.

Plan dimensions and details relative to existing plans are subject to nominal construction variations. The Contractor shall field verify existing dimensions and details affecting new construction and make necessary approved adjustments prior to construction or ordering of materials. Such variations shall not be cause for additional compensation for a change in scope of the work, however, the Contractor will be paid for the quantity actually furnished at the unit price bid for the work.

Existing structural steel that will be in contact with new structural steel shall be cleaned and painted prior to erection as required by the special provision "Cleaning and Painting Contact Surface Areas of Existing Steel Structures."

All new structural steel shall be hot-dip galvanized. See Special Provisions for "Hot Dip Galvanizing for Structural Steel."

Installation of new diaphragms shall not commence until all bolts for new web plates and clip angles are fully tightened.



CIVIL DESIGN, INC.  
 WBE / DBE  
 EFFINGHAM, IL  
 LICENSE # 184.003222

USER NAME =	DESIGNED - KAS	REVISED -
	CHECKED - TJZ	REVISED -
PLOT SCALE =	DRAWN - DWS	REVISED -
PLOT DATE =	CHECKED - KAS	REVISED -

STATE OF ILLINOIS  
 DEPARTMENT OF TRANSPORTATION

DIAPHRAGM REPLACEMENT & BEAM END REPAIR DETAILS  
 S.N. 057-0152 (SB) & S.N. 057-0153 (NB)

SHEET 19 OF 26 SHEETS

F.A.I. RTE.	SECTION	COUNTY	TOTAL SHEETS	SHEET NO.
55	(57-1,57-2)BDS	MCLEAN	88	39
			CONTRACT NO. 70D64	
			ILLINOIS FED. AID PROJECT	



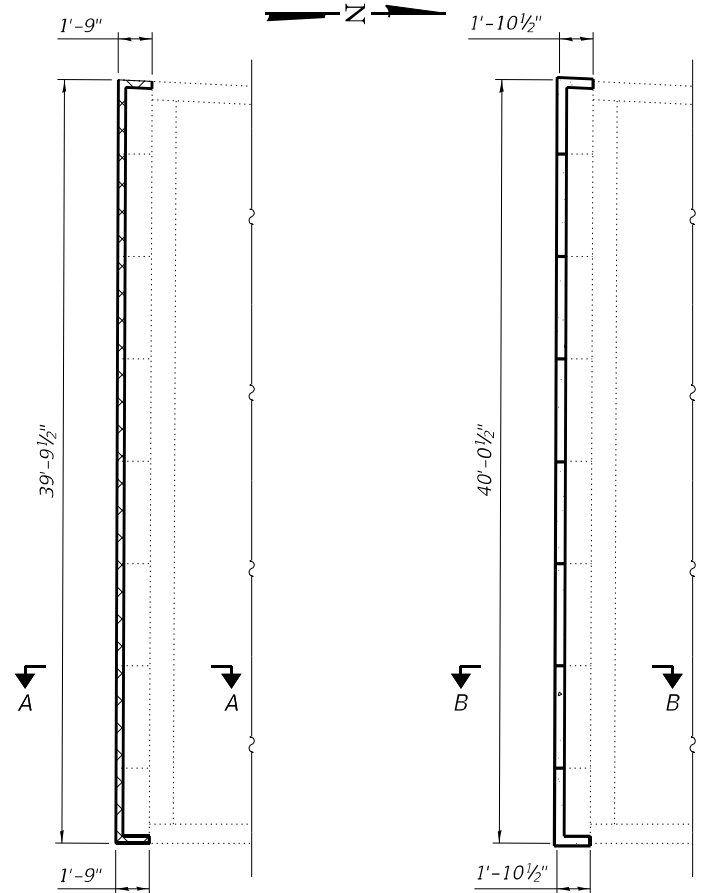

**SUBSTRUCTURE  
REMOVAL PLAN**

(North Abutment)

**PROPOSED CONCRETE  
STRUCTURES PLAN**

(North Abutment)

Epoxy grout #4- d4(E)  
Bars at 24\"/>

**DETAIL A**

Epoxy grout bars in 9\"/>

Concrete Removal

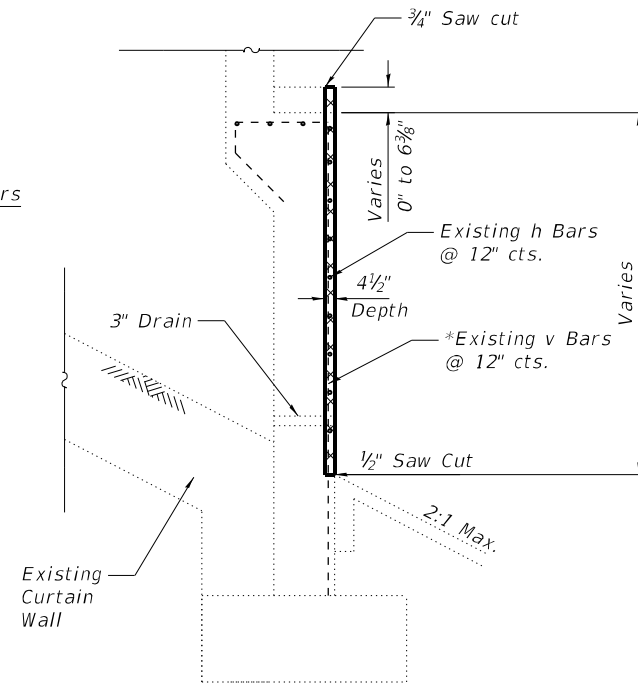

**SECTION A-A**

\*\* Existing abutment drains shall be extended thru proposed abutment face with PVC. Estimated pipe length 2'-0\"/>

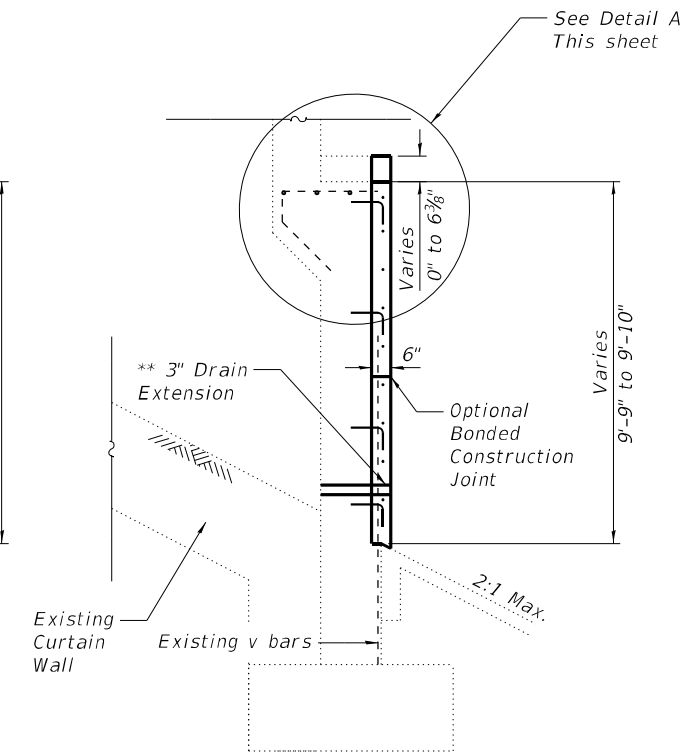

**SECTION B-B**

**BILL OF MATERIAL**

(North Abutment)

Bar	No.	Size	Length	Shape	
h(E)	20	#5	22'-6"		
d4(E)	110	#4	1'-8"		
v(E)	44	#5	8'-3"		
Reinforcement Bars, Epoxy Coated				Pound	970
Concrete Removal				Cu. Yd.	5.9
Concrete Structures				Cu. Yd.	7.8
Protective Coat				Sq. Yd.	51

**NOTES:**

Plan dimensions and details relative to existing plans are subject to nominal construction variations. The Contractor shall field verify existing dimensions and details affecting new construction and make necessary approved adjustments prior to construction or ordering of materials. Such variations shall not be cause for additional compensation for a change in scope of work, however, the contractor will be paid for the quantity actually furnished at the unit price bid for the work.

The cost of epoxy grouting bars shall be included with Reinforcement Bars, Epoxy Coated.

Reinforcement bars designated (E) shall be epoxy coated.

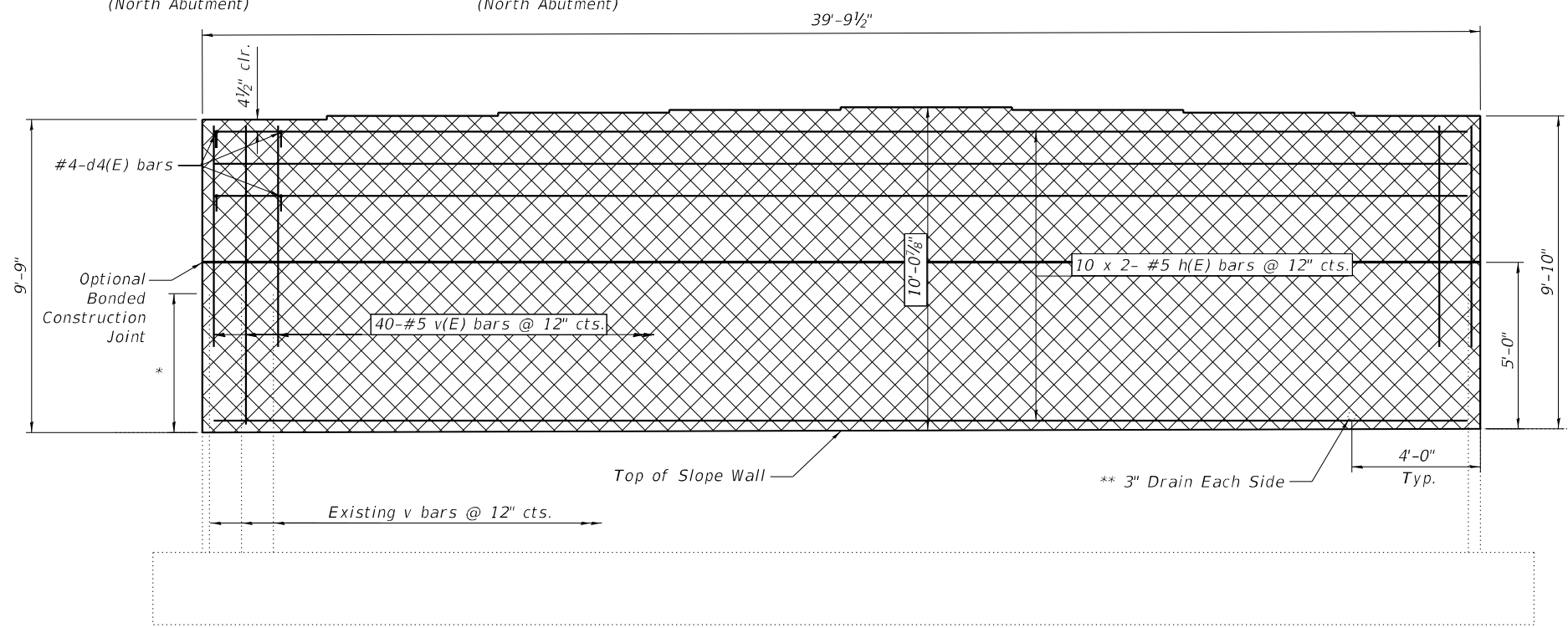

**ELEVATION**

\* Cutoff height of existing v bars above concrete removal line is 4'-4\"/>

Bar	Bar Size	Lap Length
h(E)	#5	2'-7"
v(E)	#5	2'-7"

MODEL: North Abutment Details  
FILE NAME: P:\Effingham\3454 - PTB 189 IDOT D5 V-V\Work Order #6\Cadd\Sheet\152 & 153\0570D64\_0152\_0153\_Combined.dgn  
12/6/2021 7:12:49 AM



USER NAME =	DESIGNED - KAS	REVISED -
PLOT SCALE =	CHECKED - TJZ	REVISED -
PLOT DATE =	DRAWN - DWS	REVISED -
	CHECKED - KAS	REVISED -

**STATE OF ILLINOIS  
DEPARTMENT OF TRANSPORTATION**

**NORTH ABUTMENT REPAIRS  
S.N. 057-0152 (SB)**

SHEET 20 OF 26 SHEETS

F.A.I. RTE.	SECTION	COUNTY	TOTAL SHEETS	SHEET NO.
55	(57-1.57-2)BDS	MCLEAN	88	40
CONTRACT NO. 70D64				
ILLINOIS FED. AID PROJECT				

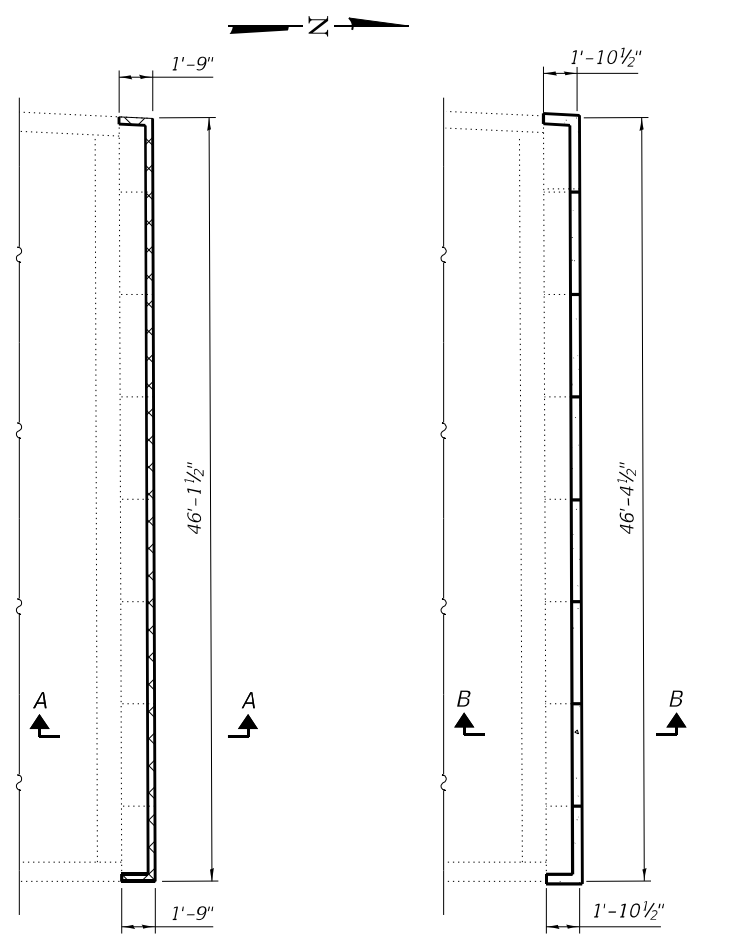

**SUBSTRUCTURE REMOVAL PLAN**  
(South Abutment)

**PROPOSED CONCRETE STRUCTURES PLAN**  
(South Abutment)

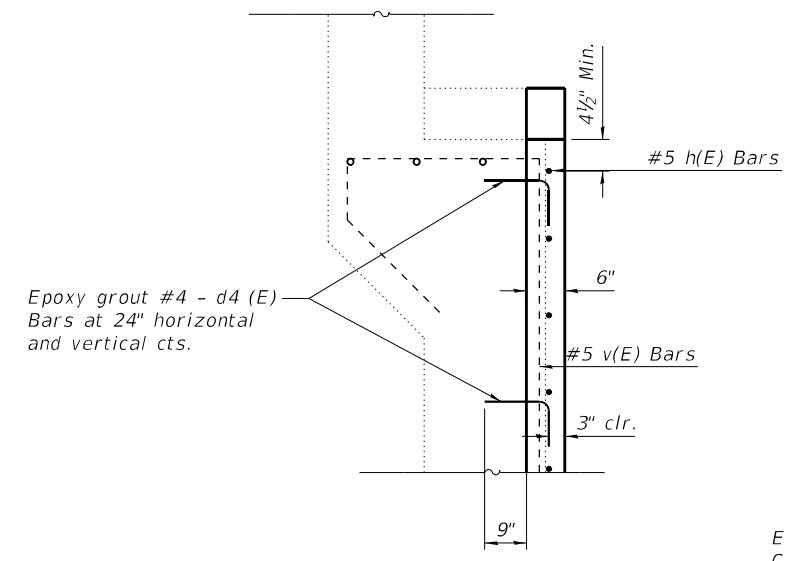

**DETAIL A**  
Epoxy grout bars in 9" min. holes according to Article 584 of the Standard Specifications.

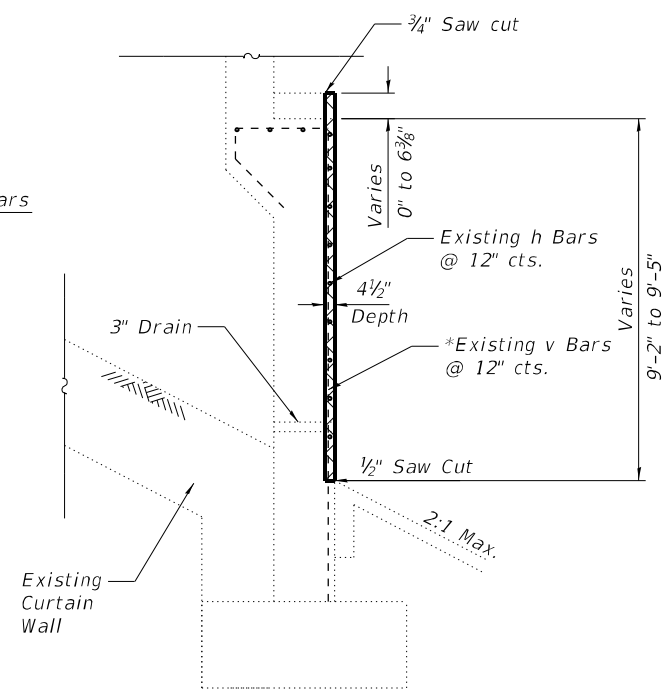

**SECTION A-A**

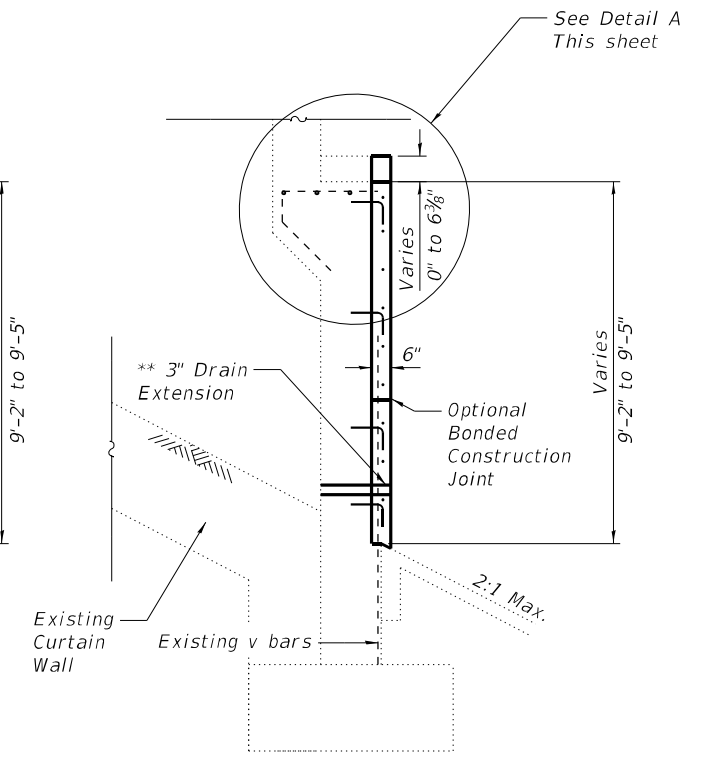

**SECTION B-B**

\*\* Existing abutment drains shall be extended thru proposed abutment face with PVC. Estimated pipe length 2'-0" to extend thru the existing abutment face into the vaulted abutment, pipe drain cost included with Concrete Structures.

Concrete Removal

**BILL OF MATERIAL**  
(South Abutment)

Bar	No.	Size	Length	Shape	
h1(E)	20	#5	25'-8"	—	
d4(E)	125	#4	1'-8"	└	
v1(E)	47	#5	8'-3"	—	
Reinforcement Bars, Epoxy Coated				Pound	1080
Concrete Removal				Cu. Yd.	6.4
Concrete Structures				Cu. Yd.	8.6
Protective Coat				Sq. Yd.	56

**NOTES:**

Plan dimensions and details relative to existing plans are subject to nominal construction variations. The Contractor shall field verify existing dimensions and details affecting new construction and make necessary approved adjustments prior to construction or ordering of materials. Such variations shall not be cause for additional compensation for a change in scope of work, however, the contractor will be paid for the quantity actually furnished at the unit price bid for the work.

The cost of epoxy grouting bars shall be included with Reinforcement Bars, Epoxy Coated.

Reinforcement bars designated (E) shall be epoxy coated.

\* Cutoff height of existing v bars above concrete removal line is 4'-4".

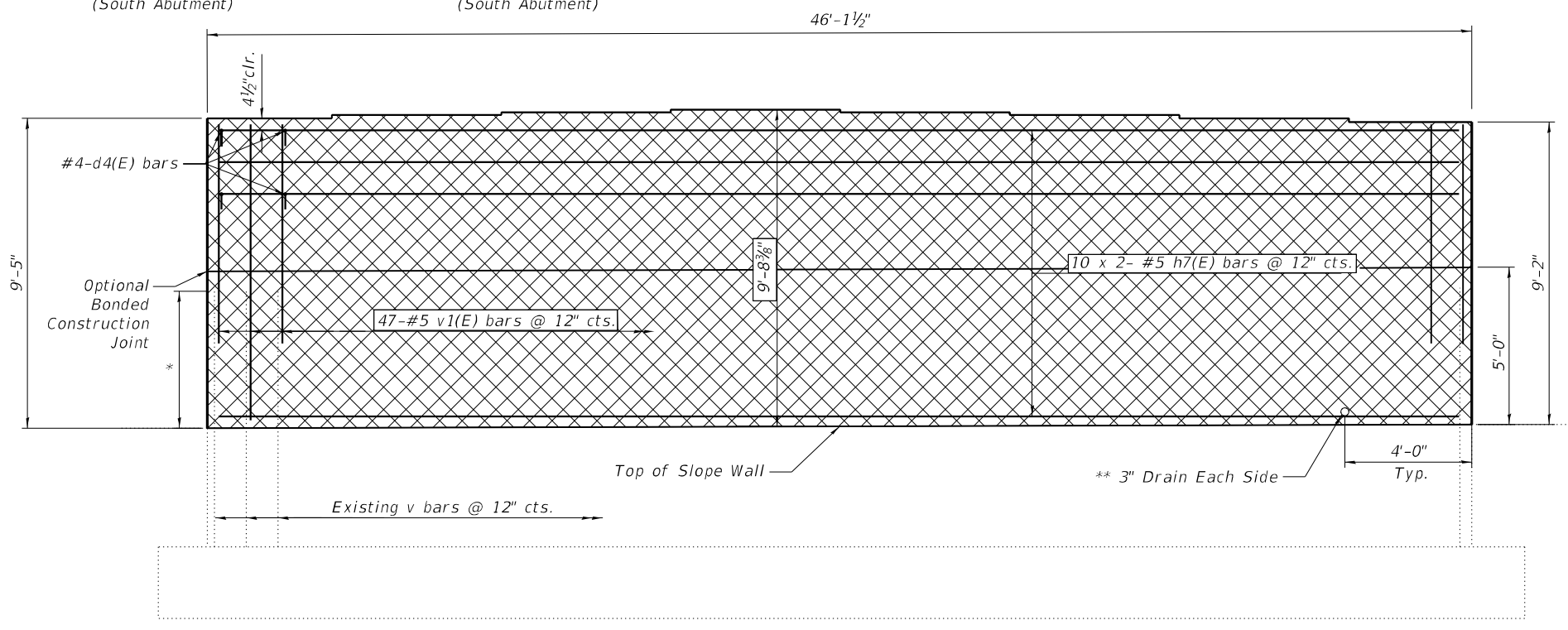

**ELEVATION**

Bar	Bar Size	Lap Length
h(E)	#5	2'-7"
v(E)	#5	2'-7"

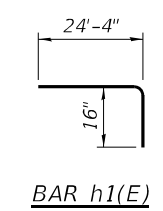

MODEL: South Abutment Repairs  
FILE NAME: P:\Effingham\3454 - PTB 189 IDOT D5 VAVWork Order #6\Cadd\Sheet\152 & 153\0570D64\_0152\_0153\_Combined.dgn  
12/6/2021 7:12:50 AM

**CIVIL DESIGN, INC.**  
WBE / DBE  
EFFINGHAM, IL  
LICENSE # 184.003222

USER NAME =	DESIGNED - KAS	REVISED -
PLOT SCALE =	CHECKED - TJZ	REVISED -
PLOT DATE =	DRAWN - DWS	REVISED -
	CHECKED - KAS	REVISED -

**STATE OF ILLINOIS**  
**DEPARTMENT OF TRANSPORTATION**

**SOUTH ABUTMENT REPAIRS**  
**S.N. 057-0152 (SB)**

SHEET 21 OF 26 SHEETS

F.A.I. RTE.	SECTION	COUNTY	TOTAL SHEETS	SHEET NO.
55	(57-1,57-2)BDS	MCCLEAN	88	41
CONTRACT NO. 70D64				
ILLINOIS FED. AID PROJECT				

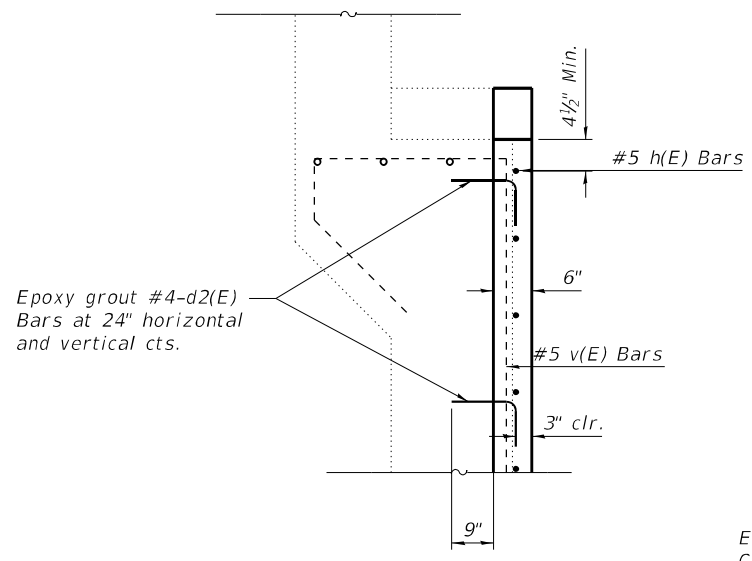
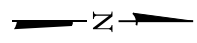
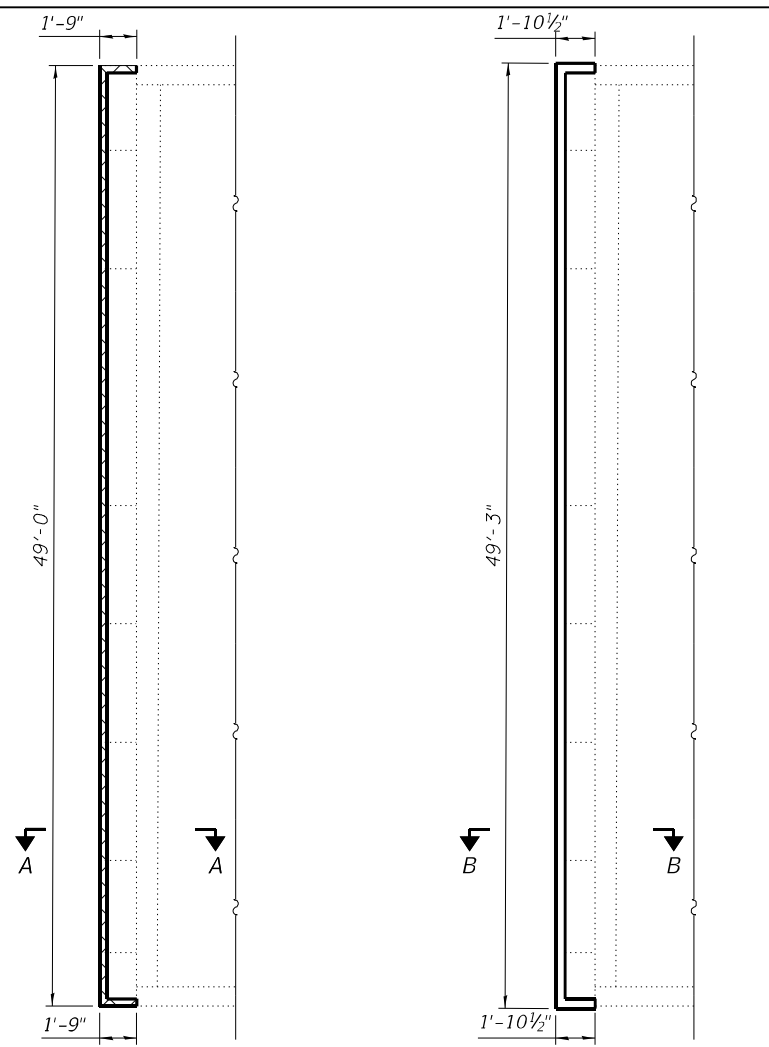

Bar	Bar Size	Lap Length
h(E)	#5	2'-7"
v(E)	#5	2'-7"

Concrete Removal

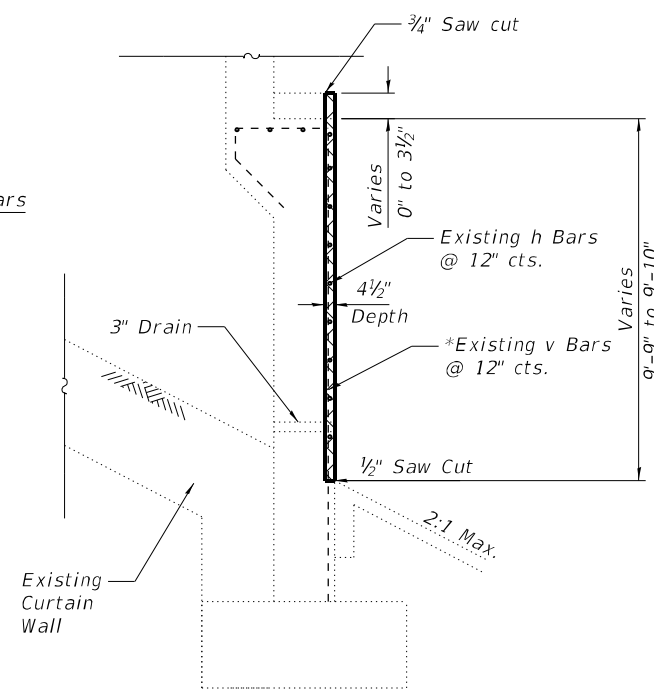

**SECTION A-A**

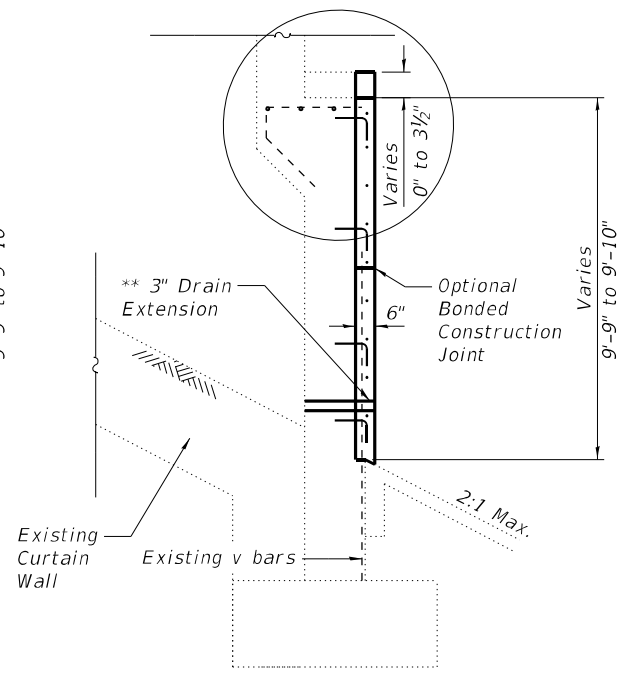

**SECTION B-B**

\*\* Existing abutment drains shall be extended thru proposed abutment face with PVC. Estimated pipe length 2'-0" to extend thru the existing abutment face into the vaulted abutment, pipe drain cost included with Concrete Structures.

\* Cutoff height of existing v bars above concrete removal line is 4'-4".

**BILL OF MATERIAL**

(North Abutment)

Bar	No.	Size	Length	Shape
h3(E)	20	#5	27'-4"	
d2(E)	135	#4	1'-8"	
v(E)	53	#5	8'-3"	
Reinforcement Bars, Epoxy Coated		Pound		1180
Concrete Removal		Cu. Yd.		7.2
Concrete Structures		Cu. Yd.		9.7
Protective Coat		Sq. Yd.		62

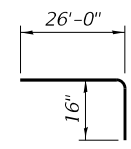

**BAR h3(E)**

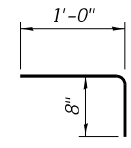

**BAR d2(E)**

**NOTES:**

Plan dimensions and details relative to existing plans are subject to nominal construction variations. The Contractor shall field verify existing dimensions and details affecting new construction and make necessary approved adjustments prior to construction or ordering of materials. Such variations shall not be cause for additional compensation for a change in scope of work, however, the contractor will be paid for the quantity actually furnished at the unit price bid for the work.

The cost of epoxy grouting bars shall be included with Reinforcement Bars, Epoxy Coated.

Reinforcement bars designated (E) shall be epoxy coated.

MODEL: North Abutment Repairs  
FILE NAME: P:\Effingham\3454 - PTB 189 IDOT D5 VAVWork Order #6\Cadd\Sheet\152 & 153\DOT570D64\_0152\_0153\_Combined.dgn  
12/6/2021 7:12:51 AM

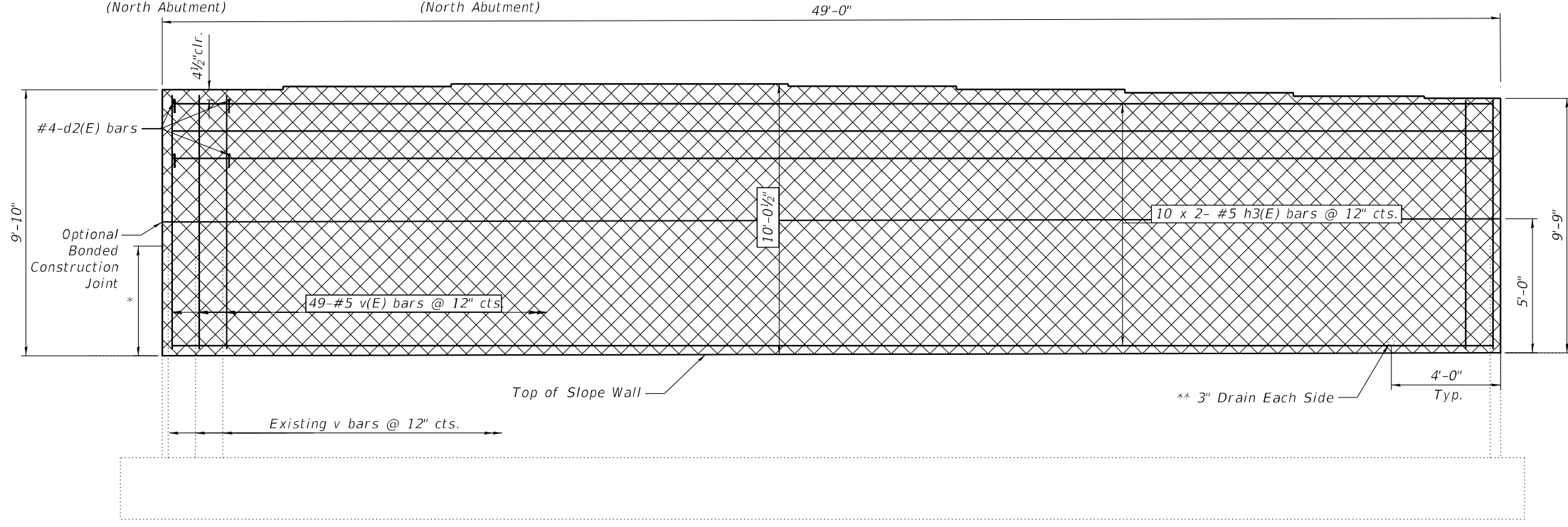

**ELEVATION**



**CIVIL DESIGN, INC.**  
WBE / DBE  
EFFINGHAM, IL  
LICENSE #184.003222

USER NAME =	DESIGNED - KAS	REVISED -
PLOT SCALE =	CHECKED - TJZ	REVISED -
PLOT DATE =	DRAWN - DWS	REVISED -
	CHECKED - KAS	REVISED -

**STATE OF ILLINOIS**  
**DEPARTMENT OF TRANSPORTATION**

**NORTH ABUTMENT REPAIRS**  
**S.N. 057-0153 (NB)**

SHEET 22 OF 26 SHEETS

F.A.I. RTE.	SECTION	COUNTY	TOTAL SHEETS	SHEET NO.
55	(57-1,57-2)BDS	MCCLEAN	88	42
			CONTRACT NO. 70D64	
ILLINOIS FED. AID PROJECT				

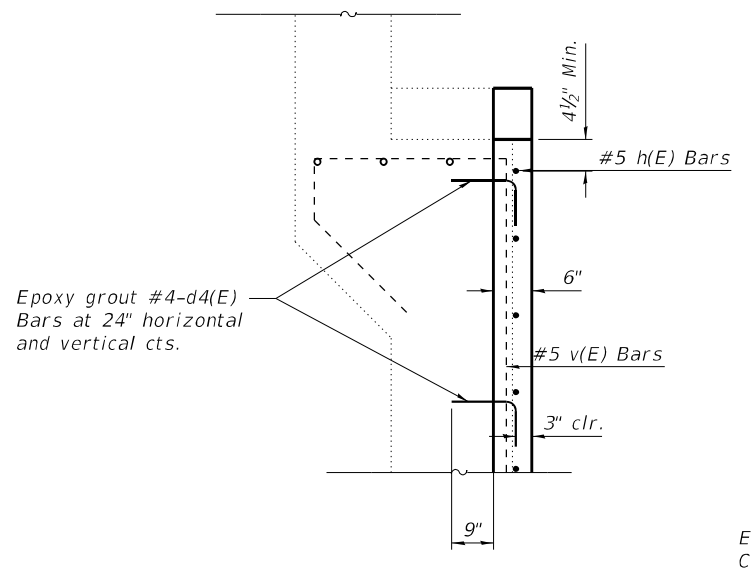
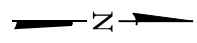
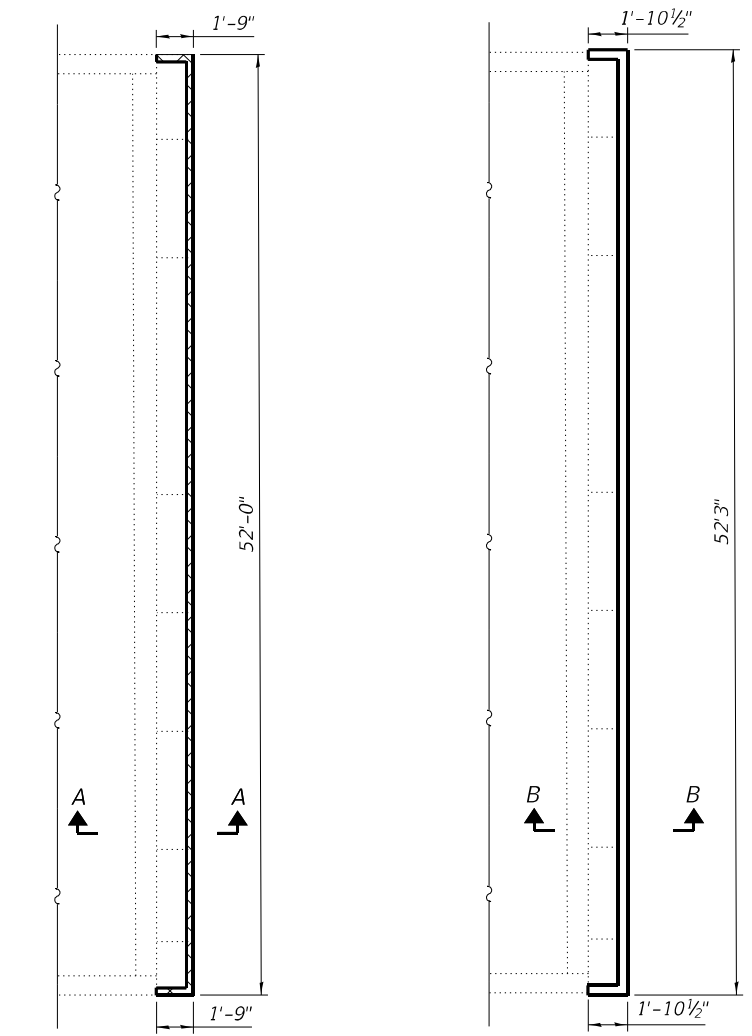

Bar	Bar Size	Lap Length
h(E)	#5	2'-7"
v(E)	#5	2'-7"

Concrete Removal

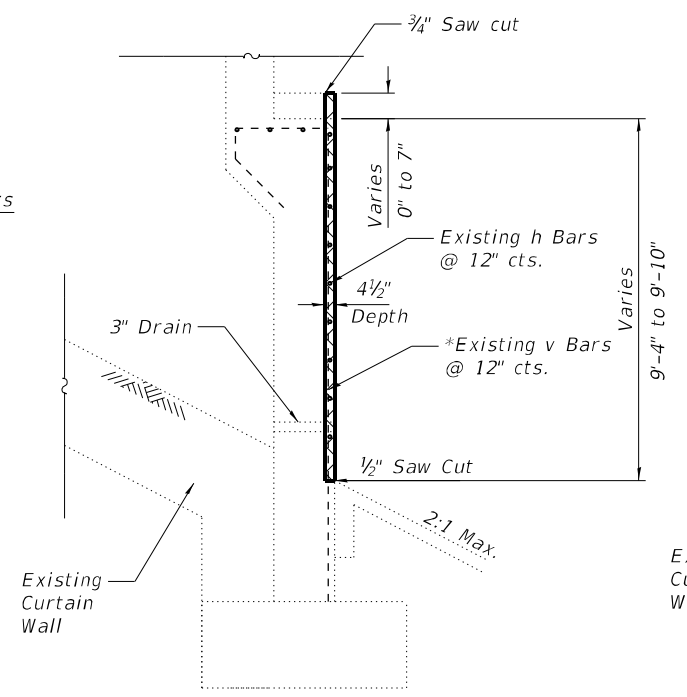

\*\* Existing abutment drains shall be extended thru proposed abutment face with PVC. Estimated pipe length 2'-0" to extend thru the existing abutment face into the vaulted abutment, pipe drain cost included with Concrete Structures.

\* Cutoff height of existing v bars above concrete removal line is 4'-4".

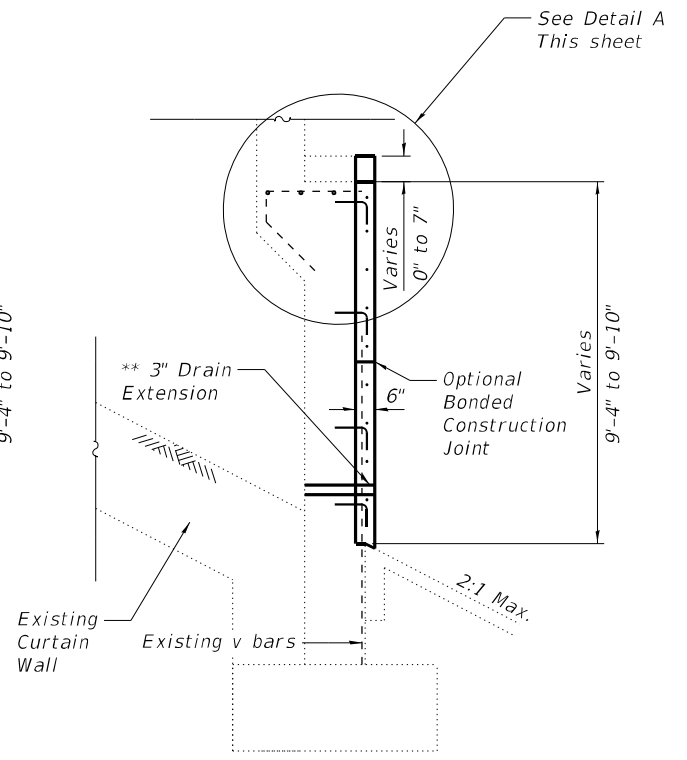

**SECTION B-B**

**BILL OF MATERIAL**  
(South Abutment)

Bar	No.	Size	Length	Shape	
h4(E)	20	#5	28'-10"		
d4(E)	140	#4	1'-8"		
v2(E)	44	#5	8'-3"		
Reinforcement Bars, Epoxy Coated				Pound	1140
Concrete Removal				Cu. Yd.	7.3
Concrete Structures				Cu. Yd.	9.8
Protective Coat				Sq. Yd.	63

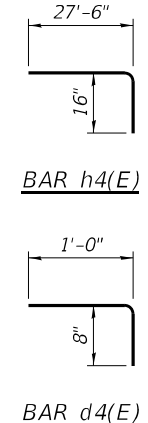

**NOTES:**

Plan dimensions and details relative to existing plans are subject to nominal construction variations. The Contractor shall field verify existing dimensions and details affecting new construction and make necessary approved adjustments prior to construction or ordering of materials. Such variations shall not be cause for additional compensation for a change in scope of work, however, the contractor will be paid for the quantity actually furnished at the unit price bid for the work.

The cost of epoxy grouting bars shall be included with Reinforcement Bars, Epoxy Coated.

Reinforcement bars designated (E) shall be epoxy coated.

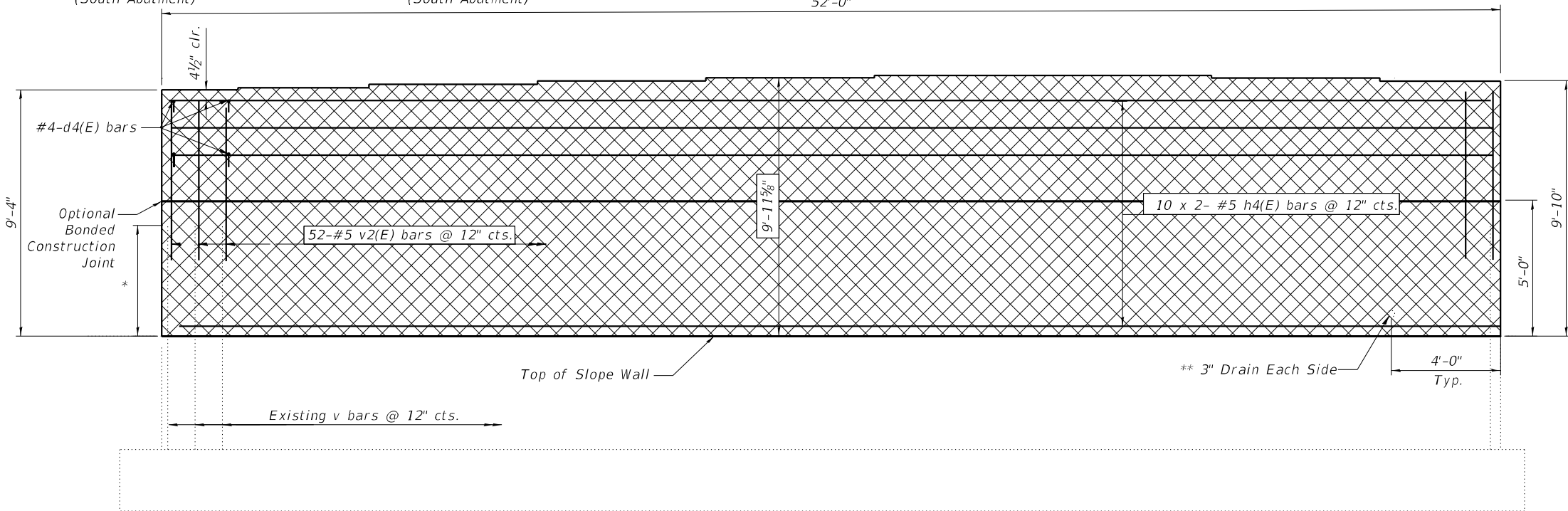

MODEL: South Abutment repairs-2  
FILE NAME: P:\Effingham\3454 - PTB 189 IDOT D5 VAVWork Order #6\Cadd\Sheet\152 & 153\DOT D5 VAVWork Order #6\Cadd\Sheet\152\_0152\_0153\_Combined.dgn  
12/6/2021 7:12:52 AM



**CIVIL DESIGN, INC.**  
WBE / DBE  
EFFINGHAM, IL  
LICENSE # 184.003222

USER NAME	DESIGNED	REVISIONS
-	KAS	-
-	TJZ	-
-	DWS	-
-	KAS	-

**STATE OF ILLINOIS**  
**DEPARTMENT OF TRANSPORTATION**

**SOUTH ABUTMENT REPAIRS**  
**S.N. 057-0153 (NB)**

SHEET 23 OF 26 SHEETS

F.A.I. RTE.	SECTION	COUNTY	TOTAL SHEETS	SHEET NO.
55	(57-1,57-2)BDS	MCLEAN	88	43
				CONTRACT NO. 70D64
ILLINOIS FED. AID PROJECT				

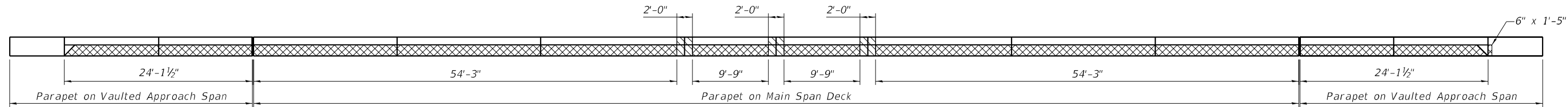

WEST PARAPET ELEVATION

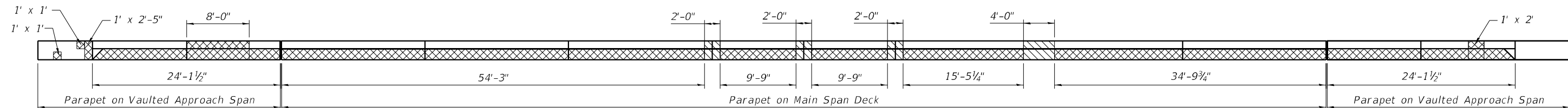

EAST PARAPET ELEVATION

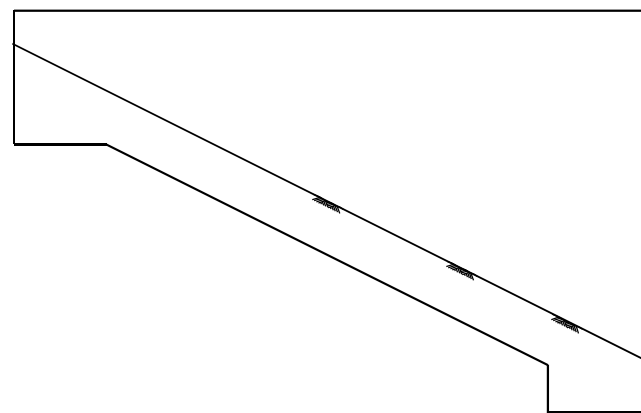

SOUTH ABUTMENT EAST CURTAIN WALL

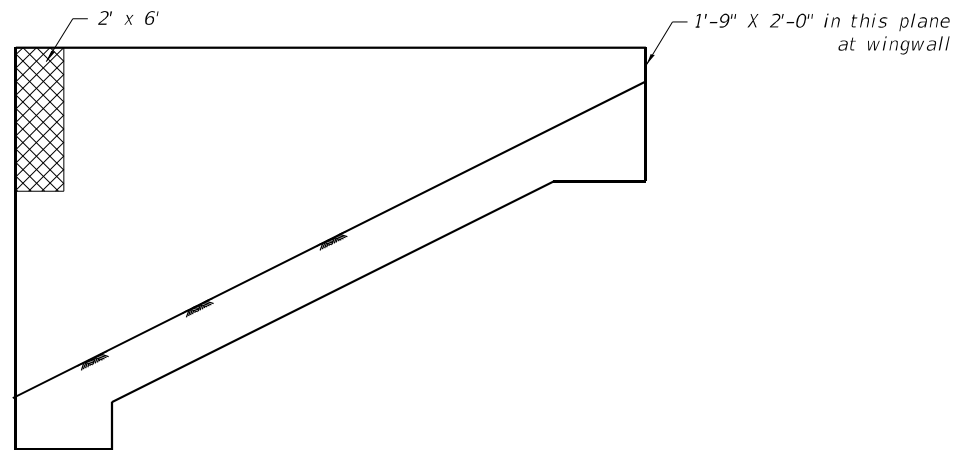

SOUTH ABUTMENT WEST CURTAIN WALL

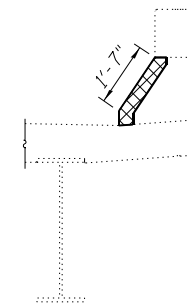

SECTION THRU PARAPET

Showing Typical Removal Limits for Structural Repair of Concrete on Parapets

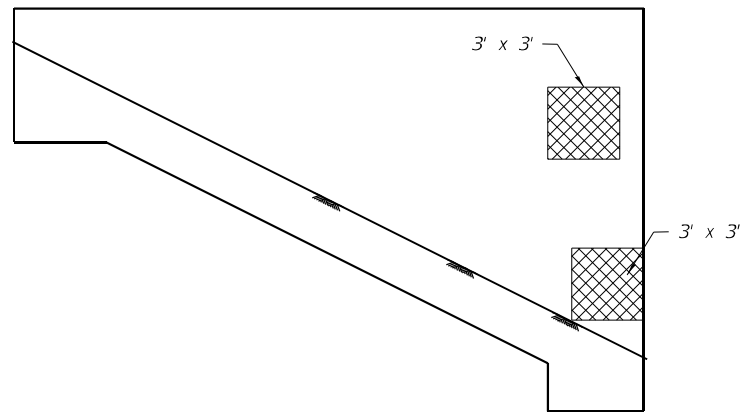

NORTH ABUTMENT WEST CURTAIN WALL

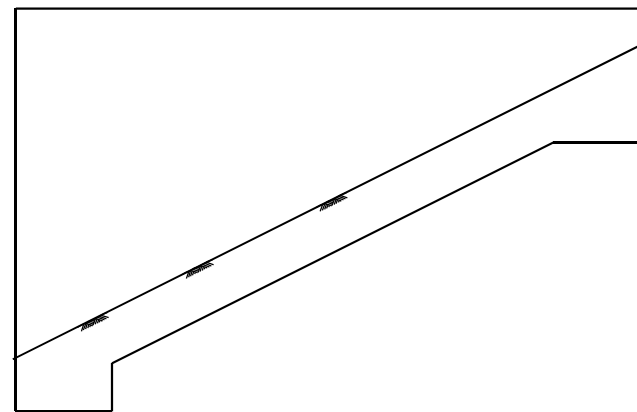

NORTH ABUTMENT EAST CURTAIN WALL

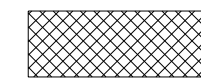

Structural Repair of Concrete  
Depth equal to or Less than 5"



Parapet Replacement-See Parapet Repair Sheet, Sheet 11 of 26

Note:  
See Special Provision for Structural Repair of Concrete.

BILL OF MATERIAL

Structure	Item	Unit	Total
057-0152	Structural Repair of Concrete, Depth Equal to or Less than 5"	Sq. Ft.	626

MODEL: Shallow Repairs  
FILE NAME: P:\Effingham\3454 - PTB 189 IDOT D5 V-V\Work Order #6\Cadd\Sheet\152 & 153\0570D64\_0152\_0153\_Combined.dgn



USER NAME =	DESIGNED - KAS	REVISED -
	CHECKED - TJZ	REVISED -
PLOT SCALE =	DRAWN - DWS	REVISED -
PLOT DATE =	CHECKED - KAS	REVISED -

STATE OF ILLINOIS  
DEPARTMENT OF TRANSPORTATION

SHALLOW CONCRETE REPAIR PLAN  
S.N. 057-0152 (SB)

SHEET 24 OF 26 SHEETS

F.A.I. RTE.	SECTION	COUNTY	TOTAL SHEETS	SHEET NO.
55	(57-1,57-2)BDS	MCLEAN	88	44
			CONTRACT NO. 70D64	
		ILLINOIS FED. AID PROJECT		

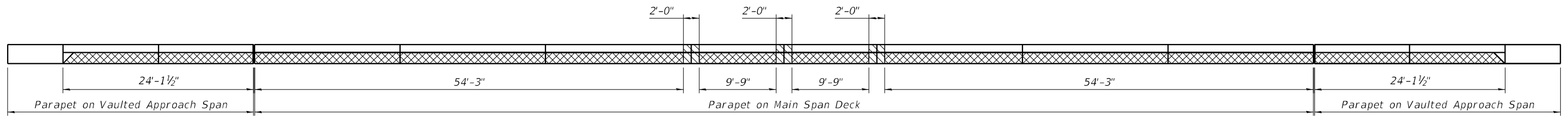

WEST PARAPET ELEVATION

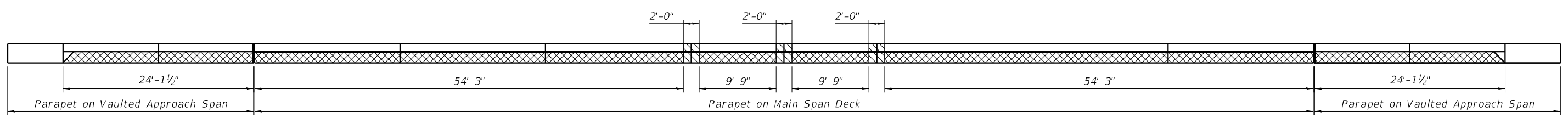

EAST PARAPET ELEVATION

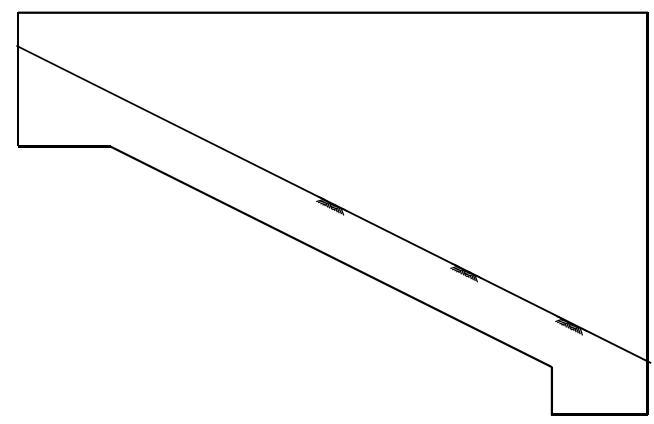

SOUTH ABUTMENT EAST CURTAIN WALL

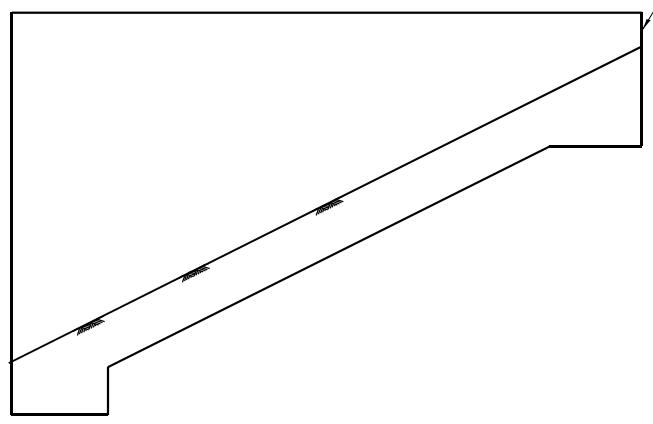

SOUTH ABUTMENT WEST CURTAIN WALL

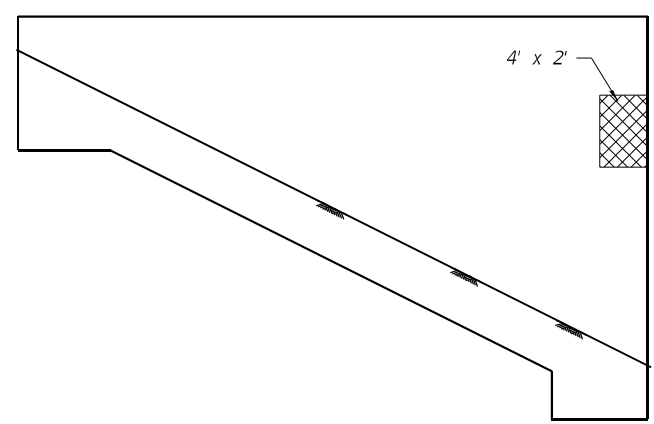

NORTH ABUTMENT WEST CURTAIN WALL

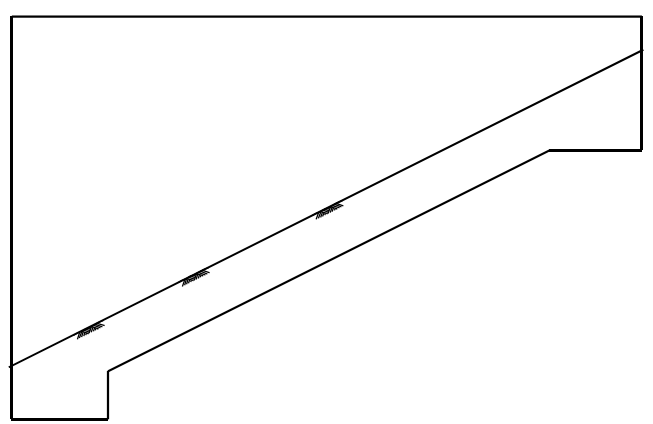

NORTH ABUTMENT EAST CURTAIN WALL

1'-0" X 2'-0" in this plane at wingwall

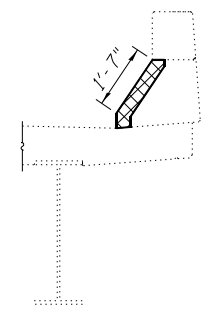

SECTION THRU PARAPET

Showing Typical Removal Limits for Structural Repair of Concrete on Parapets



Structural Repair of Concrete  
Depth equal to or Less than 5"



Parapet Replacement-See Parapet Repair Sheet, Sheet 11 of 26

Note:

See Special Provision for Structural Repair of Concrete.

BILL OF MATERIAL

Structure	Item	Unit	Total
057-0153	Structural Repair of Concrete, Depth Equal to or Less than 5"	Sq. Ft.	600

MODEL: Shallow Repair  
FILE NAME: P:\Effingham\3454 - PTB 189 IDOT D5 V-VI\Work Order #6\Cadd\Sheet\152 & 153\0570D64\_0152\_0153\_Combined.dgn  
10/21/2021 2:52:51 PM



CIVIL DESIGN, INC.  
WBE / DBE  
EFFINGHAM, IL  
LICENSE # 184.003222

USER NAME =	DESIGNED - KAS	REVISED -
PLOT SCALE =	CHECKED - TJZ	REVISED -
PLOT DATE =	DRAWN - DWS	REVISED -
	CHECKED - KAS	REVISED -

STATE OF ILLINOIS  
DEPARTMENT OF TRANSPORTATION

SHALLOW CONCRETE REPAIR PLAN  
S.N. 057-0153 (NB)

SHEET 25 OF 26 SHEETS

F.A.I. RTE.	SECTION	COUNTY	TOTAL SHEETS	SHEET NO.
55	(57-1,57-2)BDS	MCLEAN	88	45
			CONTRACT NO. 70D64	
		ILLINOIS FED. AID PROJECT		

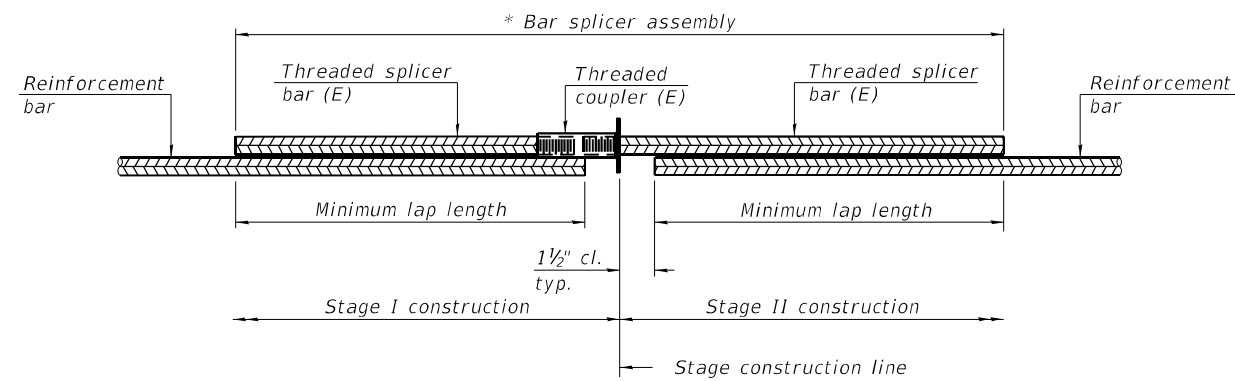

**STANDARD BAR SPLICER ASSEMBLY PLAN**  
(All components shall be provided from one supplier)

Threaded splicer bar length = min. lap length + 1 1/2" + thread length

\* Epoxy not required on Bar Splicer Assembly components used in conjunction with black bars.

Structure	Location	Bar size	No. assemblies required	Minimum lap length
057-0152	Deck End	#6	52	4'-10"
057-0153	Deck End	#6	84	4'-10"

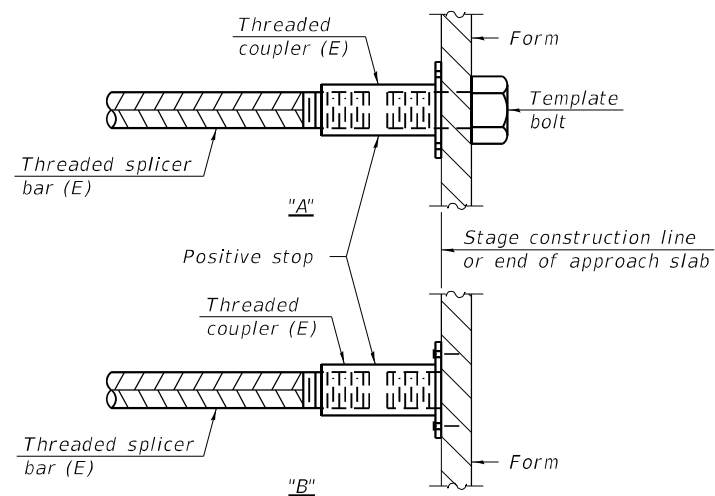

**INSTALLATION AND SETTING METHODS**

"A" : Set bar splicer assembly by means of a template bolt.  
 "B" : Set bar splicer assembly by nailing to wood forms or cementing to steel forms.  
 (E) : Indicates epoxy coating.

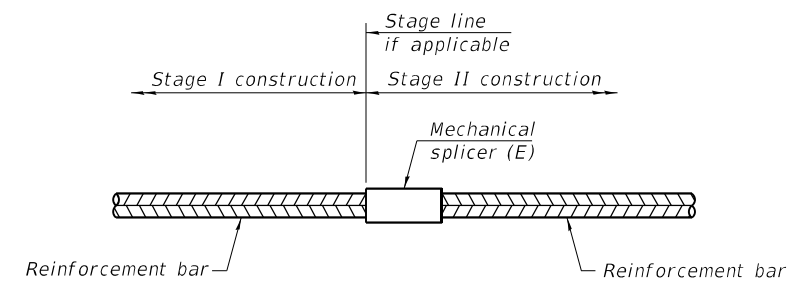

**STANDARD MECHANICAL SPLICER**

Location	Bar size	No. assemblies required

Notes:  
 Splicer bars shall be deformed with threaded ends and have a minimum 60 ksi yield strength.  
 All reinforcement shall be lapped and tied to the splicer bars.  
 Bar splicer assemblies shall be epoxy coated according to the requirements for reinforcement bars. See Section 508 of the Standard Specifications.  
 See approved list of bar splicer assemblies and mechanical splicers for alternatives.

MODEL: BSD  
 FILE NAME: P:\Effingham\3454 - PTB 189 IDOT D5 V-V\Work Order #6\Cadd\Sheet\152 & 153\0570D64\_0152\_0153\_Combined.dgn

BSD-1

1-1-2020



CIVIL DESIGN, INC.  
 WBE / DBE  
 EFFINGHAM, IL  
 LICENSE # 184.003222

USER NAME =	DESIGNED - KAS	REVISED -
	CHECKED - TJZ	REVISED -
PLOT SCALE =	DRAWN - DWS	REVISED -
PLOT DATE =	CHECKED - KAS	REVISED -

STATE OF ILLINOIS  
 DEPARTMENT OF TRANSPORTATION

BAR SPLICER ASSEMBLY AND MECHANICAL SPLICER DETAILS  
 S.N. 057-0152 (SB) & S.N. 057-0153 (NB)

SHEET 26 OF 26 SHEETS

F.A.I. RTE.	SECTION	COUNTY	TOTAL SHEETS	SHEET NO.
55	(57-1,57-2)BDS	MCLEAN	88	46
			CONTRACT NO. 70D64	
ILLINOIS FED. AID PROJECT				

Structure 057-0173 and Structure 057-0174 were originally constructed in 1975 as FAI 55 over Turkey Creek, Contract 30543, Section 57-2B at Station 781+50.00 in McLean County. In 2003, the structures were repaired with Contract 66107 Section (57-1, 57-2)RS. The channel was cleaned out, reshaped, and new rip rap was placed. The I-11 on S. N. 057-0173, bituminous overlay on S.N. 057-0174, and waterproofing membranes were removed and the deck was overlaid with 3" of microsilica concrete. Drains within 10' of piers and abutments were plugged. Gaps between slopewall and abutment were filled in with CLSM. On S.N. 057-0173 repairs were made to piers, abutments, and roadway face of the southwest parapet. On S.N. 057-0174 repairs were made to the southwest and southeast wingwalls and to the north pier. The approach slabs were replaced and a swellable waterproofing barrier was placed between the back of the abutment and the approach pavement on both structures.

The existing structures are three span reinforced concrete slab bridges. The superstructure consists of a nominal 14 1/4" reinforced concrete haunched slab deck with a 3" microsilica wearing surface. The superstructure is supported by two straight stem piers and two stub abutments on concrete piles. The slopes are protected with a concrete slopewall.

The structures have an overall length of 97'-0" from back to back of abutment. The deck has an out to out width of 42'-0", and a deck (clear area) width of 40'-0" from face to face of parapet and rail.

Traffic Barrier Terminal Type 6 Guardrail (Typ.)  
Remove and Re-erect if needed  
to complete Hydro-demolition

Note:  
See Sheet 2 of 11 for Proposed Work,  
Bill of Material, and General Notes.

**DESIGN STRESSES**

**FIELD UNITS**

New Construction  
f'c = 4,000 psi  
fy = 60,000 psi

Existing Structure  
f'c = 1,400 psi  
fs = 20,000 psi

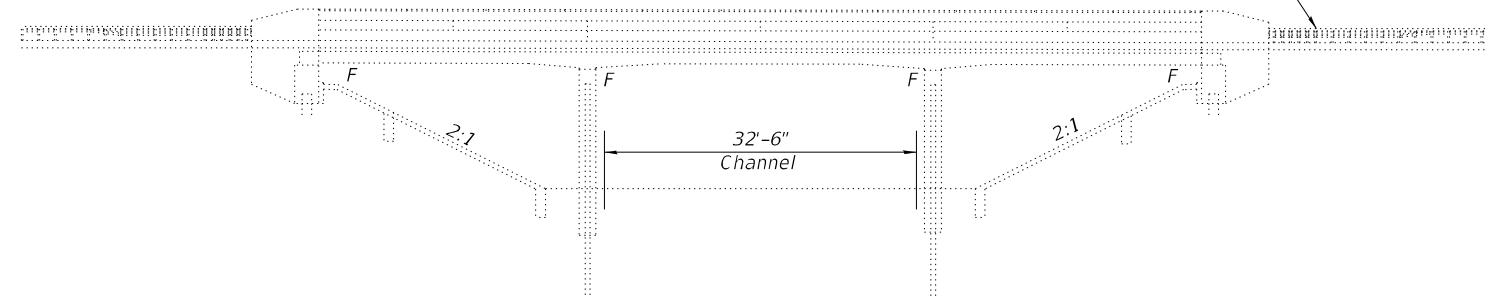

**ELEVATION**

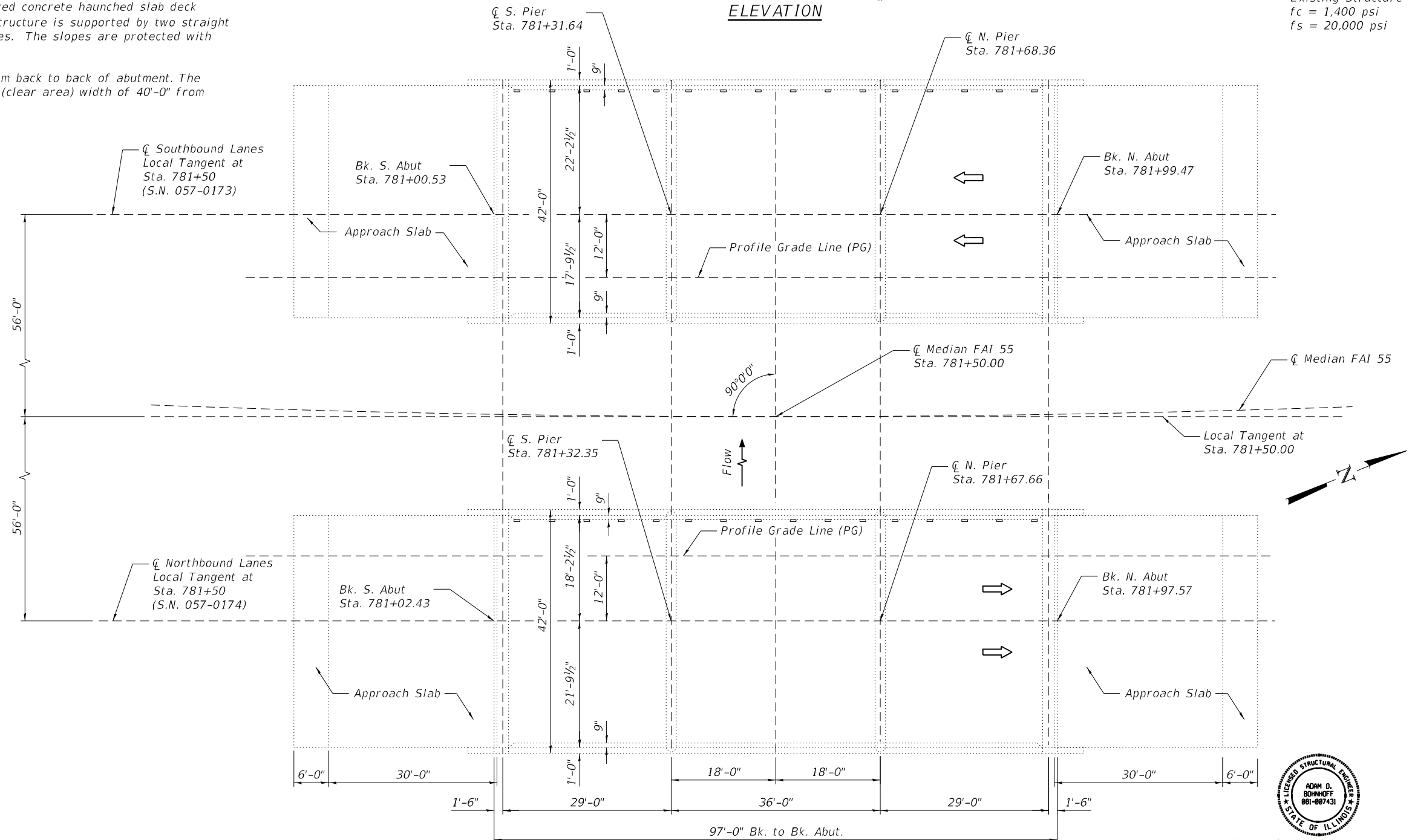

**PLAN**

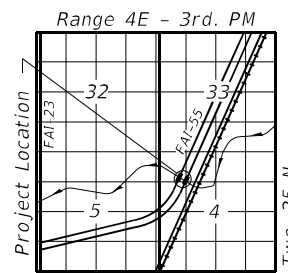

**LOCATION SKETCH**



Adam Bohnhoff  
Adam D. Bohnhoff  
Licensed Structural Engineer  
State of Illinois No. 081-007431  
Expires 11-30-2022  
Date 10-21-2021

MODEL: GPE  
FILE NAME: P:\Effingham\3454 - PTB 189 IDOT D5 VAVWork Order #6\Cadd\Sheet\173 & 174\0570D64\_0173\_0174\_Combined.dgn  
10/21/2021 2:58:29 PM



USER NAME =	DESIGNED - KAS	REVISIONS -
PLOT SCALE =	CHECKED - TJZ	REVISIONS -
PLOT DATE =	DRAWN - DWS	REVISIONS -
	CHECKED - KAS	REVISIONS -

**STATE OF ILLINOIS  
DEPARTMENT OF TRANSPORTATION**

**GENERAL PLAN AND ELEVATION  
S.N. 057-0173 (SB) & S.N. 057-0174 (NB)**

SHEET 1 OF 11 SHEETS

F.A.I. RTE.	SECTION	COUNTY	TOTAL SHEETS	SHEET NO.
55	(57-1,57-2)BDS	MCLEAN	88	47
CONTRACT NO. 70D64			ILLINOIS FED. AID PROJECT	



**TOTAL BILL OF MATERIAL SN 057-0173 & SN 057-0174**

Item	Unit	Total
Protective Coat	Sq. Yd.	1560
Floor Drains	Each	8
Polymer Modified Portland Cement Mortar	Sq. Ft.	562
Bridge Deck Grooving (Longitudinal)	Sq. Yd.	896
Bridge Deck Microsilica Concrete Overlay, 2 1/4"	Sq. Yd.	616
Bridge Deck Microsilica Concrete Overlay, 3 3/4"	Sq. Yd.	805
Bridge Deck Scarification, 2"	Sq. Yd.	616
Bridge Deck Scarification, 3 1/2"	Sq. Yd.	805
Structural Repair of Concrete (Depth = or < 5 inches)	Sq. Ft.	60
Deck Slab Repair (Full Depth, Type I)	Sq. Yd.	8
Concrete Removal	Cu. Yd.	10.3
Concrete Superstructure	Cu. Yd.	10.3
Diamond Grinding (Bridge Section)	Sq. Yd.	1288
Preformed Joint Sealer, 1"	Foot	160

**INDEX OF SHEETS**

- 1 General Plan and Elevation
- 2 General Data
- 3 Existing and Proposed Typical Cross Sections
- 4 Stage Construction Details (S.N. 057-0173)
- 5 Stage Construction Details (S.N. 057-0174)
- 6 Wearing Surface Plan
- 7 Floor Drain and Patching Details
- 8 Concrete Removal Details- North Abutment (S.N. 057-0173)
- 9 Concrete Superstructure Details - North Abutment (S.N. 057-0173)
- 10 Floor Drain Details
- 11 Substructure Repair Plan

**PROPOSED WORK**

1. Perform Bridge Deck Scarification on Bridge Deck, Approach Slabs, and PCC Connectors.
2. Perform Polymer Modified Portland Cement Mortar Repairs.
3. Concrete Removal at North Abutment SN 057-0173
4. Concrete Superstructure at North Abutment SN 057-0173
5. Place New Floor Drains.
6. Perform Full-Depth Patching and Approach Slab Repairs.
7. Perform Substructure Repairs.
8. Replace Joints at Approach Ends.
9. Place Microsilica Concrete Overlay on Bridge Deck and Approach Slabs.
10. Perform Diamond Grinding
11. Perform Longitudinal Deck Grooving
12. Apply Protective Coat

**GENERAL NOTES**

Plan dimensions and details relative to the existing structure have been taken from existing plans and are subject to nominal construction variations. It shall be the Contractor's responsibility to verify such dimensions and details in the field and make the necessary approved adjustments prior to construction or ordering of materials. Such variations shall not be cause for additional compensation for a change in the scope of work. However, the Contractor will be paid for the quantity actually furnished at the unit price for the work.

Reinforcement bars designated (E) shall be epoxy coated.

Prior to pouring the new concrete deck, all heavy or loose rust, loose mill scale, and other loose or potentially detrimental foreign material shall be removed from the surfaces in contact with concrete. Tightly adhered paint may remain unless otherwise noted. Removal shall be accomplished by methods that will not damage the steel and the cost will be included in the pay item covering removal of the existing concrete.

Joint openings shall be adjusted according to Article 520.04 of the Std. Specs. when the deck is poured at an ambient temperature other than 50°F.

Up to 1/4" may be ground off the bridge deck and bridge approach slabs through Diamond Grinding.

Expansion joints shall be fabricated and installed according to the manufacturer's recommendations and as approved by the Engineer. Expansion joints shall be fabricated to conform to the existing cross slopes of the bridge.

Protective Coat shall be applied from end to end of approaches to entire deck surface and along the vertical faces of the parapets.

Synthetic fibers shall be included in the bridge deck concrete overlay specified. See Special Provisions.

MODEL: General Notes  
FILE NAME: P:\Effingham\3454 - PTB 189 IDOT D5 V-V\Work Order #6\Cadd\Sheet\173 & 174\0570D64\_0173\_0174\_Combined.dgn



**CIVIL DESIGN, INC.**  
WBE / DBE  
EFFINGHAM, IL  
LICENSE # 184.003222

USER NAME =	DESIGNED - KAS	REVISED -
	CHECKED - TJZ	REVISED -
PLOT SCALE =	DRAWN - DWS	REVISED -
PLOT DATE =	CHECKED - KAS	REVISED -

**STATE OF ILLINOIS  
DEPARTMENT OF TRANSPORTATION**

**GENERAL DATA  
S.N. 057-0173 (SB) & S.N. 057-0174 (NB)**

SHEET 2 OF 11 SHEETS

F.A.I. RTE.	SECTION	COUNTY	TOTAL SHEETS	SHEET NO.
55	(57-1,57-2)BDS	MCLEAN	88	48
			CONTRACT NO. 70D64	
		ILLINOIS	FED. AID PROJECT	

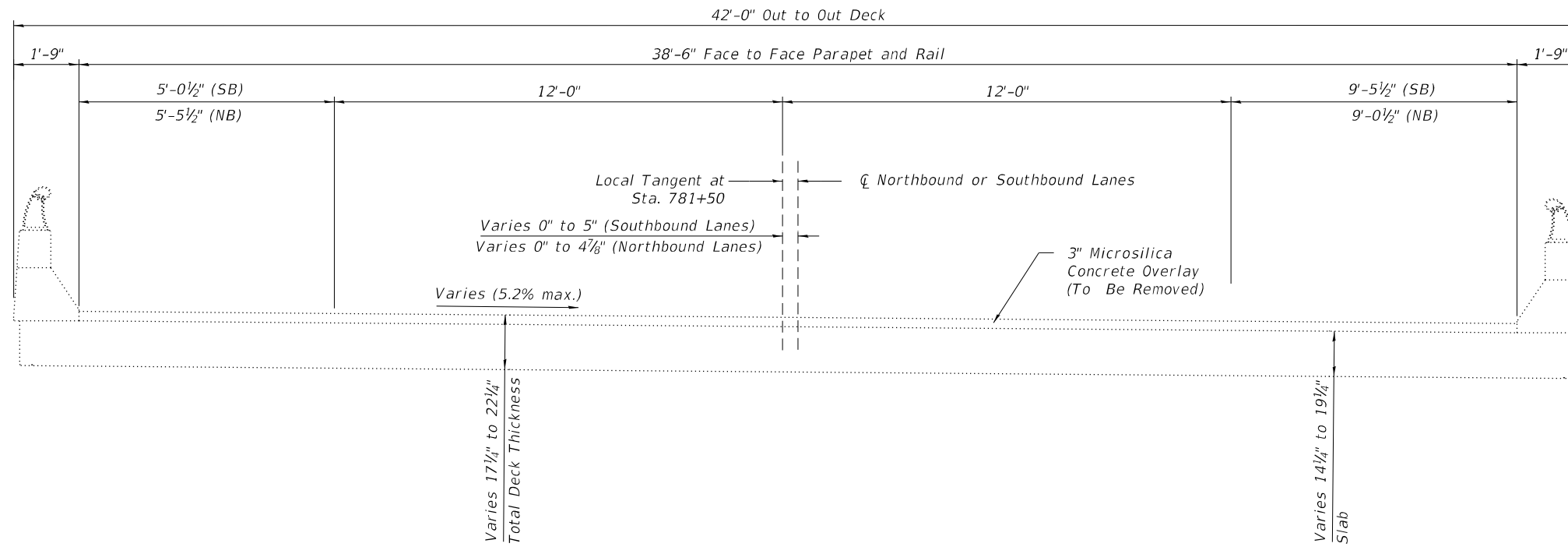

**EXISTING CROSS SECTION**  
 S.N. 057-0173 (SB) Looking South Shown  
 S.N. 057-0174 (NB) Looking North Similar but Opposite Superelevation

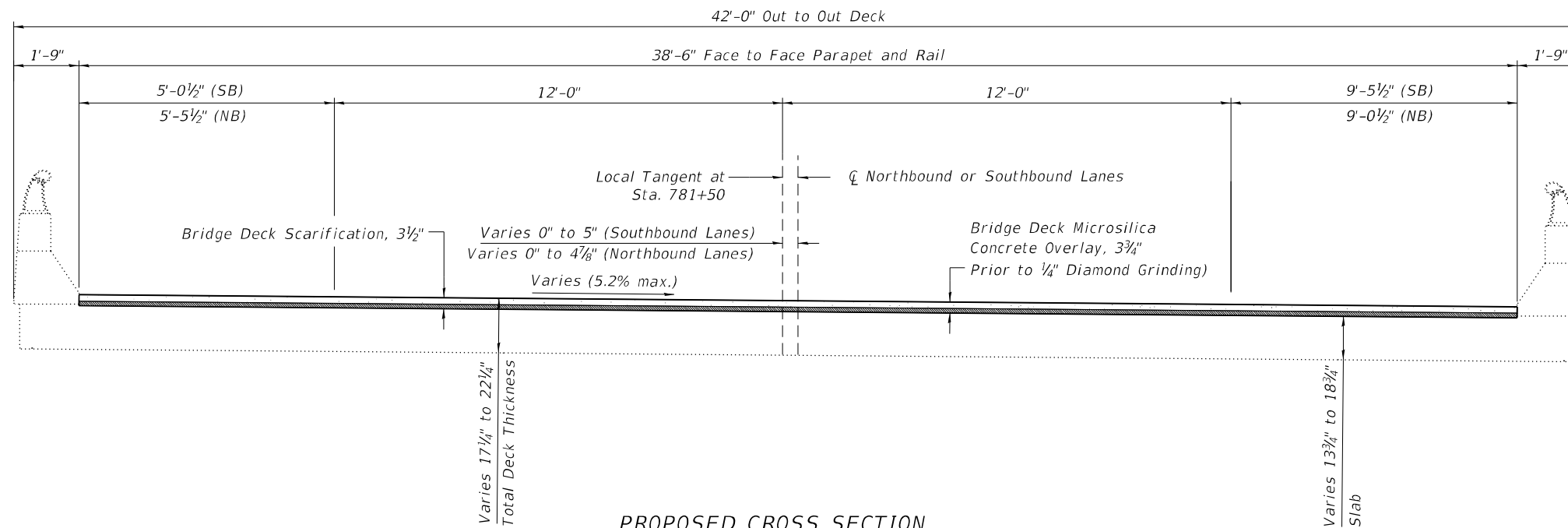

**PROPOSED CROSS SECTION**  
 S.N. 057-0173 (SB) Looking South Shown  
 S.N. 057-0174 (NB) Looking North Similar but Opposite Superelevation

MODEL: Cross Section  
 FILE NAME: P:\Effingham\3454 - PTB\_189\_IDOT D5 V-V\Work Order #6\Cadd\Sheet\173 & 174\0570D64\_0173\_0174\_Combined.dgn  
 11/29/2021 12:42:48 PM



**CIVIL DESIGN, INC.**  
 WBE / DBE  
 EFFINGHAM, IL  
 LICENSE # 184.003222

USER NAME =	DESIGNED - KAS	REVISED -
	CHECKED - TJZ	REVISED -
PLOT SCALE =	DRAWN - DWS	REVISED -
PLOT DATE =	CHECKED - KAS	REVISED -

**STATE OF ILLINOIS  
 DEPARTMENT OF TRANSPORTATION**

**EXISTING AND PROPOSED TYPICAL CROSS SECTIONS  
 S.N. 057-0173 (SB) & S.N. 057-0174 (NB)**

SHEET 3 OF 11 SHEETS

F.A.I. RTE.	SECTION	COUNTY	TOTAL SHEETS	SHEET NO.
55	(57-1,57-2)BDS	MCLEAN	88	49
			CONTRACT NO. 70D64	
		ILLINOIS FED. AID PROJECT		

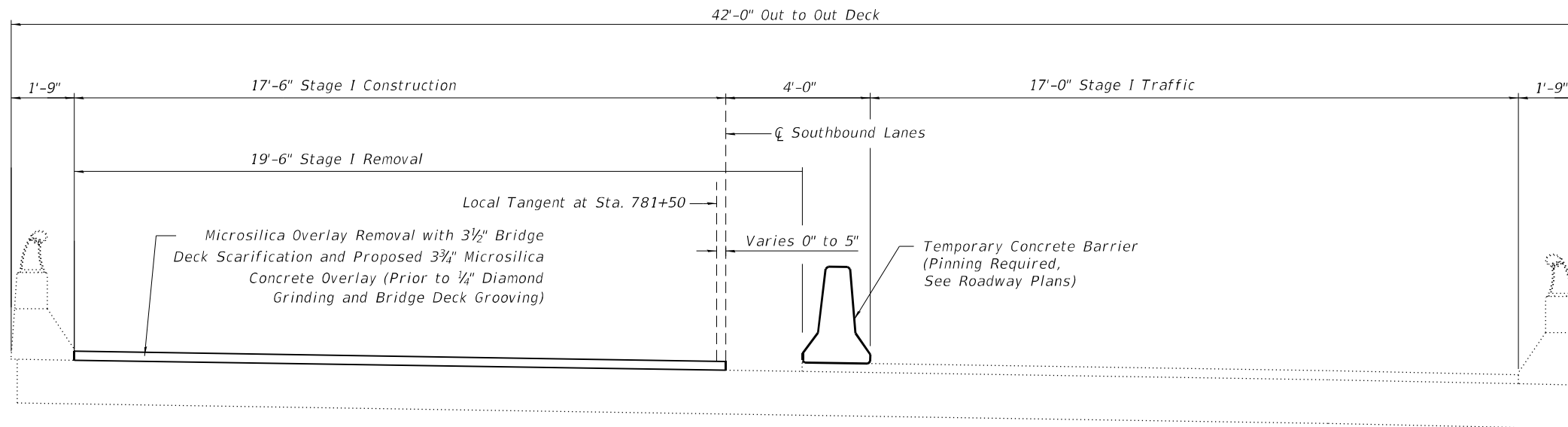

**STAGE I CONSTRUCTION DETAIL**  
(Looking South)

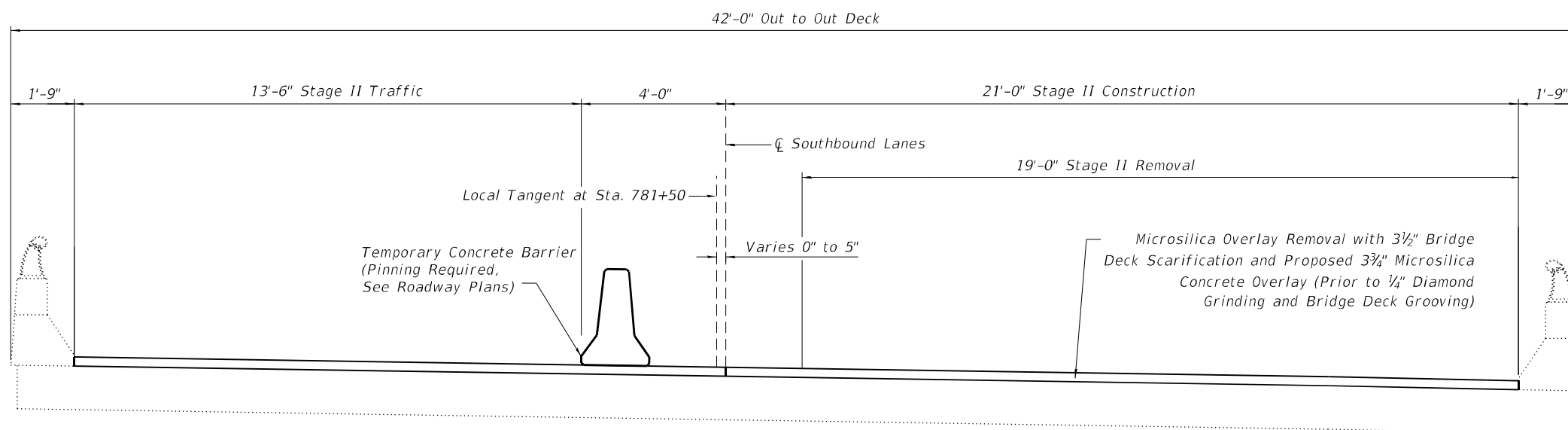

**STAGE II CONSTRUCTION DETAIL**  
(Looking South)

MODEL: Stage Construction 0173  
FILE NAME: P:\Effingham\3454 - PTB 189 IDOT D5 V-V\Work Order #6\Cadd\Sheet\173 & 174\0570D64\_0173\_0174\_Combined.dgn



**CIVIL DESIGN, INC.**  
WBE / DBE  
EFFINGHAM, IL  
LICENSE # 184.003222

USER NAME =	DESIGNED - KAS	REVISED -
	CHECKED - TJZ	REVISED -
PLOT SCALE =	DRAWN - DWS	REVISED -
PLOT DATE =	CHECKED - KAS	REVISED -

**STATE OF ILLINOIS**  
**DEPARTMENT OF TRANSPORTATION**

**STAGE CONSTRUCTION DETAILS**  
**S.N. 057-0173 (SB)**

SHEET 4 OF 11 SHEETS

F.A.I. RTE.	SECTION	COUNTY	TOTAL SHEETS	SHEET NO.
55	(57-1,57-2)BDS	MCLEAN	88	50
CONTRACT NO. 70D64				

ILLINOIS FED. AID PROJECT

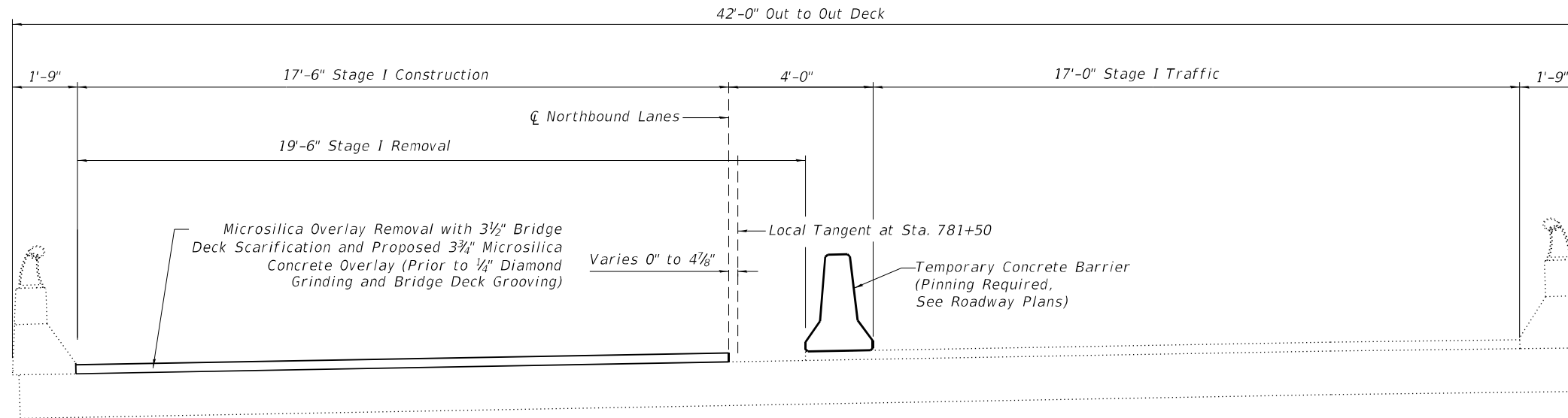

**STAGE I CONSTRUCTION DETAIL**  
(Looking North)

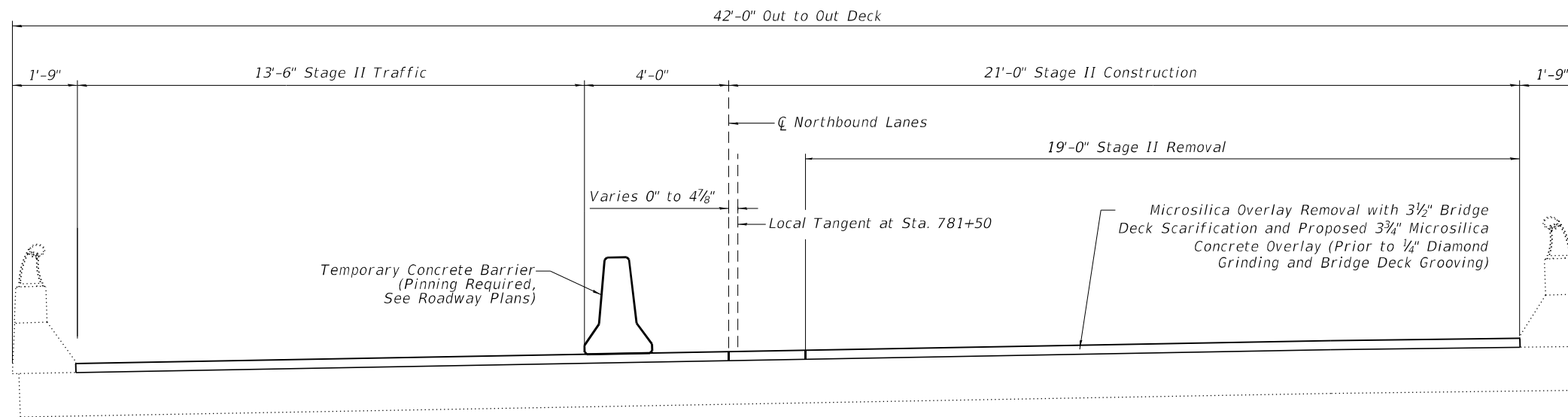

**STAGE II CONSTRUCTION DETAIL**  
(Looking North)

MODEL: Stage Construction 0174  
FILE NAME: P:\Effingham\3454 - PTB 189 IDOT D5 V-V\Work Order #6\Cadd\Sheet\173 & 174\0570D64\_0173\_0174\_Combined.dgn



CIVIL DESIGN, INC.  
WBE / DBE  
EFFINGHAM, IL  
LICENSE # 184.003222

USER NAME =	DESIGNED - KAS	REVISED -
	CHECKED - TJZ	REVISED -
PLOT SCALE =	DRAWN - DWS	REVISED -
PLOT DATE =	CHECKED - KAS	REVISED -

STATE OF ILLINOIS  
DEPARTMENT OF TRANSPORTATION

STAGE CONSTRUCTION DETAILS  
S.N. 057-0174 (NB)

SHEET 5 OF 11 SHEETS

F.A.I. RTE.	SECTION	COUNTY	TOTAL SHEETS	SHEET NO.
55	(57-1,57-2)BDS	MCLEAN	88	51
CONTRACT NO. 70D64				
ILLINOIS FED. AID PROJECT				

☐ Southbound Lanes  
at Local Tangent  
Sta. 781+50  
(S.N. 057-0173)

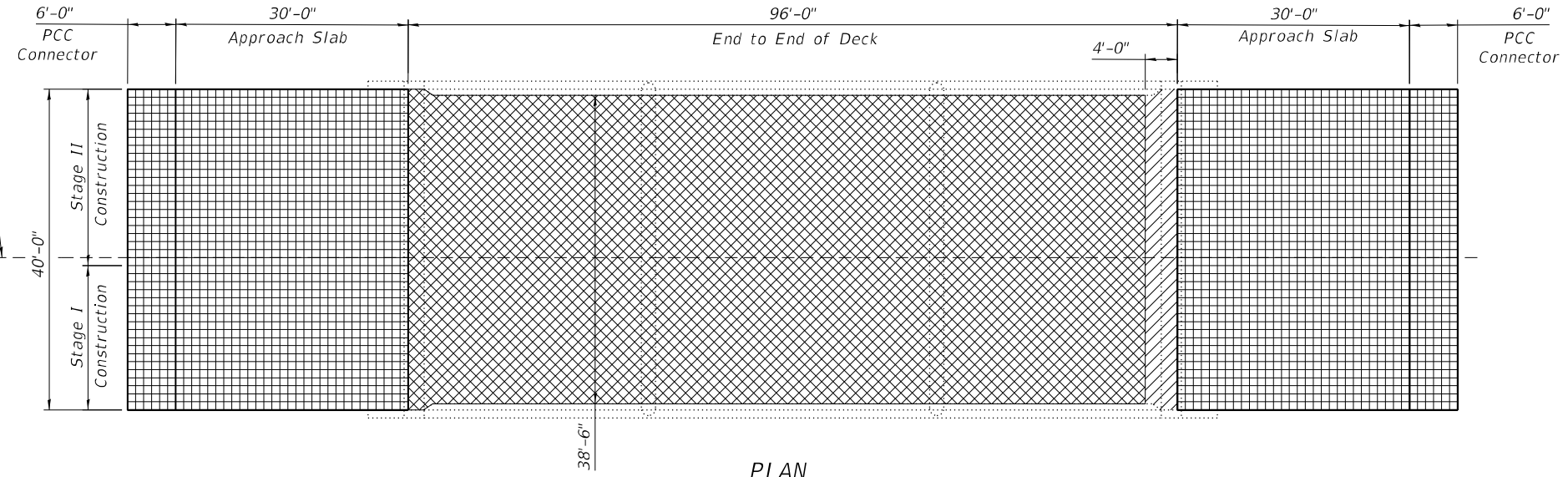

**PLAN**  
(S.N. 057-0173)

☐ Northbound Lanes  
at Local Tangent  
Sta. 781+50  
(S.N. 057-0174)

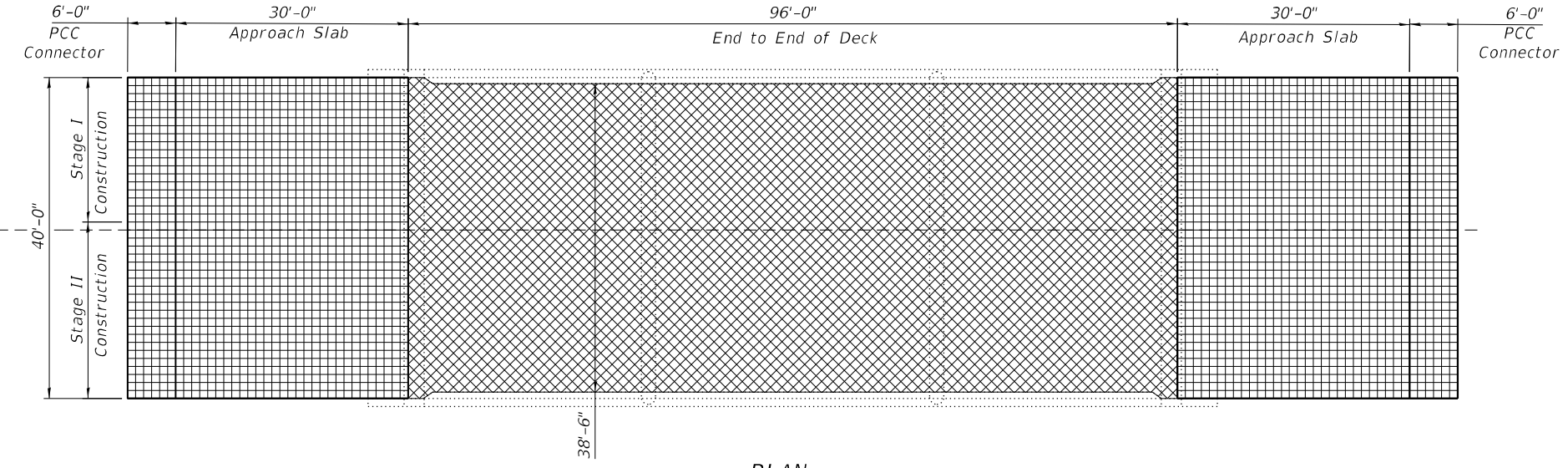

**PLAN**  
(S.N. 057-0174)

**BILL OF MATERIAL**  
(Deck & Approach)

Structure	Item	Unit	Total
057-0173	Bridge Deck Microsilica Concrete Overlay, 3 3/4"	Sq. Yd.	394
	Bridge Deck Microsilica Concrete Overlay, 2 1/4"	Sq. Yd.	308
	Bridge Deck Scarification, 3 1/2"	Sq. Yd.	394
	Bridge Deck Scarification, 2"	Sq. Yd.	308
	Bridge Deck Grooving (Longitudinal)	Sq. Yd.	448
057-0174	Diamond Grinding (Bridge Section)	Sq. Yd.	644
	Bridge Deck Microsilica Concrete Overlay, 3 3/4"	Sq. Yd.	411
	Bridge Deck Microsilica Concrete Overlay, 2 1/4"	Sq. Yd.	308
	Bridge Deck Scarification, 3 1/2"	Sq. Yd.	411
	Bridge Deck Scarification, 2"	Sq. Yd.	308
	Bridge Deck Grooving (Longitudinal)	Sq. Yd.	448
	Diamond Grinding (Bridge Section)	Sq. Yd.	644

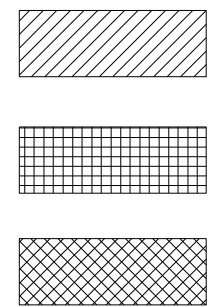

*Diagonal Hatching:* Diamond Grinding, 1/4" and Bridge Deck Grooving (Longitudinal)  
(Area of Full Depth Removal at Deck End North Abutment SN 057-0173)

*Grid Hatching:* Bridge Deck Scarification, 2", Bridge Deck Microsilica Concrete Overlay, 2 1/4",  
Diamond Grinding, 1/4" and Bridge Deck Grooving (Longitudinal)

*Cross-hatch Hatching:* Bridge Deck Scarification, 3 1/2", Bridge Microsilica Concrete Overlay, 3 3/4",  
Diamond Grinding, 1/4" and Bridge Deck Grooving (Longitudinal)

1/4" x 3/4" Sawed Joint with Bridge Relief Joint Sealer (Full Width),  
See Spec. Book Section 588

Microsilica Concrete Overlay

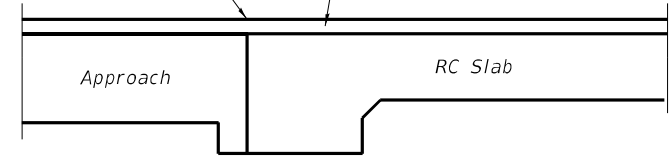

**TYPICAL JOINT DETAIL AT ALL DECK ENDS**

Note:  
Cost of Sawed Joint and Bridge Relief Joint Sealer  
included with Bridge Deck Microsilica Concrete Overlay, 2 1/4"

MODEL: Wearing Surface  
FILE NAME: P:\Effingham\3454 - PTB - 189 IDOT D5 V-V\Work Order #6\Cadd\Sheet\173 & 174\0570D64\_0173\_0174\_Combined.dgn



CIVIL DESIGN, INC.  
WBE / DBE  
EFFINGHAM, IL  
LICENSE # 184.003222

USER NAME =	DESIGNED - KAS	REVISED -
	CHECKED - TJZ	REVISED -
PLOT SCALE =	DRAWN - DWS	REVISED -
PLOT DATE =	CHECKED - KAS	REVISED -

STATE OF ILLINOIS  
DEPARTMENT OF TRANSPORTATION

WEARING SURFACE PLAN  
S.N. 057-0173 (SB) & S.N. 057-0174 (NB)

SHEET 6 OF 11 SHEETS

F.A.I. RTE.	SECTION	COUNTY	TOTAL SHEETS	SHEET NO.
55	(57-1.57-2)BDS	MCLEAN	88	52
			CONTRACT NO. 70D64	

ILLINOIS FED. AID PROJECT

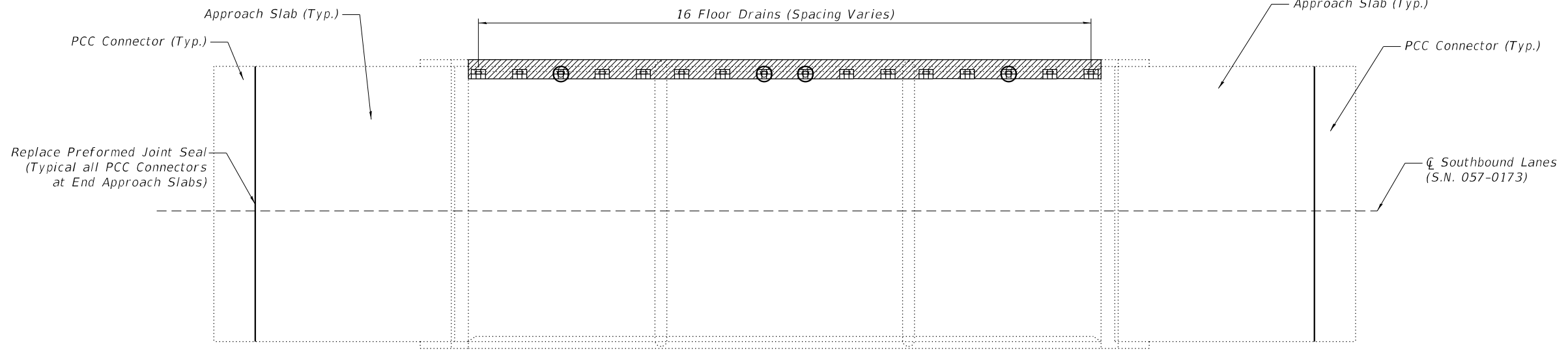

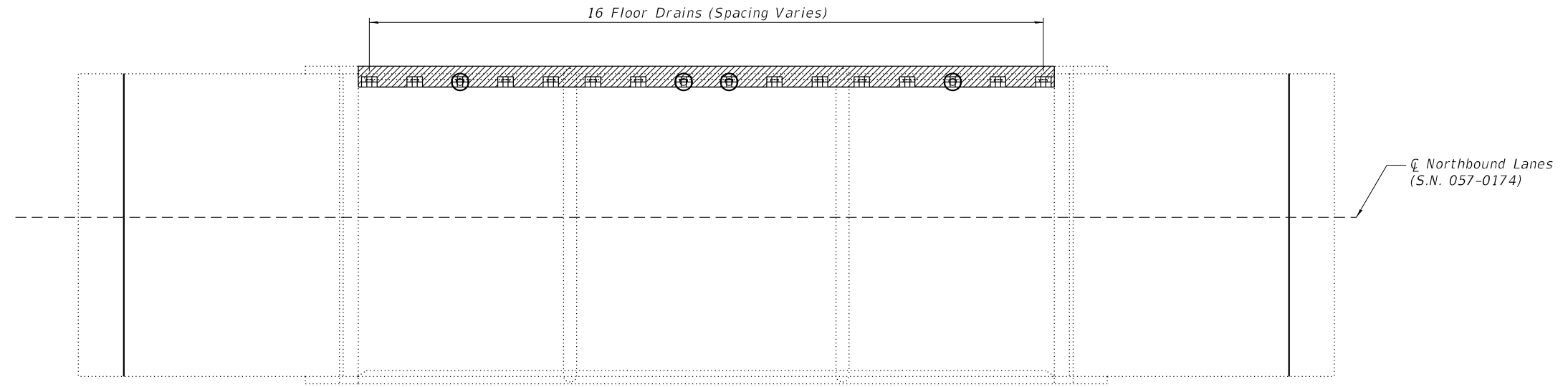

PLAN



PLAN

**LEGEND**

-  Proposed floor drain location
-  Deck Slab Repair (Full Depth, Type I) at all Drain Locations. All repair areas are 2'-0" x 1'-1", unless otherwise noted.
-  Polymer Modified Portland Cement Mortar

**NOTES:**

Patch sizes shown represent conditions at the time the plans were completed.

The actual sizes and locations of patching shall be determined by the Resident Engineer after removal of the wearing surface, before deck patching operations begin. The Engineer shall show the actual locations of the deck repairs on As-Built plans.

The existing drains and extensions shall be removed. Cost included with Deck Slab Repair (Full Depth, Type I).

**BILL OF MATERIAL**

Structure	Item	Unit	Total
057-0173	Deck Slab Repair (Full Depth, Type I)	Sq. Yd.	4
057-0173	Polymer Modified Portland Cement Mortar	Sq. Ft.	281
057-0173	Preformed Joint Seal, 2 3/4"	Foot	80
057-0174	Deck Slab Repair (Full Depth, Type I)	Sq. Yd.	4
057-0174	Polymer Modified Portland Cement Mortar	Sq. Ft.	281
057-0174	Preformed Joint Seal, 2 3/4"	Foot	80

MODEL: Patching  
FILE NAME: P:\Effingham\3454 - PTB\_189\_IDOT\_D5-V\Work Order #6\Cadd\Sheet\173 & 174\0570D64\_0173\_0174\_Combined.dgn



CIVIL DESIGN, INC.  
WBE / DBE  
EFFINGHAM, IL  
LICENSE # 184.003222

USER NAME =	DESIGNED - KAS	REVISED -
	CHECKED - TJZ	REVISED -
PLOT SCALE =	DRAWN - DWS	REVISED -
PLOT DATE =	CHECKED - KAS	REVISED -

STATE OF ILLINOIS  
DEPARTMENT OF TRANSPORTATION

FLOOR DRAIN AND PATCHING DETAILS  
S.N. 057-0173 (SB) & S.N. 057-0174 (NB)

SHEET 7 OF 11 SHEETS

F.A.I. RTE.	SECTION	COUNTY	TOTAL SHEETS	SHEET NO.
55	(57-1,57-2)BDS	MCLEAN	88	53
			CONTRACT NO. 70D64	

ILLINOIS FED. AID PROJECT

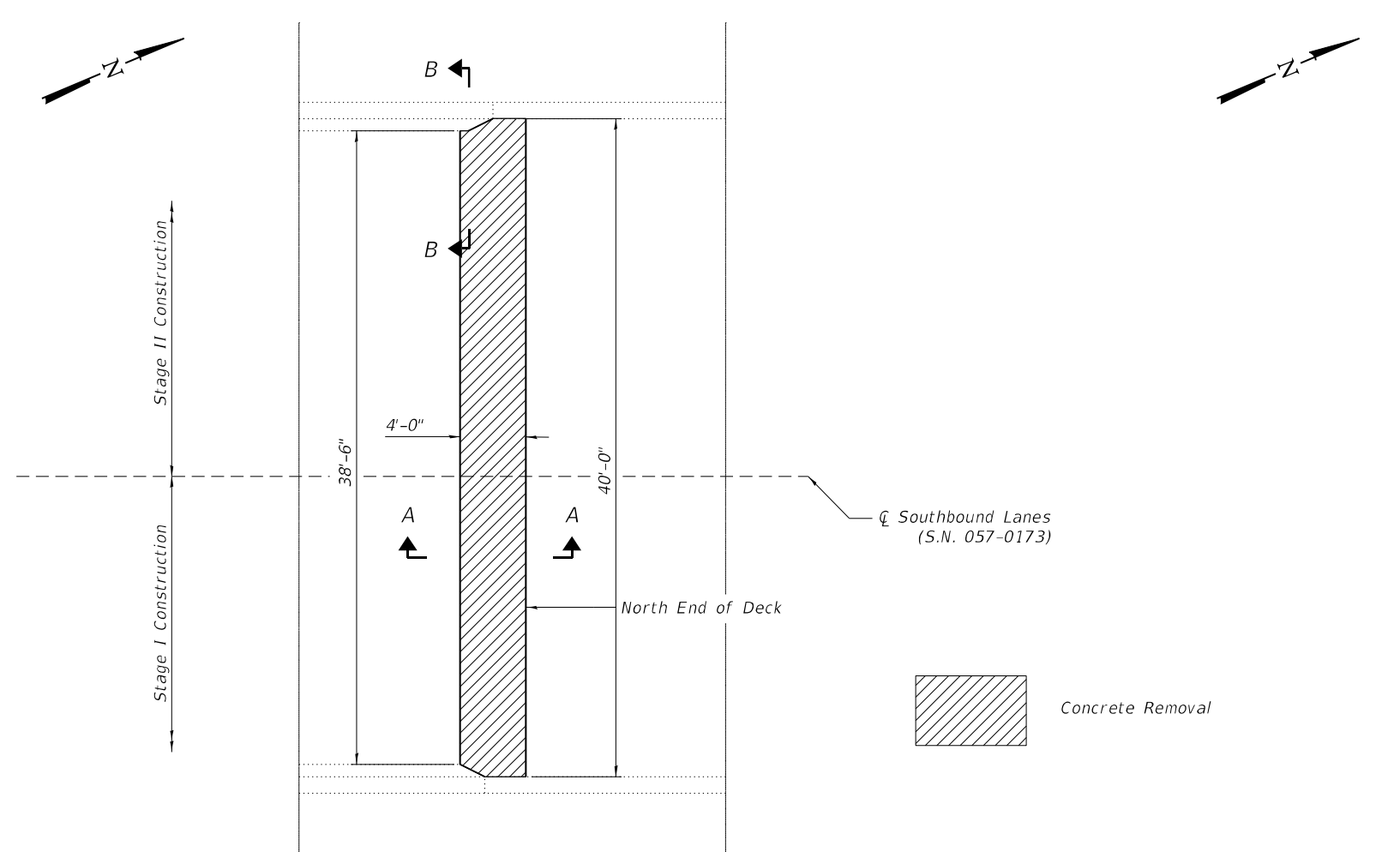

PLAN

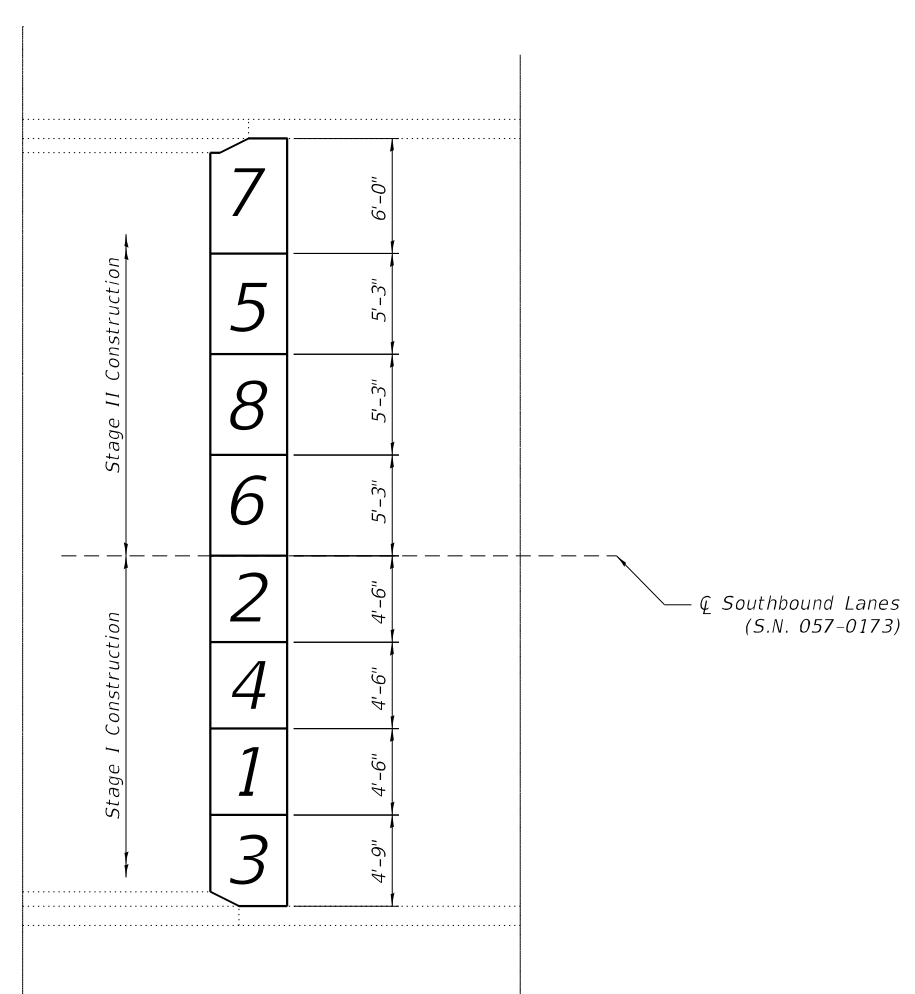

DECK REPAIR SEQUENCE

Remove and replace sections in the following order:  
 1 & 2 before 3 & 4  
 5 & 6 before 7 & 8

NOTES:

Existing reinforcing bars extending into the removal area shall be cleaned, straightened and incorporated into the New Construction. Any reinforcing bars that are damaged during Concrete Removal shall be replaced with an approved bar splicer or anchorage system. Cost included with Concrete Removal.

Removal of deck must be sequenced so that removals are staggered and adjacent sections are not removed at the same time.

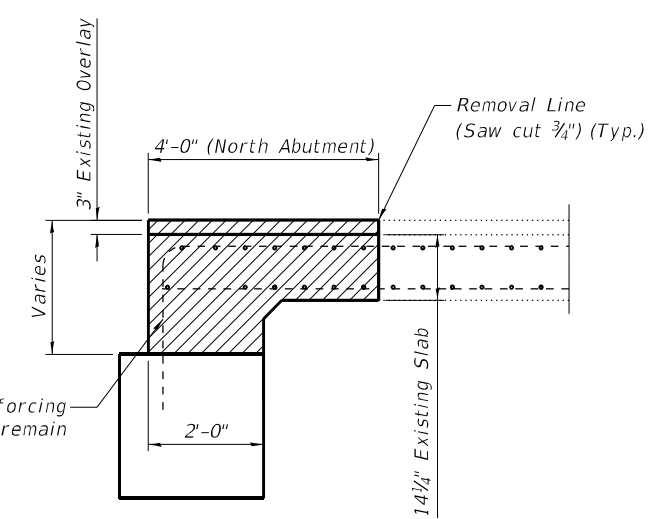

SECTION A-A

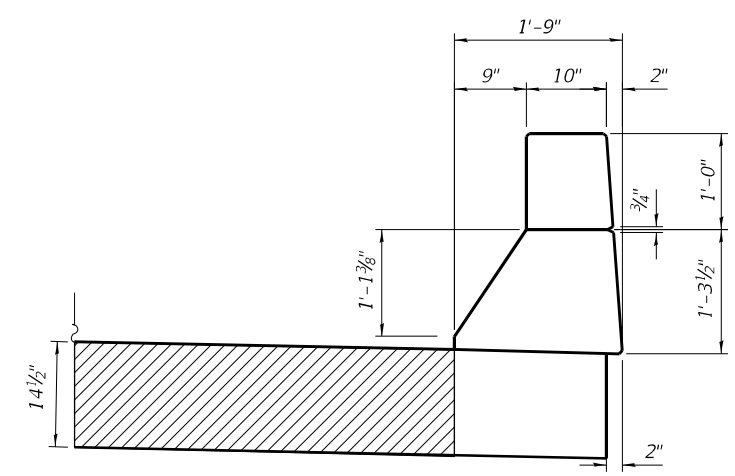

SECTION B-B

BILL OF MATERIAL

Structure	Item	Unit	Total
057-0173	Concrete Removal	Cu. Yd.	10.3

MODEL: Concrete Removal  
 FILE NAME: P:\Effingham\3454 - PTB\_189\_IDOT D5 V-VI\Work\_Order\_#6\Cadd\Sheet\173 & 174\0570D64\_0173\_0174\_Combined.dgn



CIVIL DESIGN, INC.  
 WBE / DBE  
 EFFINGHAM, IL  
 LICENSE # 184.003222

USER NAME =	DESIGNED - KAS	REVISED -
	CHECKED - TJZ	REVISED -
PLOT SCALE =	DRAWN - DWS	REVISED -
PLOT DATE =	CHECKED - KAS	REVISED -

STATE OF ILLINOIS  
 DEPARTMENT OF TRANSPORTATION

CONCRETE REMOVAL  
 S.N. 057-0173 (SB)

SHEET 8 OF 11 SHEETS

F.A.I. RTE.	SECTION	COUNTY	TOTAL SHEETS	SHEET NO.
55	(57-1,57-2)BDS	MCLEAN	88	54
			CONTRACT NO. 70D64	
ILLINOIS FED. AID PROJECT				

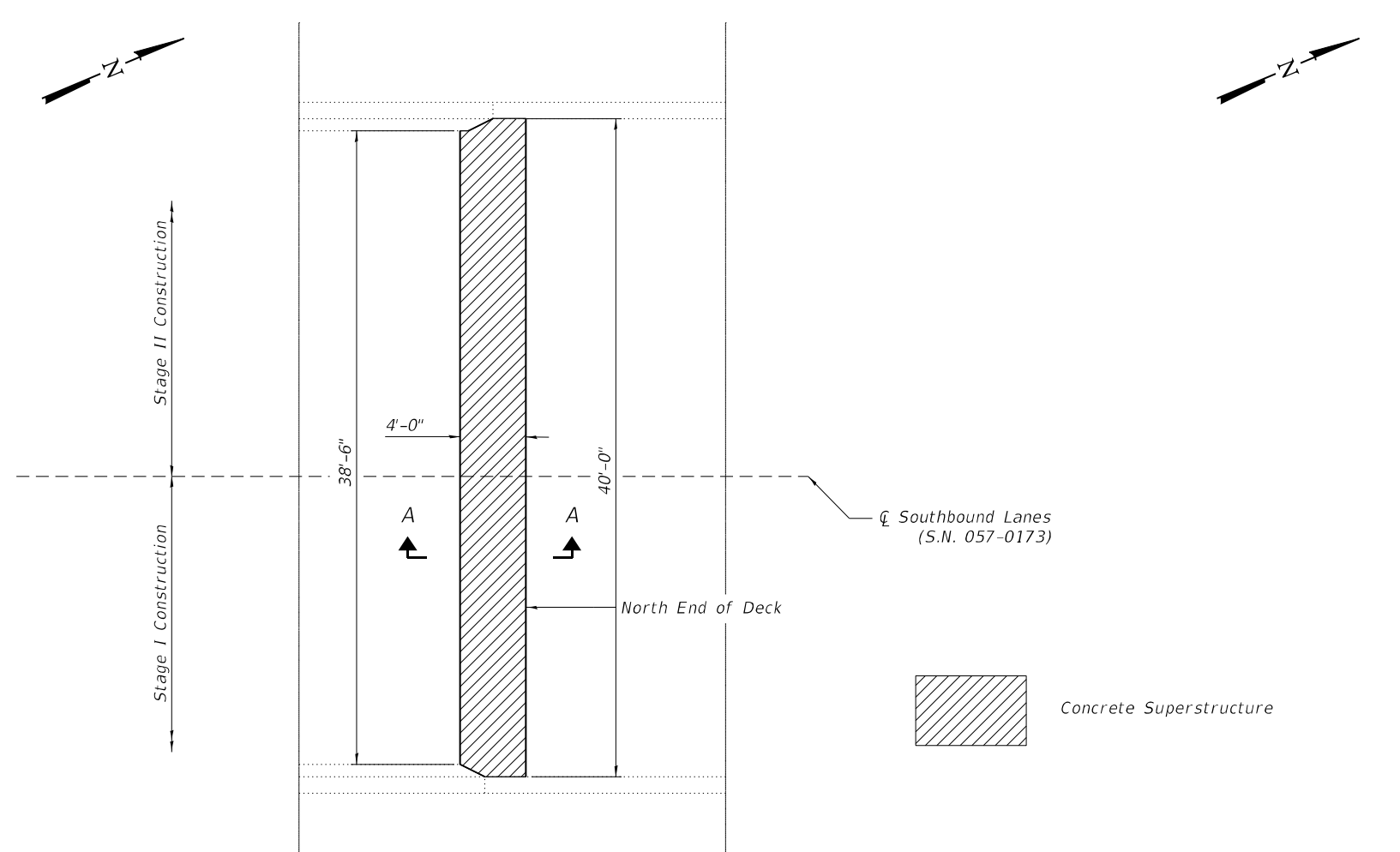

**PLAN**

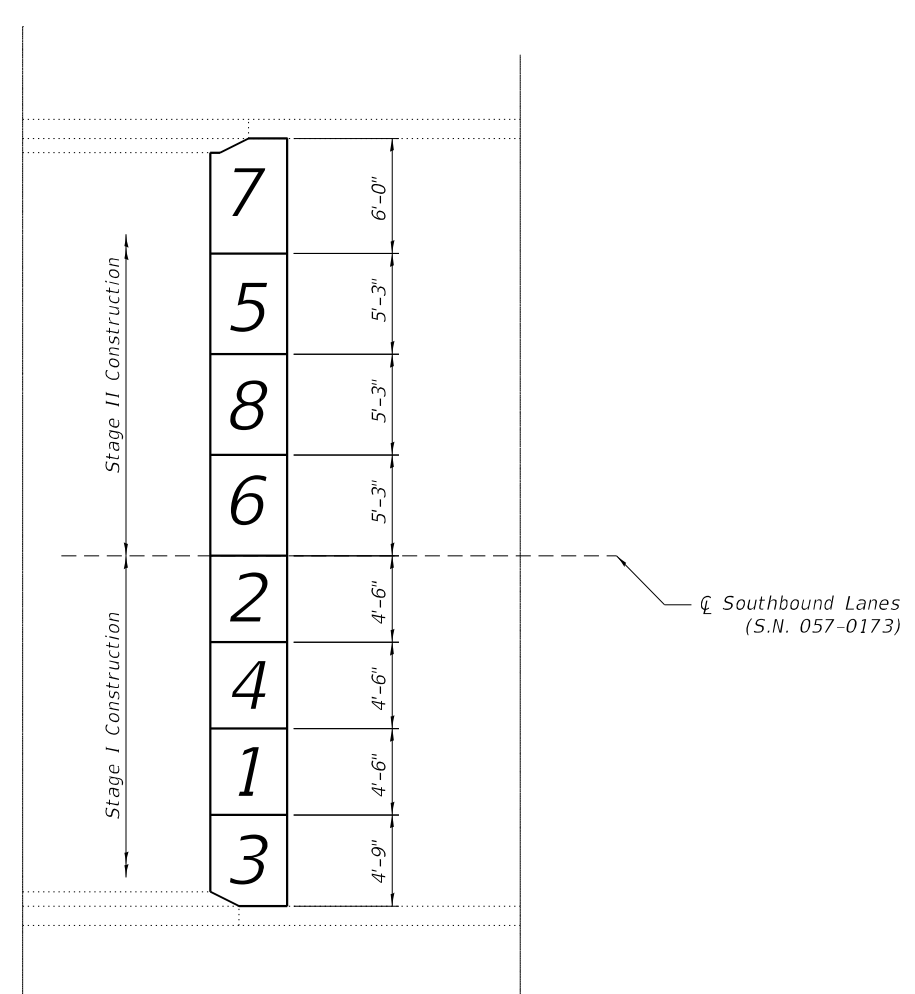

**DECK REPAIR SEQUENCE**

Remove and replace sections in the following order:  
 1 & 2 before 3 & 4  
 5 & 6 before 7 & 8

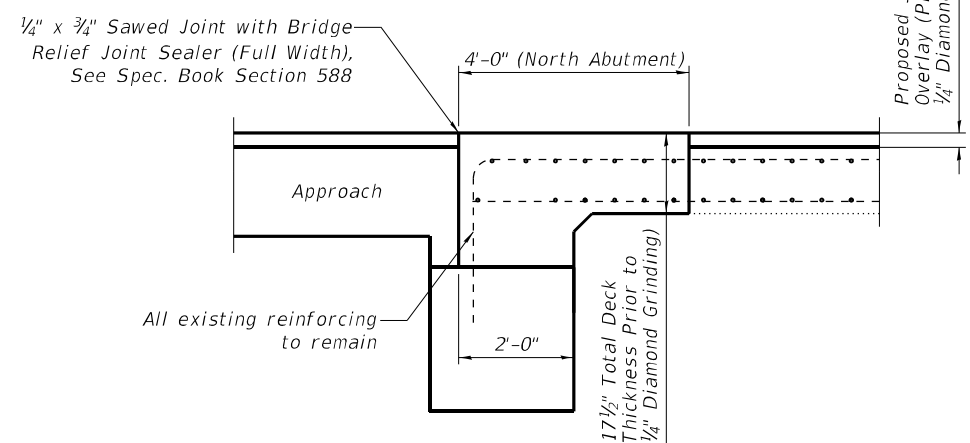

**SECTION A-A**

**NOTES:**

Existing reinforcement bars extending into the removal area shall be cleaned, straightened and incorporated into the New Construction. Any reinforcement bars that are damaged during Concrete Removal shall be replaced with an approved bar splicer or anchorage system. Cost included with Concrete Removal.

Removal of deck must be sequenced so that removals are staggered and adjacent sections are not removed at the same time.

Cost of Sawed Joint and Bridge Relief Joint Sealer included with Bridge Deck Microsilica Concrete Overlay, 2 1/4".

**BILL OF MATERIAL**

Structure	Item	Unit	Total
057-0173	Concrete Superstructure	Cu. Yd.	10.3

MODEL: Concrete Superstructure  
 FILE NAME: P:\Effingham\3454 - PTB\_189\_IDOT D5 V-VI\Work\_Order\_#6\Cadd\Sheet\173 & 174\0570D64\_0173\_0174\_Combined.dgn  
 11/29/2021 12:44:17 PM

**CIVIL DESIGN, INC.**  
 WBE / DBE  
 EFFINGHAM, IL  
 LICENSE # 184.003222

USER NAME =	DESIGNED - KAS	REVISED -
PLOT SCALE =	CHECKED - TJZ	REVISED -
PLOT DATE =	DRAWN - DWS	REVISED -
	CHECKED - KAS	REVISED -

**STATE OF ILLINOIS**  
**DEPARTMENT OF TRANSPORTATION**

**CONCRETE SUPERSTRUCTURE**  
**S.N. 057-0173 (SB)**  
 SHEET 9 OF 11 SHEETS

F.A.I. RTE. =	SECTION =	COUNTY =	TOTAL SHEETS =	SHEET NO. =
55	(57-1,57-2)BDS	MCLEAN	88	55
			CONTRACT NO. 70D64	
ILLINOIS FED. AID PROJECT				



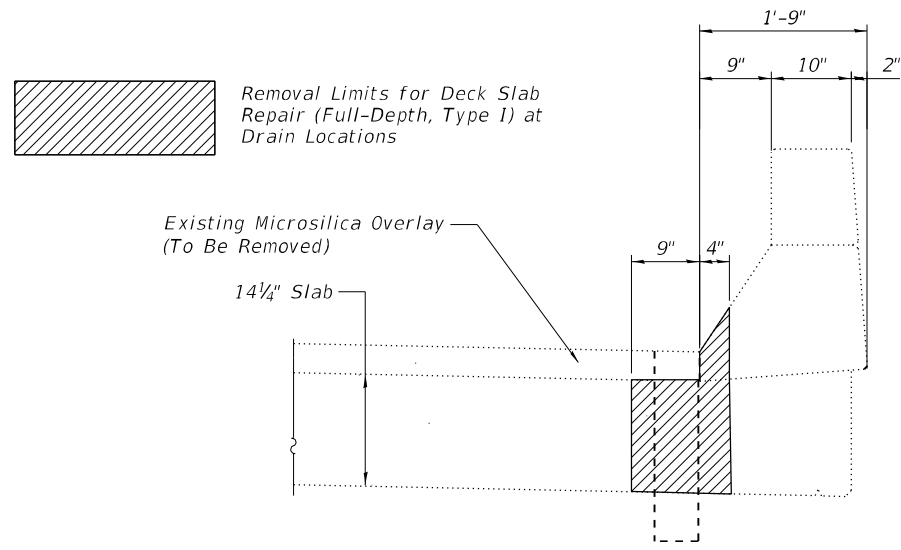

Removal Limits for Deck Slab Repair (Full-Depth, Type 1) at Drain Locations

Existing Microsilica Overlay (To Be Removed)

1 1/4" Slab

TYPICAL REMOVAL LIMITS

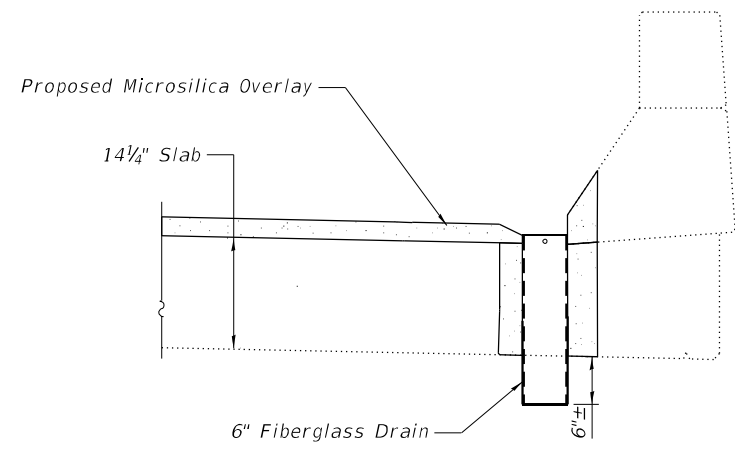

Proposed Microsilica Overlay

1 1/4" Slab

6" Fiberglass Drain

TYPICAL DRAIN REPLACEMENT

Drill air vent holes through deck at locations specified by Engineer. Holes to be filled in with Polymer Modified Portland Cement Mortar. Cost incidental to Polymer Modified Portland Cement Mortar.

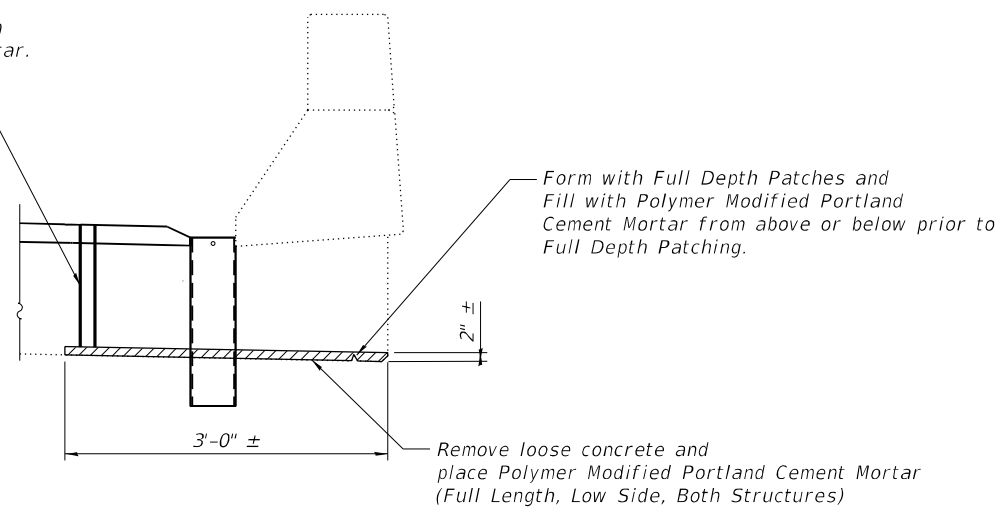

Form with Full Depth Patches and Fill with Polymer Modified Portland Cement Mortar from above or below prior to Full Depth Patching.

Remove loose concrete and place Polymer Modified Portland Cement Mortar (Full Length, Low Side, Both Structures)

TYPICAL MORTAR REPAIR

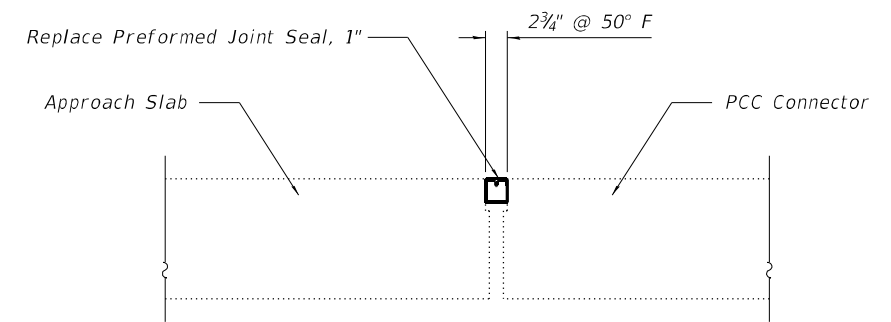

Replace Preformed Joint Seal, 1"

2 3/4" @ 50° F

Approach Slab

PCC Connector

PREFORMED JOINT REPLACEMENT DETAIL

S.N. 057-0173 North & South Approach  
S.N. 057-0174 North & South Approach

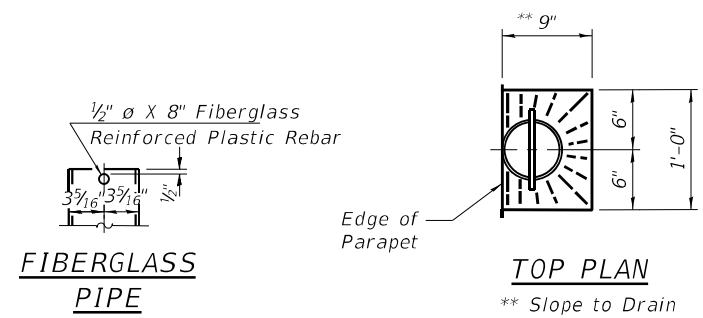

FIBERGLASS PIPE

TOP PLAN  
\*\* Slope to Drain

NOTES:

All dimensions shall be field verified by the Contractor prior to ordering of materials.

Extreme care shall be taken when removing concrete and placing new floor drains around existing slab reinforcing. Some minor deformation of the new floor drains may be necessary in order to facilitate placement around existing reinforcement.

Fiberglass pipe shall conform to ASTM 02296, with short-time rupture strength hoop tensile stress of 30,000 psi minimum.

The exterior surfaces of the floor drains shall be painted according to Article 506 with the finish coat as specified.

The exterior surfaces of the drains shall be cleaned according to the Society of Protective Coating Spec. SSPC-SPI prior to painting.

BILL OF MATERIAL

Structure	Item	Unit	Total
057-0173	Floor Drains	Each	4
057-0174	Floor Drains	Each	4

Cost of removal of existing drains and extensions is included in Deck Slab Repair (Full Depth, Type 1).

MODEL: Floor Drain Details  
FILE NAME: P:\Effingham\3454 - PTB\_189.IDOT.D5.V-VI\Work\_Order\_#6\Cadd\Sheet\173 & 174\0570D64\_0173\_0174\_Combined.dgn  
11/29/2021 12:45:11 PM



CIVIL DESIGN, INC.  
WBE / DBE  
EFFINGHAM, IL  
LICENSE #184.003222

USER NAME =	DESIGNED - KAS	REVISED -
PLOT SCALE =	CHECKED - TJZ	REVISED -
PLOT DATE =	DRAWN - DWS	REVISED -
	CHECKED - KAS	REVISED -

STATE OF ILLINOIS  
DEPARTMENT OF TRANSPORTATION

FLOOR DRAIN DETAILS  
S.N. 057-0173 (SB) & S.N. 057-0174 (NB)

SHEET 10 OF 11 SHEETS

F.A.I. RTE.	SECTION	COUNTY	TOTAL SHEETS	SHEET NO.
55	(57-1,57-2)BDS	MCLEAN	88	56
			CONTRACT NO. 70D64	
ILLINOIS FED. AID PROJECT				

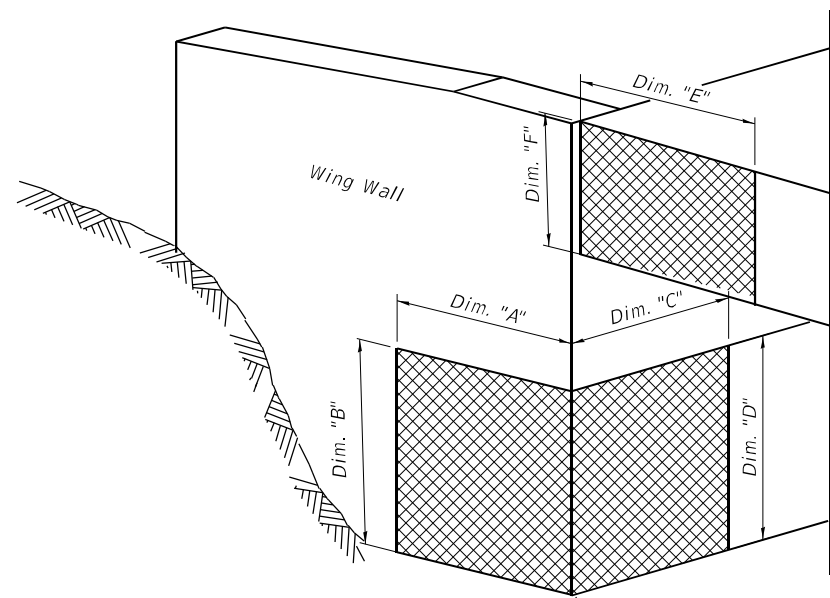

ISOMETRIC VIEW AT ABUTMENT CORNER

S.N. 057-0173  
TABLE FOR STRUCTURAL REPAIR OF CONCRETE

ABUTMENT CORNER	Repair Area Dimensions						Repair Area Sq. Ft.
	Wingwall		Backwall		Slab Edge		
	A	B	C	D	E	F	
Northeast	3	4	2	3	1	1	19
Southeast	-	-	-	-	-	-	-
Northwest	-	-	2	2	3	1	7
Southwest	2	2	-	-	-	-	4

S.N. 057-0174  
TABLE FOR STRUCTURAL REPAIR OF CONCRETE

ABUTMENT CORNER	Repair Area Dimensions						Repair Area Sq. Ft.
	Wingwall		Backwall		Slab Edge		
	A	B	C	D	E	F	
Northeast	2	3	-	-	1	1	7
Southeast	-	-	-	-	3	1	3
Northwest	3	3	1	1	2	2	14
Southwest	1	3	-	-	3	1	6

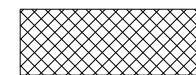

Structural Repair of Concrete  
Depth equal to or Less than 5"

NOTE:

See Special Provision for Structural Repair of Concrete.

BILL OF MATERIAL

Structure	Item	Unit	Total
057-0173	Structural Repair of Concrete, Depth Equal to or Less than 5"	Sq. Ft.	30
057-0174	Structural Repair of Concrete, Depth Equal to or less than 5"	Sq. Ft.	30

MODEL: Abutment Repairs  
FILE NAME: P:\Effingham\3454 - PTB 189 IDOT D5 V-V\Work Order #6\Cadd\Sheet\173 & 174\0570D64\_0173\_0174\_Combined.dgn  
10/21/2021 2:58:42 PM



CIVIL DESIGN, INC.  
WBE / DBE  
EFFINGHAM, IL  
LICENSE # 184.003222

USER NAME =	DESIGNED - KAS	REVISED -
	CHECKED - TJZ	REVISED -
PLOT SCALE =	DRAWN - DWS	REVISED -
PLOT DATE =	CHECKED - KAS	REVISED -

STATE OF ILLINOIS  
DEPARTMENT OF TRANSPORTATION

SUBSTRUCTURE REPAIR PLAN  
S.N. 057-0173 (SB) & S.N. 057-0174 (NB)

SHEET 11 OF 11 SHEETS

F.A.I. RTE.	SECTION	COUNTY	TOTAL SHEETS	SHEET NO.
55	(57-1,57-2)BDS	MCLEAN	88	57
			CONTRACT NO. 70D64	
		ILLINOIS FED. AID PROJECT		

Structure 057-0178 and Structure 057-0179 were originally constructed in 1977 as FAI 55, Section 57-1VB at Station 411+28.42 in McLean County. In 2003, the structures were repaired with Contract 66107 Section (57-1, 57-2)RS. The bituminous concrete overlay and waterproofing were removed. The separation between the bridge deck and steel beams at each abutment was repaired by removing 10' portion of the deck at each abutment, welding shear studs to the exposed beams, and replacing the deck. The remaining deck areas were overlaid with microsilica concrete. The expansion joints were removed and replaced with silicone joint sealer with polymer concrete nosing. The abutment bearings were replaced with elastomeric bearings. Drains within 10' of piers and abutments were plugged and other drains were extended below bottom of flanges of beams.

On S.N. 057-0178 repairs were made to the north pier cap and both abutments. On S.N. 057-0179 repairs were made to the north pier cap and backwall. The gap at the abutments and the sloped wall failure were repaired with CLSM.

The existing structures are three span steel continuous multi beam bridges. The superstructure consists of six 30" WF steel girders supporting an 8" RC deck. The superstructure is supported by dual three-column piers on spread footings on creosoted timber piles and stub abutments on concrete piles. The slopes are protected with a concrete sloped wall. The structures have an overall out-to-out width of 42'-0", and a deck (clear area) width of 38'-6" base to base of curb.

The structures have an overall length of 97'-0" from back to back of abutment. The deck has an out to out width of 42'-0", and a deck (clear area) width of 40'-0" from face to face of parapet and rail.

Traffic Barrier Terminal Type 6 Guardrail (Typ.)  
Remove and Re-erect if needed to complete Hydro-demolition

Note:  
See Sheet 2 of 13 for Proposed Work, Bill of Material, and General Notes.

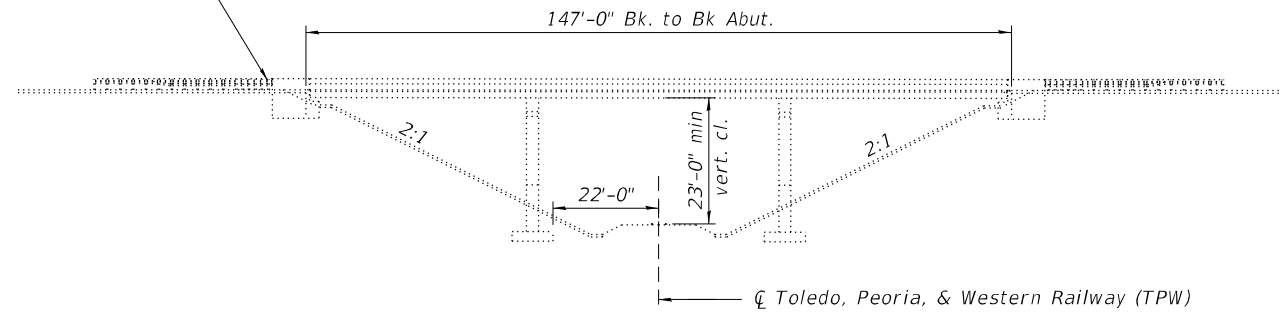

ELEVATION

**DESIGN STRESSES**  
**FIELD UNITS**

New Construction  
f<sub>c</sub> = 4,000 psi  
f<sub>y</sub> = 60,000 psi (Reinforcement)

Existing Structure  
f<sub>c</sub> = 1,200 psi (Deck Slab)  
f<sub>c</sub> = 1,400 psi (Curb, Parapet, Sub)  
f<sub>s</sub> = 20,000 psi (Reinforcement)  
f<sub>s</sub> = 20,000 psi (Structural Steel)

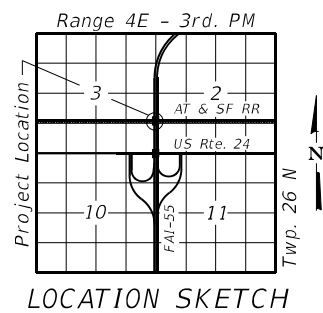

LOCATION SKETCH

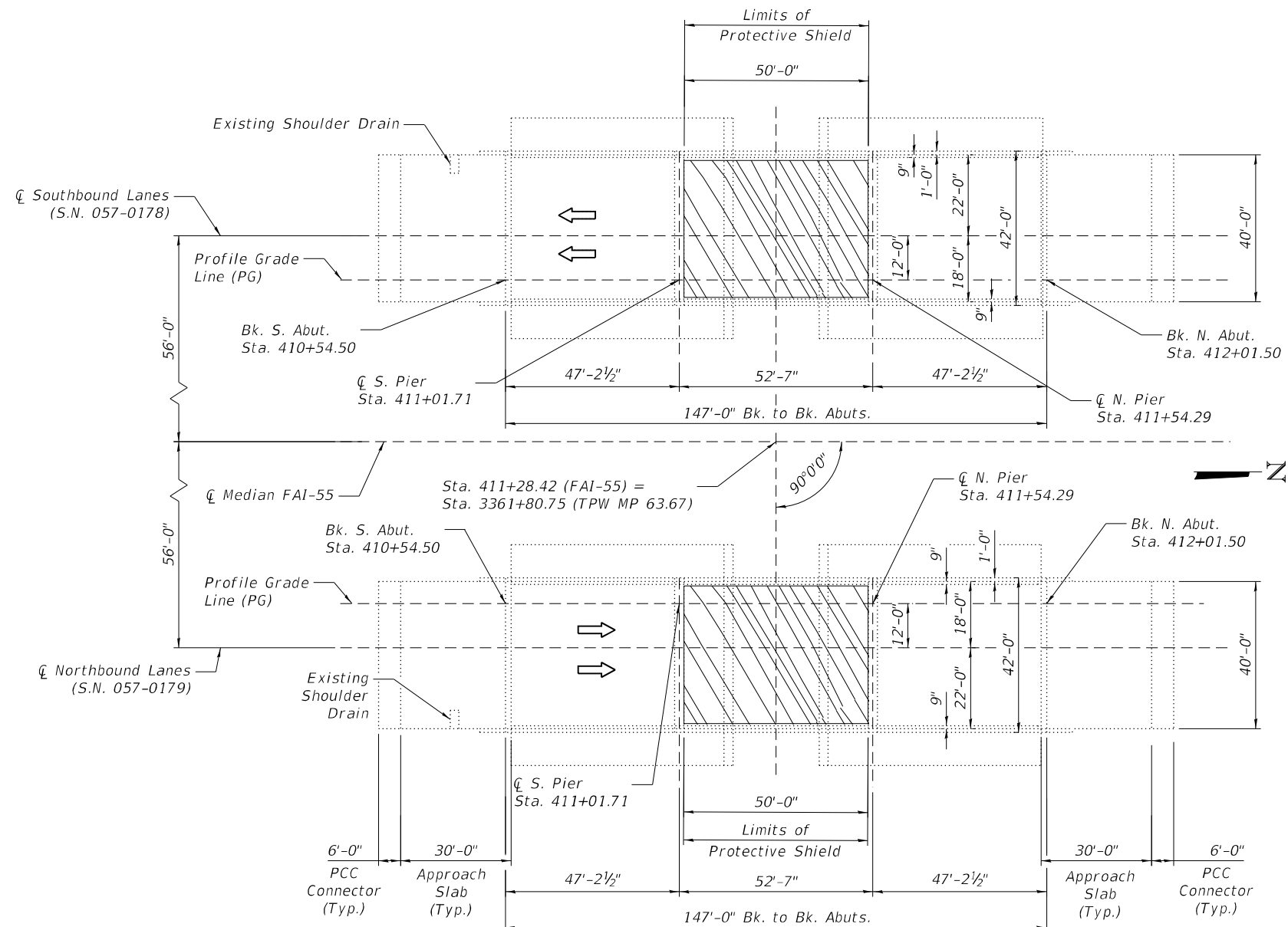

PLAN



Adam Bohnhoff  
Adam D. Bohnhoff  
Licensed Structural Engineer  
State of Illinois No. 081-007431  
Expires 11-30-2022  
Date 10-21-2021

MODEL: GPE  
FILE NAME: P:\Effingham\3454 - PTB 189 IDOT D5 V-VI\Work Order #6\Cadd\Sheet\178\178D570D64\_0178\_0179\_Combined.dgn  
10/21/2021 3:14:25 PM



CIVIL DESIGN, INC.  
WBE / DBE  
EFFINGHAM, IL  
LICENSE # 184.003222

USER NAME =	DESIGNED - KAS	REVISED -
PLOT SCALE =	CHECKED - TJZ	REVISED -
PLOT DATE =	DRAWN - DWS	REVISED -
	CHECKED - KAS	REVISED -

STATE OF ILLINOIS  
DEPARTMENT OF TRANSPORTATION

GENERAL PLAN AND ELEVATION  
S.N. 057-0178 (SB) & S.N. 057-0179 (NB)  
SHEET 1 OF 13 SHEETS

F.A.I. RTE.	SECTION	COUNTY	TOTAL SHEETS	SHEET NO.
55	(57-1,57-2)BDS	MCLEAN	88	58
CONTRACT NO. 70D64			ILLINOIS FED. AID PROJECT	

**TOTAL BILL OF MATERIAL SN 057-0178 & SN 057-0179**

Item	Unit	Total
Protective Coat	Sq. Yd.	2080
Concrete Removal	Cu. Yd.	7.6
Protective Shield	Sq. Yd.	402
Concrete Superstructure	Cu. Yd.	7.6
Reinforcement Bars, Epoxy Coated	Pound	700
Bar Splicers	Each	16
Preformed Joint Strip Seal	Foot	176
Foam, Expanding Polyurethane, High-Density	Pound	24000
Slopewall Breaking	Sq. Yd.	667
Stone Dumped Riprap, Class A4 (Special)	Sq. Yd.	667
Bridge Deck Grooving (Longitudinal)	Sq. Yd.	1150
Bridge Deck Latex Concrete Overlay, 2 1/4"	Sq. Yd.	622
Bridge Deck Latex Concrete Overlay, 3"	Sq. Yd.	1212
Bridge Deck Scarification, 2"	Sq. Yd.	622
Bridge Deck Scarification, 2 1/4"	Sq. Yd.	1212
Structural Repair of Concrete (Depth = or < 5 Inches)	Sq. Ft.	377
Deck Slab Repair (Full Depth, Type 1)	Sq. Yd.	36
Diamond Grinding (Bridge Section)	Sq. Yd.	1678
Railroad Protective Liability Insurance	L. Sum	1
Preformed Joint Seal, 1"	Foot	160

**INDEX OF SHEETS**

1. General Plan & Elevation
2. General Data
3. Existing and Proposed Typical Cross Sections
4. Stage Construction Details
5. Wearing Surface Plan
6. Floor Drain and Patching Details
7. Floor Drain Details
8. Joint Reconstruction Details - Concrete Removal (S.N. 057-0178)
9. Joint Reconstruction Details - Concrete Superstructure (S.N. 057-0179)
10. Preformed Joint Strip Seal Details
11. Shallow Concrete Repair Plan
12. Miscellaneous Details
13. Bar Splicer Assembly and Mechanical Bar Splicer Details

**PROPOSED WORK**

1. Perform Bridge Deck Scarification on Bridge Deck, Approach Slabs, and PCC Connectors.
2. Partial Removal of Deck Ends and Parapets.
3. Removal of Existing Joints.
4. Perform Full-Depth Patching and Partial Depth Repair of Approach Slabs.
5. Perform Substructure and Shallow Parapet Repairs.
6. Pour Deck Ends.
7. Insert Rubber Strip Seal into Locking Edge Rails.
8. Replace Joints at Approach Ends.
9. Pour Parapets.
10. Place Latex Concrete Overlay on Bridge Deck, Approach Slabs, and PCC Connectors.
11. Remove Slopewall.
12. Place Riprap.
13. Raise Approach Slabs to Original Elevations.
14. Apply Protective Coat.

**GENERAL NOTES**

Plan dimensions and details relative to the existing structure have been taken from existing plans and are subject to nominal construction variations. It shall be the Contractor's responsibility to verify such dimensions and details in the field and make the necessary approved adjustments prior to construction or ordering of materials. Such variations shall not be cause for additional compensation for a change in the scope of work. However, the Contractor will be paid for the quantity actually furnished at the unit price for the work.

Reinforcement bars designated (E) shall be epoxy coated.

Prior to pouring the new concrete deck, all heavy or loose rust, loose mill scale, and other loose or potentially detrimental foreign material shall be removed from the surfaces in contact with concrete. Tightly adhered paint may remain unless otherwise noted. Removal shall be accomplished by methods that will not damage the steel and the cost will be included in the pay item covering removal of the existing concrete.

Existing structural steel that will be in contact with new structural steel shall be cleaned and painted prior to erection as required by the Special Provision "Cleaning and Painting Contact Surface Areas of Existing Steel Structures".

Existing reinforcement bars extending into the removal area shall be cleaned, straightened and incorporated into the new construction. Any reinforcement bars that are damaged during concrete removal shall be replaced with approved bar splicer or anchorage system. Cost included with Concrete Removal.

Joint openings shall be adjusted according to Article 520.04 of the Std. Specs. when the deck is poured at an ambient temperature other than 50° F.

Up to 1/4" may be ground off the bridge deck and bridge approach slabs through Diamond Grinding.

Expansion joints shall be fabricated and installed according to the manufacturer's recommendations and as approved by the Engineer. Expansion joints shall be fabricated to conform to the existing cross slopes of the bridge.

Protective Coat shall be applied from end to end of approaches to entire deck surface and along the vertical faces of the parapets.

Contractor to notify G&W Public Projects Department 30 days prior to starting construction.

G&W flagging services will be required for all work within G&W right of way or any work that has a "potential to foul".

The contractor must not use the railroad right of way for storage of materials or equipment during construction. The railroad right of way must remain clear at all times. The contractor must plan and perform the work in a manner such that the railroad tracks at the project location remain fully capable of operating rail traffic throughout the work period and rail traffic is not delayed or otherwise impacted due to the work being performed.

All work performed on, above or adjacent to the railroad property shall be in accordance with the TPWR Public Project Manual. Work plans shall be submitted for review to the Railroad for all work that presents the potential to affect railroad property or operations. All work plans shall be prepared and submitted to the Railroad in adherence with the TPWR Public Project Manual, Section 1.11 Construction Submission Criteria.

Synthetic fibers shall be included in the bridge deck concrete overlay specified. See Special Provisions.

MODEL: General Notes  
FILE NAME: P:\Effingham\3454 - PTB\_189\_IDOT\_D5\_V-V\Work\_Order\_#6\Cadd\Sheet\178\0570D64\_0178\_0179\_Combined.dgn



CIVIL DESIGN, INC.  
WBE / DBE  
EFFINGHAM, IL  
LICENSE #184.003222

USER NAME =	DESIGNED - KAS	REVISED -
	CHECKED - TJZ	REVISED -
PLOT SCALE =	DRAWN - DWS	REVISED -
PLOT DATE =	CHECKED - KAS	REVISED -

**STATE OF ILLINOIS  
DEPARTMENT OF TRANSPORTATION**

**GENERAL DATA  
S.N. 057-0178 (SB) & S.N. 057-0179 (NB)**

SHEET 2 OF 13 SHEETS

F.A.I. RTE.	SECTION	COUNTY	TOTAL SHEETS	SHEET NO.
55	(57-1,57-2)BDS	MCLEAN	88	59
			CONTRACT NO. 70D64	
ILLINOIS		FED. AID PROJECT		

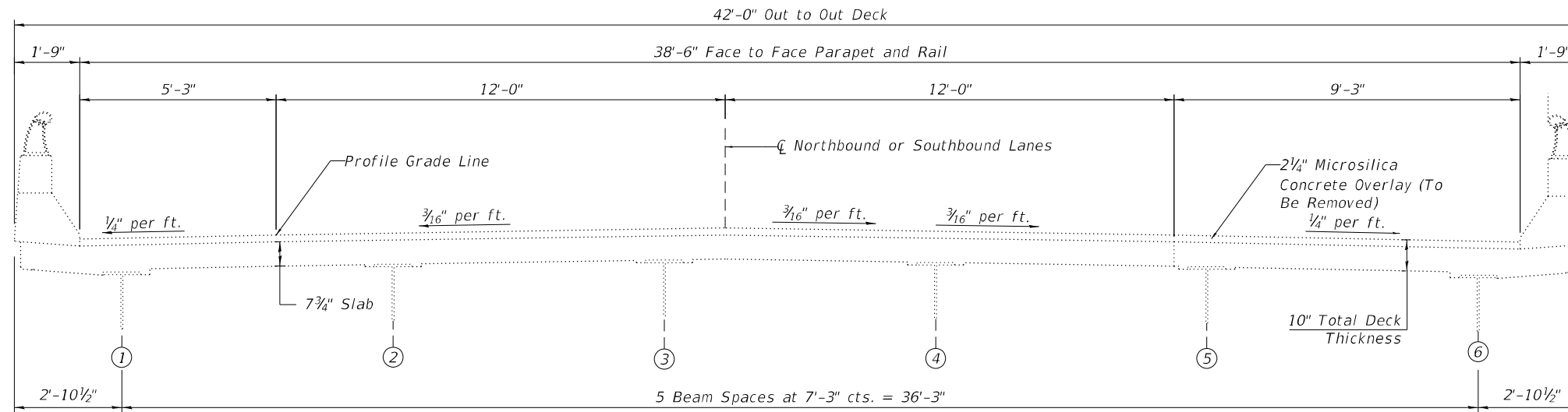

**EXISTING CROSS SECTION**

(S.N. 057-0178 Looking South)  
 (S.N. 057-0179 Looking North)

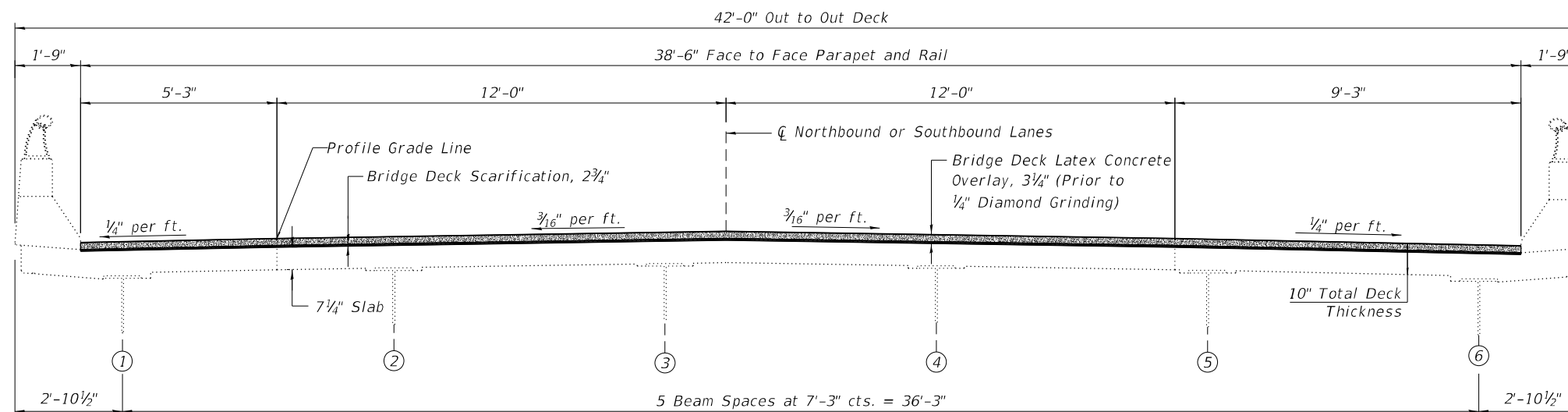

**PROPOSED CROSS SECTION**

(S.N. 057-0178 Looking South)  
 (S.N. 057-0179 Looking North)

MODEL: Cross Sections  
 FILE NAME: P:\Effingham\3454 - PTB 189 IDOT D5 V-VI\Work Order #6\Cadd\Sheet\178ID570D64\_0178\_0179\_Combined.dgn  
 10/21/2021 3:14:29 PM



**CIVIL DESIGN, INC.**  
 WBE / DBE  
 EFFINGHAM, IL  
 LICENSE # 184.003222

USER NAME =	DESIGNED - KAS	REVISED -
	CHECKED - TJZ	REVISED -
PLOT SCALE =	DRAWN - DWS	REVISED -
PLOT DATE =	CHECKED - KAS	REVISED -

**STATE OF ILLINOIS  
 DEPARTMENT OF TRANSPORTATION**

**EXISTING AND PROPOSED TYPICAL CROSS SECTIONS  
 S.N. 057-0178 (SB) & S.N. 057-0179 (NB)**

SHEET 3 OF 13 SHEETS

F.A.I. RTE.	SECTION	COUNTY	TOTAL SHEETS	SHEET NO.
55	(57-1,57-2)BDS	MCLEAN	88	60
			CONTRACT NO. 70D64	
		ILLINOIS FED. AID PROJECT		

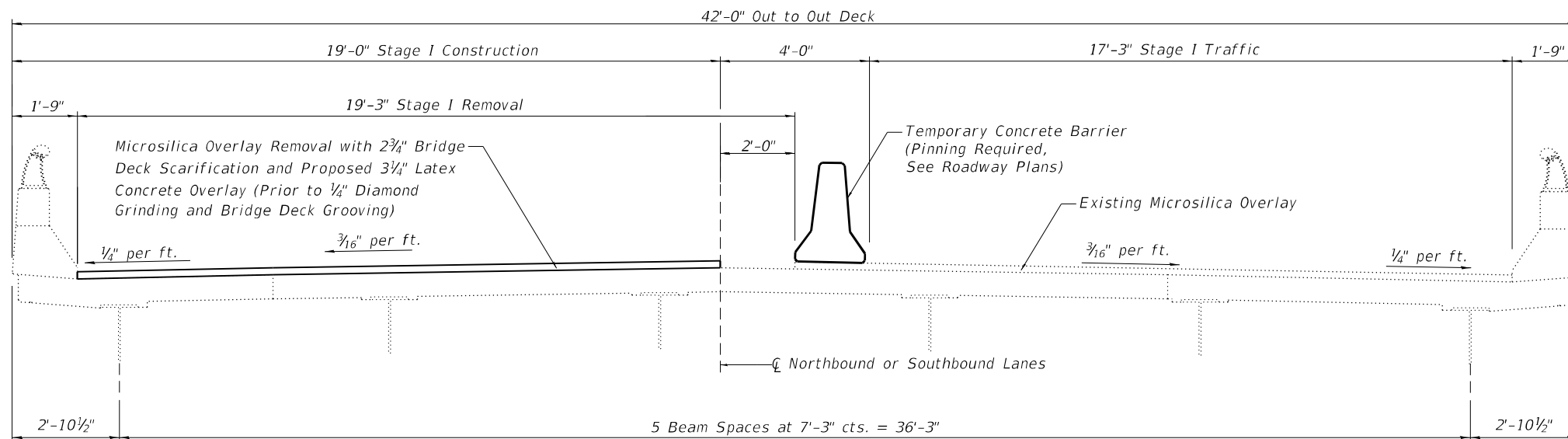

**STAGE I CONSTRUCTION DETAILS**

(S.N. 057-0178 Looking South)  
(S.N. 057-0179 Looking North)

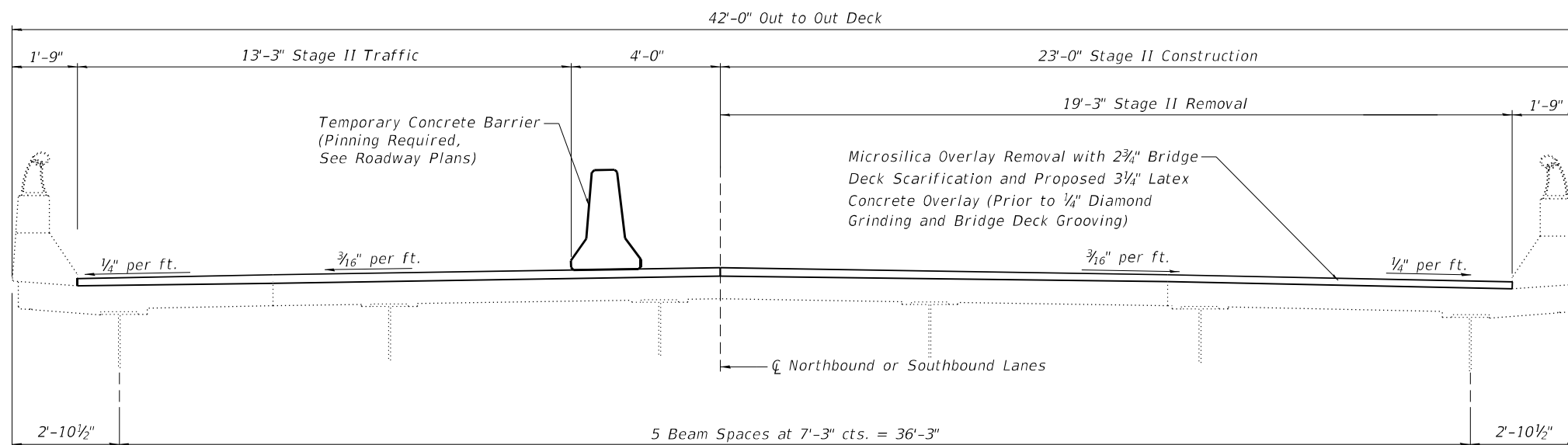

**STAGE II CONSTRUCTION DETAILS**

(S.N. 057-0178 Looking South)  
(S.N. 057-0179 Looking North)

MODEL: Stage Construction  
FILE NAME: P:\Effingham\3454 - PTB\_189\_IDOT\_D5\_V\Work\_Order\_#6\Cadd\Sheet\178ID570D64\_0178\_0179\_Combined.dgn



CIVIL DESIGN, INC.  
WBE / DBE  
EFFINGHAM, IL  
LICENSE # 184.003222

USER NAME =	DESIGNED - KAS	REVISED -
	CHECKED - TJZ	REVISED -
PLOT SCALE =	DRAWN - DWS	REVISED -
PLOT DATE =	CHECKED - KAS	REVISED -

STATE OF ILLINOIS  
DEPARTMENT OF TRANSPORTATION

STAGE CONSTRUCTION DETAILS  
S.N. 057-0178 (SB) & S.N. 057-0179 (NB)

SHEET 4 OF 13 SHEETS

F.A.I. RTE.	SECTION	COUNTY	TOTAL SHEETS	SHEET NO.
55	(57-1,57-2)BDS	MCLEAN	88	61
			CONTRACT NO. 70D64	
ILLINOIS FED. AID PROJECT				

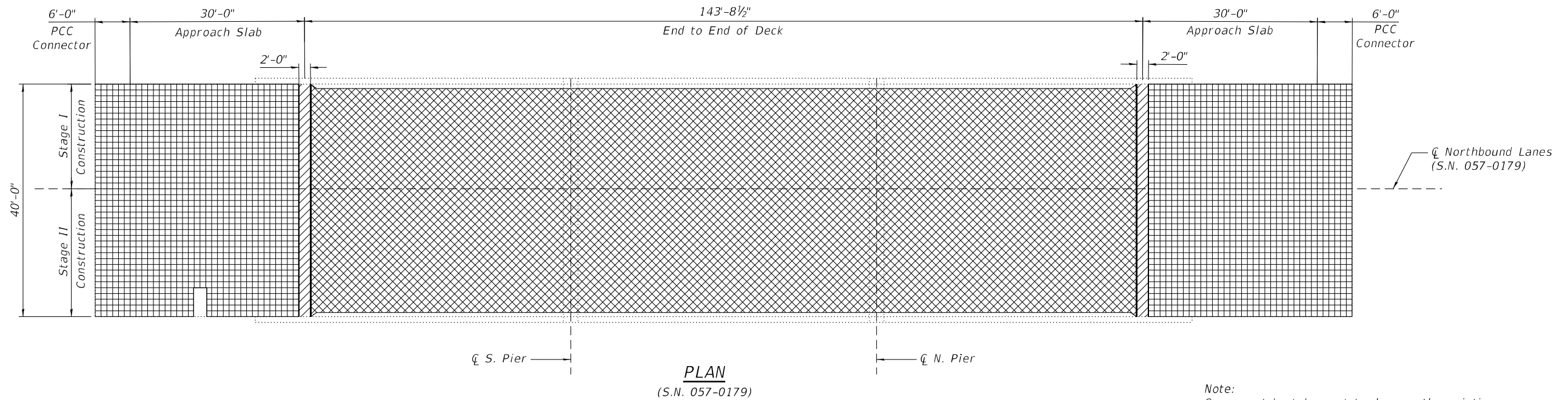
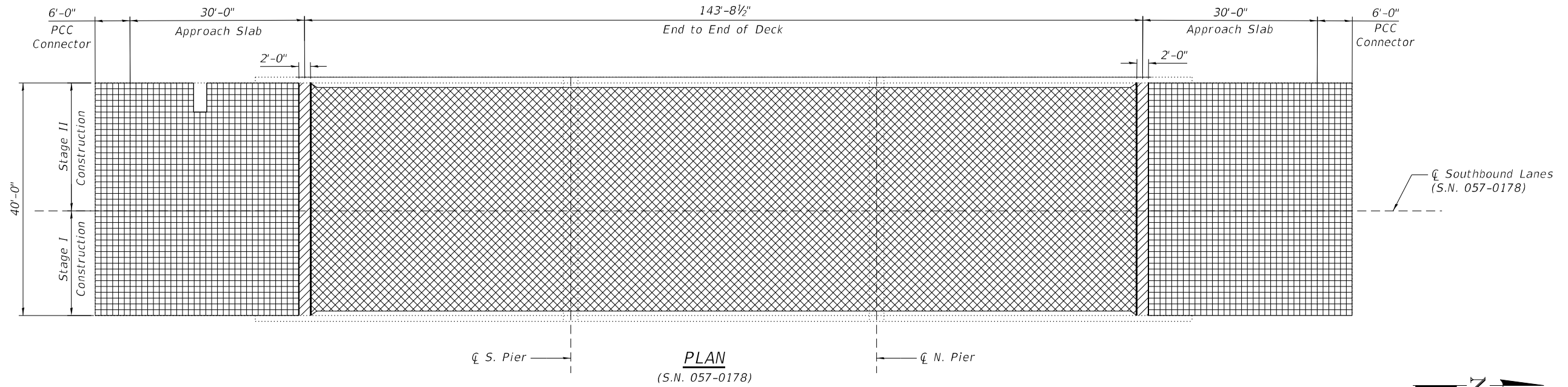

Note:  
Care must be taken not to damage the existing shoulder drains.

- Bridge Deck Scarification, 2", Bridge Deck Latex Concrete Overlay, 2 1/4", Diamond Grinding, 1/4" and Bridge Deck Grooving (Longitudinal)
- Bridge Deck Scarification, 2 3/4", Bridge Latex Concrete Overlay, 3", Diamond Grinding, 1/4" and Bridge Deck Grooving (Longitudinal)
- Diamond Grinding 1/4" and Bridge Deck Grooving (Longitudinal)

**BILL OF MATERIAL**  
(Deck & Approach)

Structure	Item	Unit	Total
057-0178	Bridge Deck Latex Concrete Overlay, 3"	Sq. Yd.	606
	Bridge Deck Latex Concrete Overlay, 2 1/4"	Sq. Yd.	311
	Bridge Deck Scarification, 2 3/4"	Sq. Yd.	606
	Bridge Deck Scarification, 2"	Sq. Yd.	311
	Bridge Deck Grooving (Longitudinal)	Sq. Yd.	575
	Diamond Grinding (Bridge Section)	Sq. Yd.	839

Structure	Item	Unit	Total
057-0179	Bridge Deck Latex Concrete Overlay, 3"	Sq. Yd.	606
	Bridge Deck Latex Concrete Overlay, 2 1/4"	Sq. Yd.	311
	Bridge Deck Scarification, 2 3/4"	Sq. Yd.	606
	Bridge Deck Scarification, 2"	Sq. Yd.	311
	Bridge Deck Grooving (Longitudinal)	Sq. Yd.	575
	Diamond Grinding (Bridge Section)	Sq. Yd.	839

MODEL: Wearing Surface  
FILE NAME: P:\Effingham\3454 - PTB\_189.IDOT.D5.V\Work Order #6\Cadd\Sheet\178\0570178\_0179\_Combined.dgn



USER NAME =	DESIGNED - KAS	REVISED -
	CHECKED - TJZ	REVISED -
PLOT SCALE =	DRAWN - DWS	REVISED -
PLOT DATE =	CHECKED - KAS	REVISED -

**STATE OF ILLINOIS**  
**DEPARTMENT OF TRANSPORTATION**

**WEARING SURFACE**  
**S.N. 057-0178 (SB) & S.N. 057-0179 (NB)**

SHEET 5 OF 13 SHEETS

F.A.I. RTE.	SECTION	COUNTY	TOTAL SHEETS	SHEET NO.
55	(57-1.57-2)BDS	MCLEAN	88	62
			CONTRACT NO. 70D64	
ILLINOIS FED. AID PROJECT				

MODEL: Patching  
 FILE NAME: P:\Effingham\3454 - PTB 189 IDOT D5 V-V\Work Order #6\Cadd\Sheet\178\1D570D64\_0178\_0179\_Combined.dgn  
 11/29/2021 1:00:34 PM

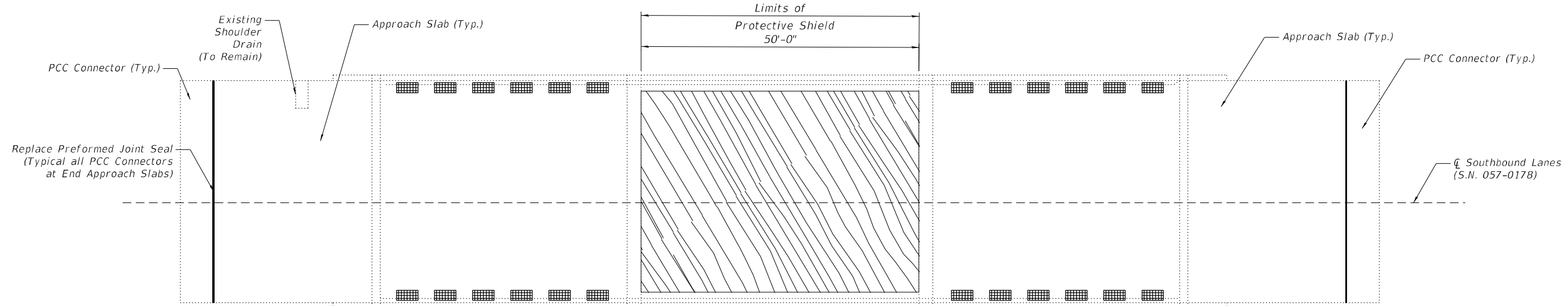

**PLAN**

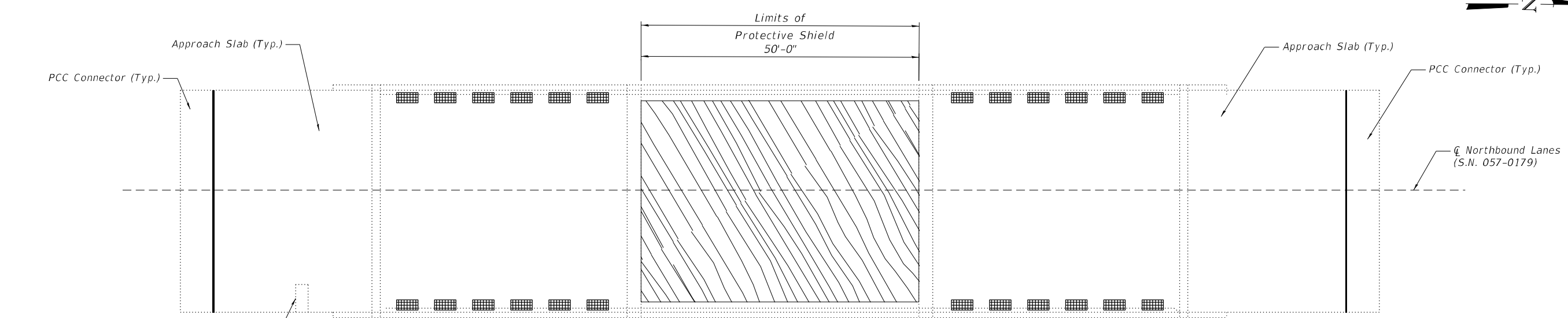

**PLAN**

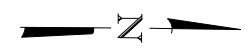

**LEGEND**

Deck Slab Repair (Full Depth, Type I) at all Drain Locations. All repair areas are 2'-0" x 1'-1", unless otherwise noted.

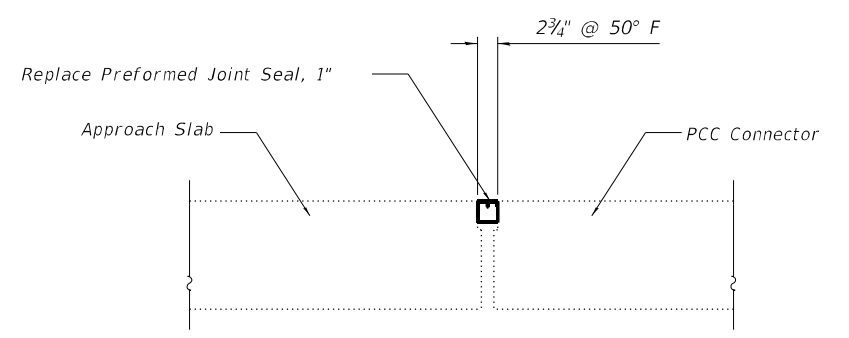

**PREFORMED JOINT REPLACEMENT DETAIL**  
 (North & South Approach Both Structures)

**BILL OF MATERIAL**

Structure	Item	Unit	Total
057-0178	Deck Slab Repair (Full Depth, Type I)	Sq. Yd.	18
057-0178	Preformed Joint Seal, 1"	Foot	80
057-0178	Protective Shield	Sq. Yd.	201
057-0179	Deck Slab Repair (Full Depth, Type I)	Sq. Yd.	18
057-0179	Preformed Joint Seal, 1"	Foot	80
057-0179	Protective Shield	Sq. Yd.	201

**NOTES:**

Patch sizes shown represent conditions at the time the plans were completed. An Estimated 2% of the Deck Area has been included should additional Deck Slab Repair (Full Depth, Type I) be required after Bridge Deck Scarification.

The actual sizes and locations of patching shall be determined by the Resident Engineer after removal of the wearing surface, before patching operations begin. The Engineer Shall show the actual locations of the deck repairs on this sheet.

The existing drains and extensions shall be removed. Cost included with Deck Slab Repair (Full Depth, Type I).

Care must be taken not to damage the existing shoulder drains.

Extreme care must be used when removing concrete near the top flange of the beams. The Contractor is responsible for any damage to the beams.



USER NAME =	DESIGNED - KAS	REVISED -
	CHECKED - TJZ	REVISED -
PLOT SCALE =	DRAWN - DWS	REVISED -
PLOT DATE =	CHECKED - KAS	REVISED -

**STATE OF ILLINOIS  
 DEPARTMENT OF TRANSPORTATION**

**FLOOR DRAIN AND PATCHING DETAILS  
 S.N. 057-0178 (SB) & S.N. 057-0179 (NB)**

SHEET 6 OF 13 SHEETS

F.A.I. RTE.	SECTION	COUNTY	TOTAL SHEETS	SHEET NO.
55	(57-1,57-2)BDS	MCLEAN	88	63
			CONTRACT NO. 70D64	
ILLINOIS FED. AID PROJECT				



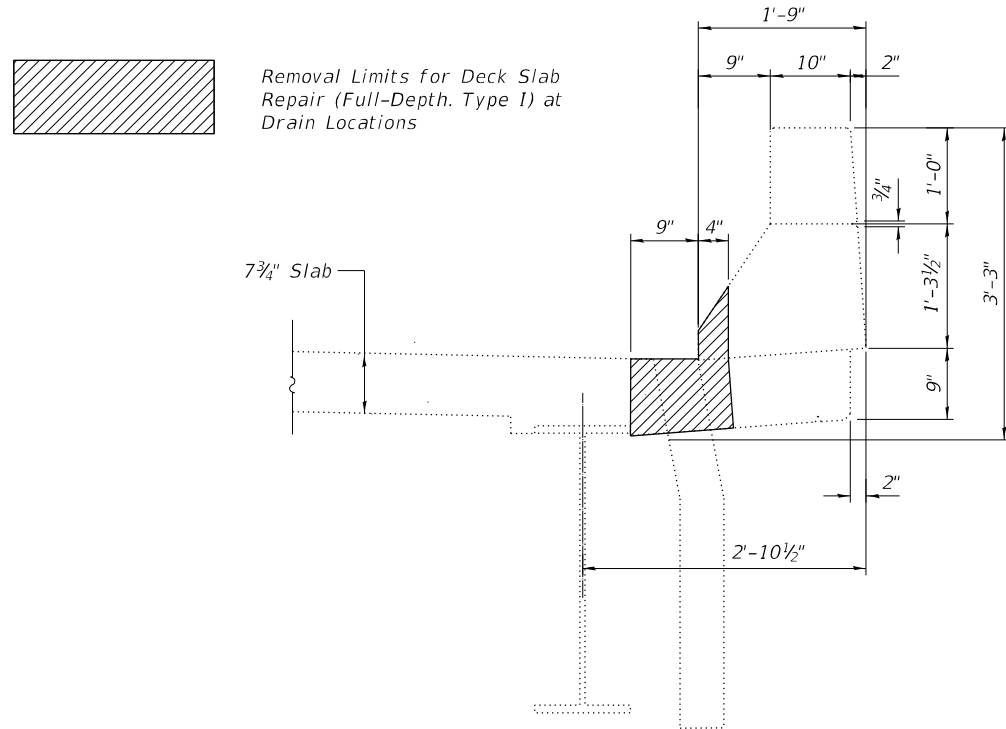

**NOTES:**

Cost of removal of existing drains and extensions is included in Deck Slab Repair (Full Depth, Type 1)

TYPICAL FLOOR DRAIN REMOVAL LIMITS

MODEL: Floor Drain  
 FILE NAME: P:\Effingham\3454 - PTB 189 IDOT D5 V-V\Work Order #6\Cadd\Sheet\178ID570D64\_0178\_0179\_Combined.dgn  
 10/21/2021 3:14:33 PM



CIVIL DESIGN, INC.  
 WBE / DBE  
 EFFINGHAM, IL  
 LICENSE # 184.003222

USER NAME =	DESIGNED - KAS	REVISED -
	CHECKED - TJZ	REVISED -
PLOT SCALE =	DRAWN - DWS	REVISED -
PLOT DATE =	CHECKED - KAS	REVISED -

STATE OF ILLINOIS  
 DEPARTMENT OF TRANSPORTATION

FLOOR DRAIN DETAILS  
 S.N. 057-0178 (SB) & S.N. 057-0179 (NB)

SHEET 7 OF 13 SHEETS

F.A.I. RTE.	SECTION	COUNTY	TOTAL SHEETS	SHEET NO.
55	(57-1,57-2)BDS	MCLEAN	88	64
			CONTRACT NO. 70D64	
ILLINOIS FED. AID PROJECT				

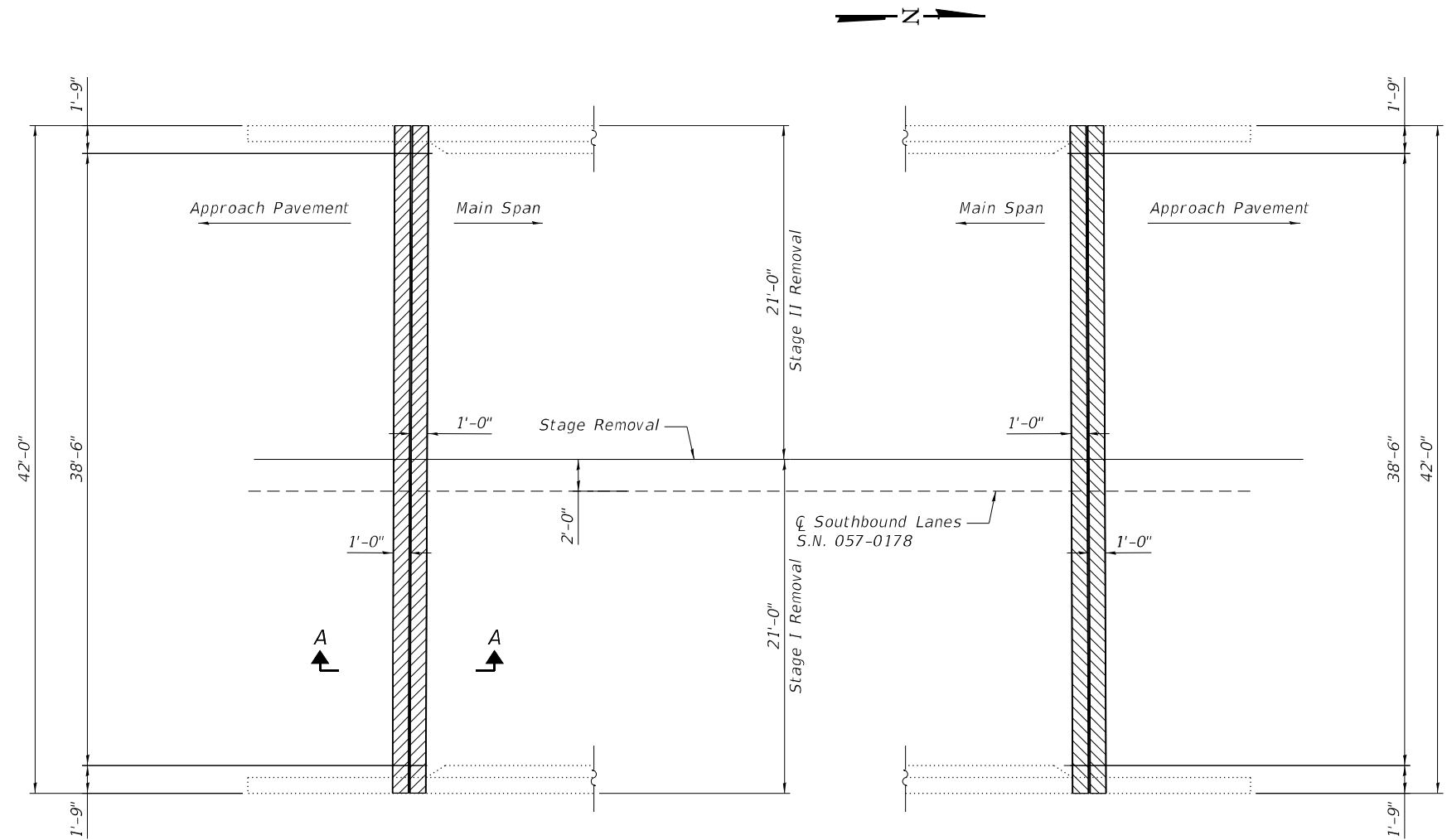

**SOUTH ABUTMENT PLAN**

**NORTH ABUTMENT PLAN**

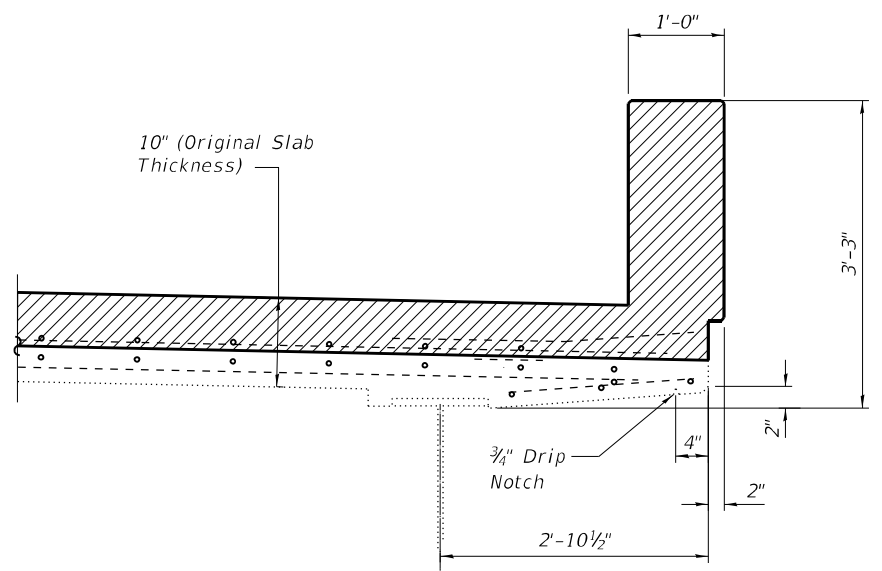

**SECTION AT PARAPET**

Note:  
All Existing Reinforcement to remain in place.

Note: S.N. 057-0178 shown, S.N. 057-0179 similar

**NOTES:**

Existing reinforcement bars extending into the removal area shall be cleaned, straightened and incorporated into the New Construction. Any reinforcement bars that are damaged during Concrete Removal shall be replaced with an approved bar splicer or anchorage system. Cost included with Concrete Removal.

The existing expansion joint system shall be removed completely, as well as any foreign material that has accumulated or been placed in the joint openings. The cost for this work is included in Concrete Removal and no additional compensation will be allowed.

The handrail attached to the top of the parapets shall be unbolted to allow for the removal and placement of the parapet ends. Following completion of the parapet ends, the handrail shall be re-attached. The cost of this work shall be included in Concrete Superstructures.

All existing deck tie downs shall be removed. Cost included with Concrete Removal.

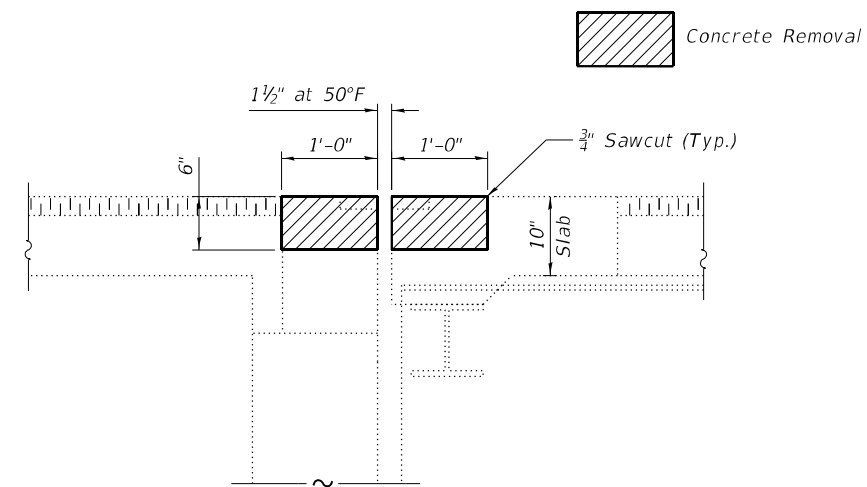

**SECTION A-A**

**BILL OF MATERIAL**

Structure	Item	Unit	Total
057-0178	Concrete Removal	Cu. Yd.	3.8
057-0179	Concrete Removal	Cu. Yd.	3.8

MODEL: Joint Recon  
FILE NAME: P:\Effingham\3454 - PTB\_189\_IDOT\_D5\_V-VI\Work\_Order\_#6\Cadd\Sheet\178ID570D64\_0178\_0179\_Combined.dgn  
11/29/2021 1:01:03 PM

USER NAME =	DESIGNED - KAS	REVISED -
PLOT SCALE =	CHECKED - TJZ	REVISED -
PLOT DATE =	DRAWN - DWS	REVISED -
	CHECKED - KAS	REVISED -

**STATE OF ILLINOIS  
DEPARTMENT OF TRANSPORTATION**

**JOINT RECONSTRUCTION DETAILS - CONCRETE REMOVAL  
S.N. 057-0178 (SB) & S.N. 057-0179 (NB)**

SHEET 8 OF 13 SHEETS

F.A.I. RTE.	SECTION	COUNTY	TOTAL SHEETS	SHEET NO.
55	(57-1,57-2)BDS	MCLEAN	88	65
			CONTRACT NO. 70D64	
ILLINOIS FED. AID PROJECT				

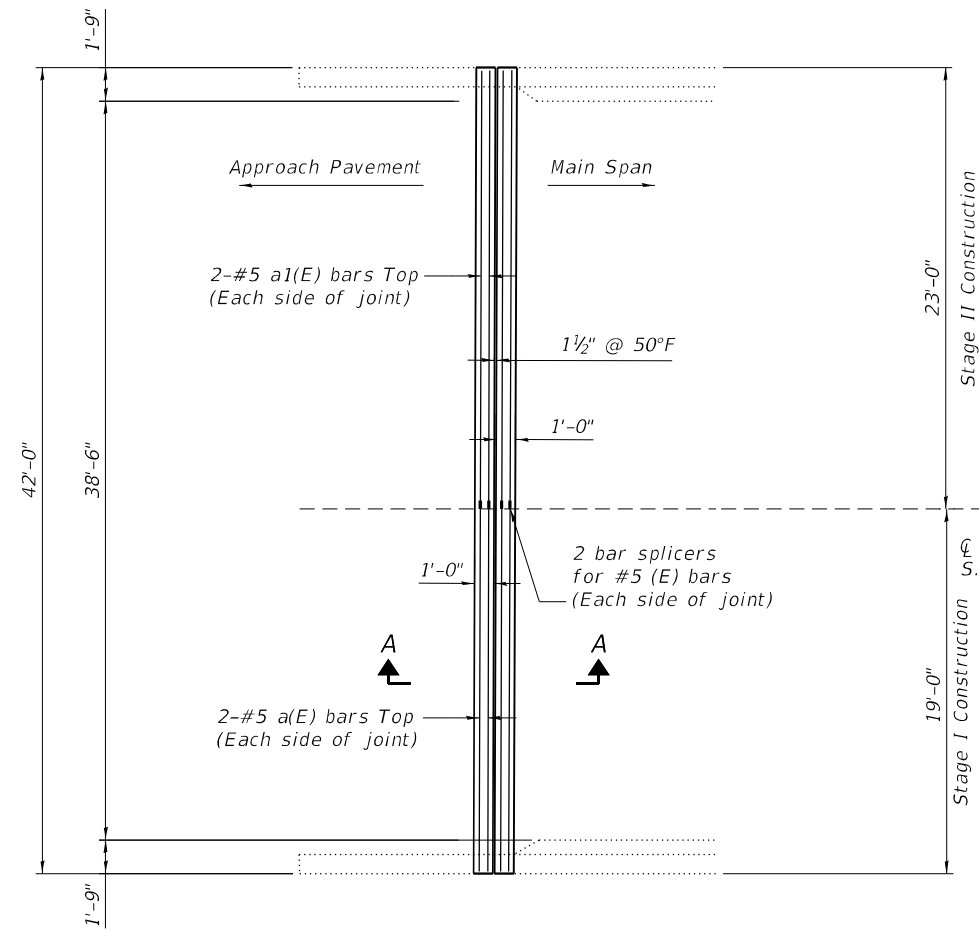
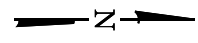

**SOUTH ABUTMENT PLAN**

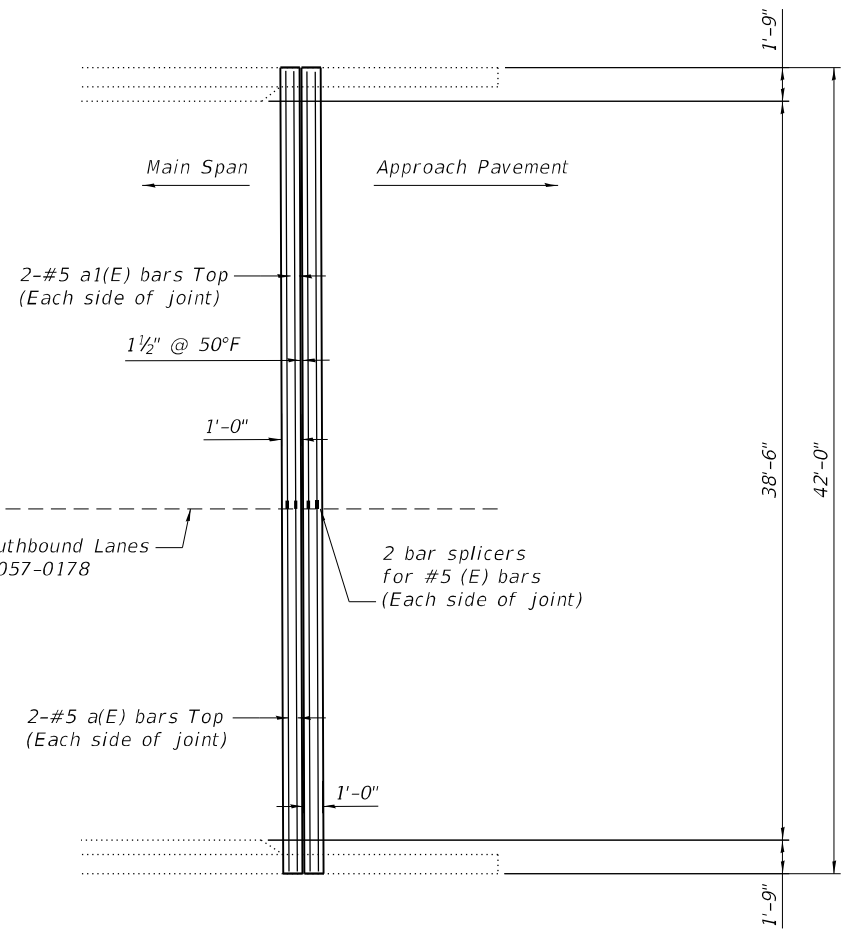

**NORTH ABUTMENT PLAN**

Note: S.N. 057-0178 shown, S.N. 057-0179 similar

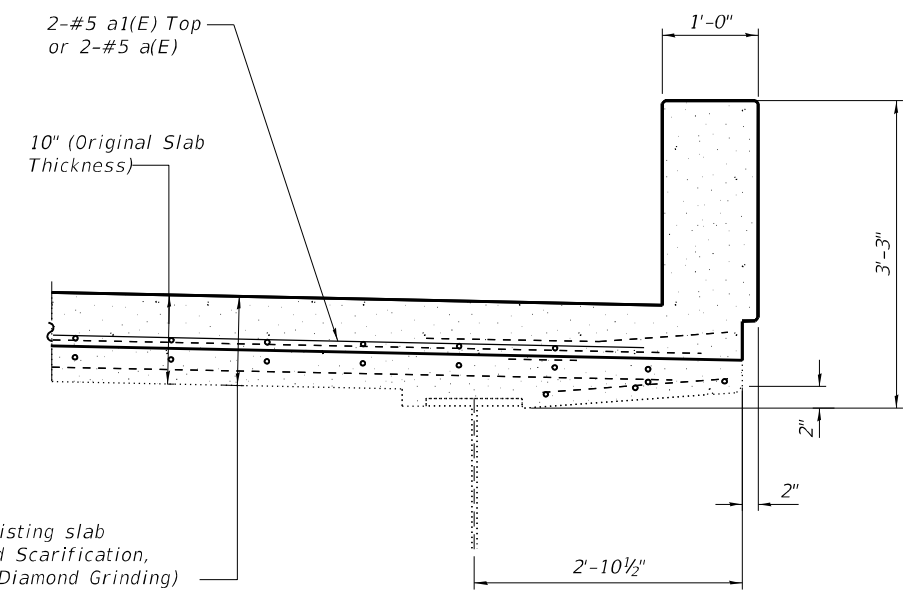

**SECTION AT PARAPET**

Note:  
All Existing Reinforcement to remain in Place.

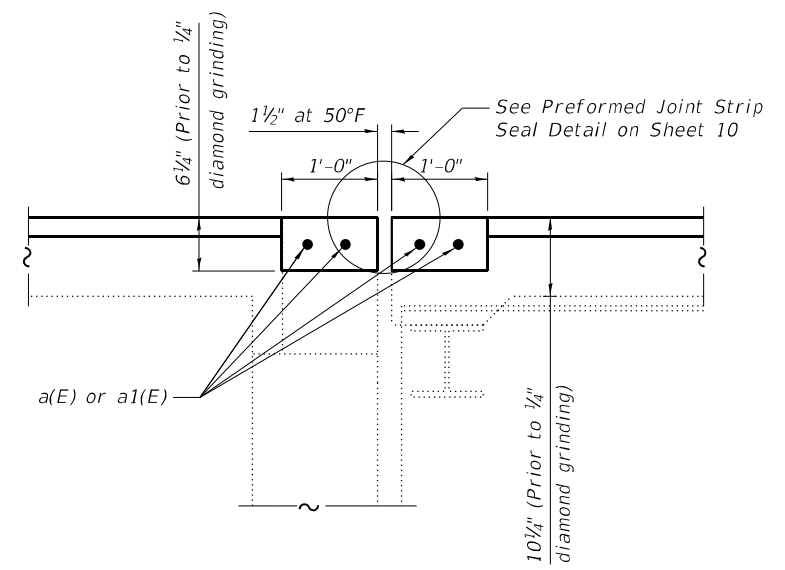

**SECTION A-A**

**BILL OF MATERIAL**  
(S.N. 057-0178)

Bar	No.	Size	Length	Shape	
a(E)	8	#5	18'-9"	—	
a1(E)	8	#5	22'-8"	—	
Reinforcement Bars, Epoxy Coated				Pound	350
Concrete Superstructure				Cu. Yd.	3.8

**BILL OF MATERIAL**  
(S.N. 057-0179)

Bar	No.	Size	Length	Shape	
a(E)	8	#5	18'-9"	—	
a1(E)	8	#5	22'-8"	—	
Reinforcement Bars, Epoxy Coated				Pound	350
Concrete Superstructure				Cu. Yd.	3.8

MODEL: Joint Recon2  
FILE NAME: P:\Effingham\3454 - PTB\_189\_IDOT\_D5\_VAVWork\_Order\_#6\Cadd\Sheet\178ID570D64\_0178\_0179\_Combined.dgn  
11/29/2021 1:01:28 PM

**CIVIL DESIGN, INC.**  
WBE / DBE  
EFFINGHAM, IL  
LICENSE # 184.003222

USER NAME =	DESIGNED - KAS	REVISED -
PLOT SCALE =	CHECKED - TJZ	REVISED -
PLOT DATE =	DRAWN - DWS	REVISED -
	CHECKED - KAS	REVISED -

**STATE OF ILLINOIS**  
**DEPARTMENT OF TRANSPORTATION**

**JOINT RECONSTRUCTION DETAILS - CONCRETE SUPERSTRUCTURE**  
**S.N. 057-0178 (SB) & 057-0179 (NB)**

SHEET 9 OF 13 SHEETS

F.A.I. RTE.	SECTION	COUNTY	TOTAL SHEETS	SHEET NO.
55	(57-1,57-2)BDS	MCLEAN	88	66
CONTRACT NO. 70D64				
ILLINOIS FED. AID PROJECT				

MODEL: Strip Seal  
 FILE NAME: P:\Effingham\3454 - PTB 189 IDOT D5 V-V\Work Order #6\Cadd\Sheet\178ID570D64\_0178\_0179\_Combined.dgn

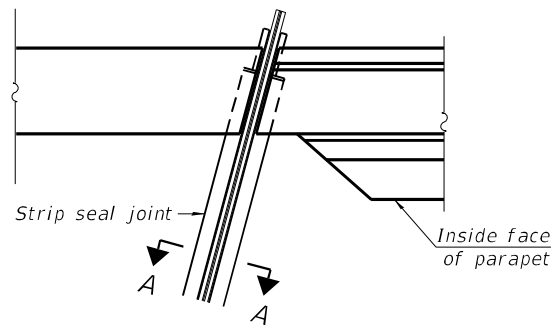

PLAN AT PARAPET

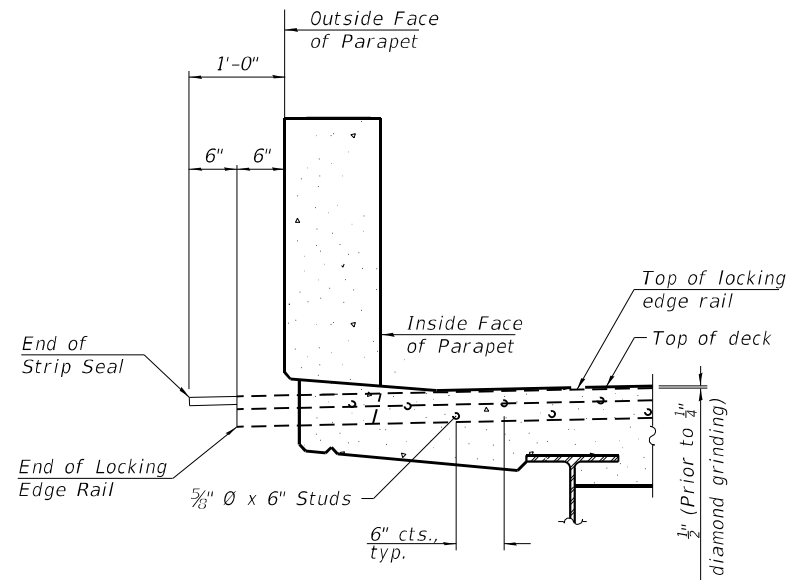

ELEVATION AT PARAPET

**Notes:**  
 The strip seal shall be made continuous and shall have a minimum thickness of 1/4". The configuration of the strip seal shall match the configuration of the locking edge rails. Open or "webbed" strip seal gland configurations are not permitted. The gland shall be sized for a maximum rated movement of 4 inches.  
 The locking edge rails depicted are configured for typical applications and are conceptual only. The actual configuration of the locking edge rails and matching strip seal may vary from manufacturer to manufacturer provided they fit the application and meet the minimum anchorage shown. Flanged edge rails, however, will not be allowed. Locking edge rails may exceed the 4 1/2" maximum depth provided the anchorage system is revised according to the manufacturer's recommendation.  
 The manufacturer's recommended installation methods shall be followed.  
 All steel components shall be galvanized after fabrication according to Article 520.03 of the Standard Specifications.  
 The Maximum space between locking edge rail segments shall be 3/16" and sealed with a suitable sealant; however, any rail joint within 10' measured perpendicular to the face of the curb or parapet shall be welded as shown in the locking edge rail splice detail.  
 The concrete opening below the strip seal will vary based on the locking edge rail chosen by the Contractor. Deck and parapet lengths shown elsewhere in the plans are dimensioned to the concrete opening, not the joint opening, and are based on the rolled locking edge rail. If the Contractor elects to use a different locking edge rail, dimensional adjustments may be required. One exception to this would be the strip seal joint at the end of the precast bridge approach slab. For these cases the pavement connector length shall be adjusted, not the length of the bridge approach slab.

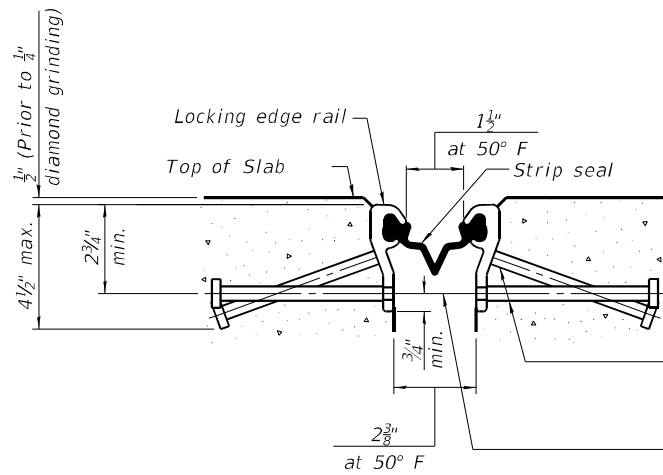

SHOWING ROLLED RAIL JOINT

\* 5/8"  $\phi$  x 6" studs @ 6" cts. (alternate angled/bent studs with horizontal studs)  
 \* 3/8"  $\phi$  threaded rods in 7/16"  $\phi$  holes at  $\pm 4'-0"$  cts. for holding the proper joint opening based on the temperature during the deck pour. Place to miss studs. All rods shall be burned, or sawed off flush with the plates after concrete is set.

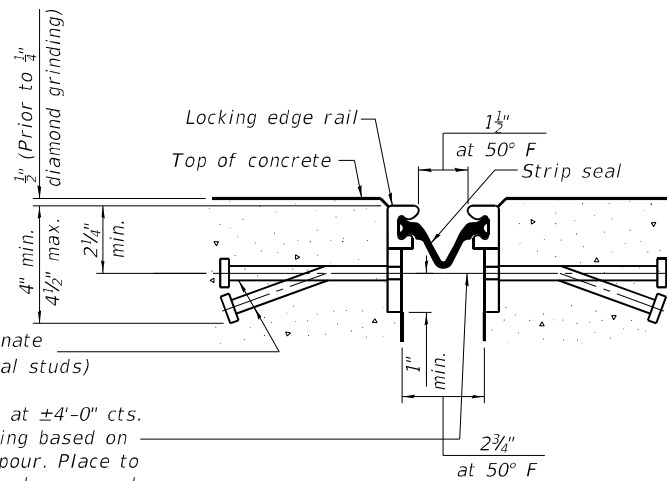

SHOWING WELDED RAIL JOINT

SECTION A-A  
 \* Granular or solid flux filled headed studs conforming to Article 1006.32 of the Std. Specs., automatically end welded.

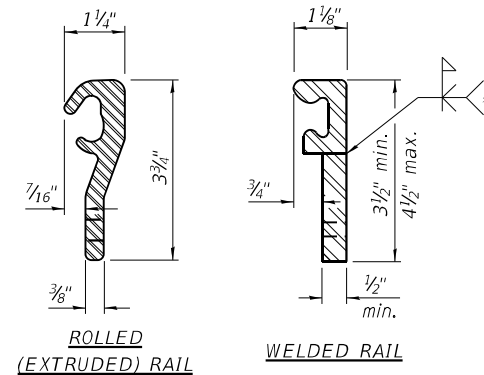

LOCKING EDGE RAILS

\*\* Back gouge not required if complete joint penetration is verified by mock-up.

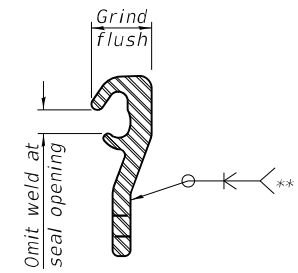

LOCKING EDGE RAIL SPLICE  
 The inside of the locking edge rail groove shall be free of weld residue. Rolled rail shown, welded rail similar.

BILL OF MATERIAL

Structure	Item	Unit	Total
057-0178	Preformed Joint Strip Seal	Foot	88
057-0179	Preformed Joint Strip Seal	Foot	88



CIVIL DESIGN, INC.  
 WBE / DBE  
 EFFINGHAM, IL  
 LICENSE # 184.003222

USER NAME =	DESIGNED - KAS	REVISED -
PLOT SCALE =	CHECKED - TJZ	REVISED -
PLOT DATE =	DRAWN - DWS	REVISED -
	CHECKED - KAS	REVISED -

STATE OF ILLINOIS  
 DEPARTMENT OF TRANSPORTATION

PREFORMED STRIP SEAL DETAILS  
 S.N. 057-0178 (SB) & S.N. 057-0179 (NB)

SHEET 10 OF 13 SHEETS

F.A.I. RTE.	SECTION	COUNTY	TOTAL SHEETS	SHEET NO.
55	(57-1,57-2)BDS	MCLEAN	88	67
ILLINOIS FED. AID PROJECT			CONTRACT NO. 70D64	

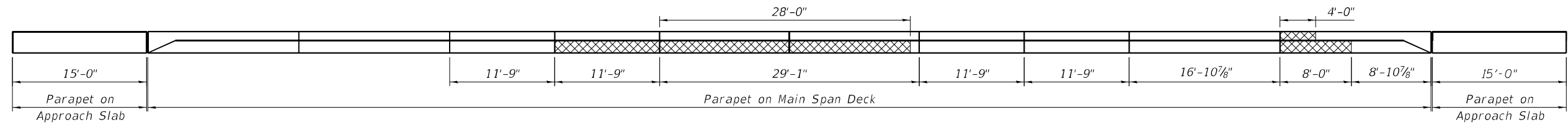

S.N. 057-0178 EAST PARAPET ELEVATION

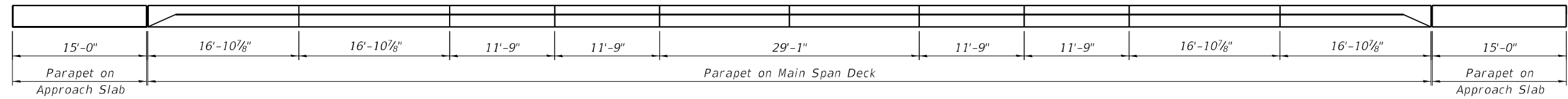

S.N. 057-0178 WEST PARAPET ELEVATION

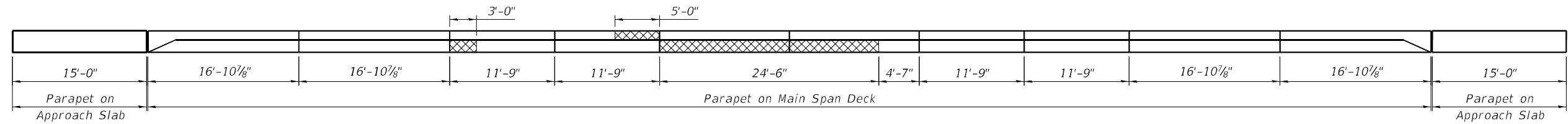

S.N. 057-0179 EAST PARAPET ELEVATION

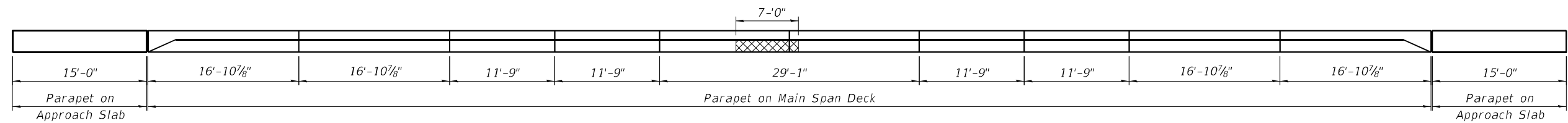

S.N. 057-0179 WEST PARAPET ELEVATION

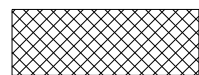
 Structural Repair of Concrete  
Depth Equal To or Less than 5"

S.N. 057-0178  
TABLE FOR STRUCTURAL REPAIR OF CONCRETE

ABUTMENT CORNER	Repair Area Dimensions				Repair Area Sq. Ft.
	Wingwall		Backwall		
	A	B	C	D	
Northeast	3	4	2	3	18
Southeast	3	3	2	5	19
Northwest	4	5	3	4	32
Southwest	3	3	3	5	24

S.N. 057-0179  
TABLE FOR STRUCTURAL REPAIR OF CONCRETE

ABUTMENT CORNER	Repair Area Dimensions				Repair Area Sq. Ft.
	Wingwall		Backwall		
	A	B	C	D	
Northeast	3	4	2	3	18
Southeast	2	3	3	2	12
Northwest	4	5	3	4	32
Southwest	3	4	3	3	21

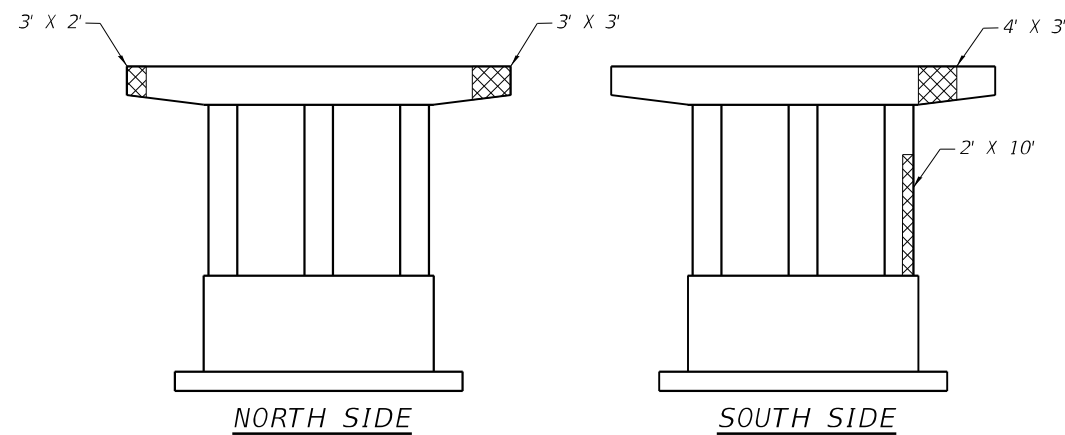

S.N. 057-0178 NORTH PIER

SECTION THRU PARAPET

Showing Typical Removal Limits for Structural Repair of Concrete on Parapets

BILL OF MATERIAL

Structure	Item	Unit	Total
057-0178	Structural Repair of Concrete, Depth Equal to or Less than 5"	Sq. Ft.	230
057-0179	Structural Repair of Concrete, Depth Equal to or Less than 5"	Sq. Ft.	147

Note:

See Special Provision for Structural Repair of Concrete.

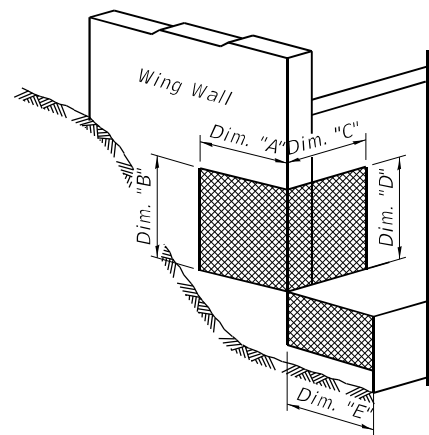

MODEL: Shallow Repairs  
FILE NAME: P:\Effingham\3454 - PTB 189 IDOT D5 V-VI\Work Order #6\Cadd\Sheet\178\0570D64\_0178\_0179\_Combined.dgn  
11/29/2021 1:02:00 PM



CIVIL DESIGN, INC.  
WBE / DBE  
EFFINGHAM, IL  
LICENSE # 184.003222

USER NAME =	DESIGNED - KAS	REVISED -
PLOT SCALE =	CHECKED - TJZ	REVISED -
PLOT DATE =	DRAWN - DWS	REVISED -
	CHECKED - KAS	REVISED -

STATE OF ILLINOIS  
DEPARTMENT OF TRANSPORTATION

SHALLOW CONCRETE REPAIR PLAN  
S.N. 057-0178 (SB) & S.N. 057-0179 (NB)

SHEET 11 OF 13 SHEETS

F.A.I. RTE.	SECTION	COUNTY	TOTAL SHEETS	SHEET NO.
55	(57-1,57-2)BDS	MCLEAN	88	68
			CONTRACT NO. 70D64	
		ILLINOIS FED. AID PROJECT		

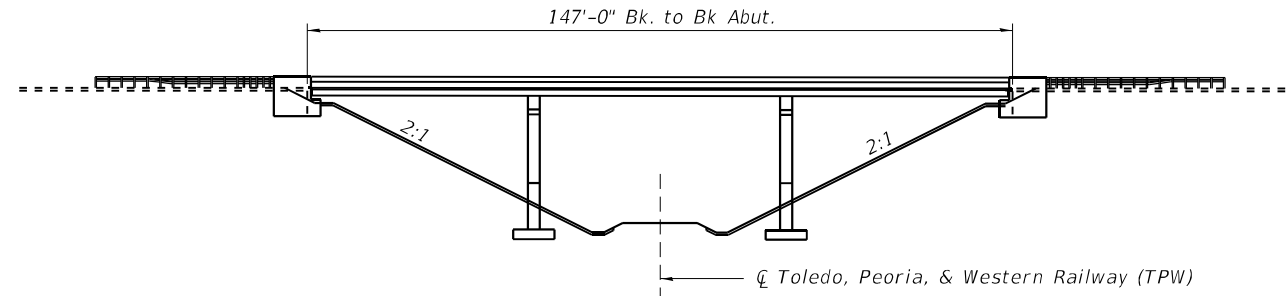

ELEVATION

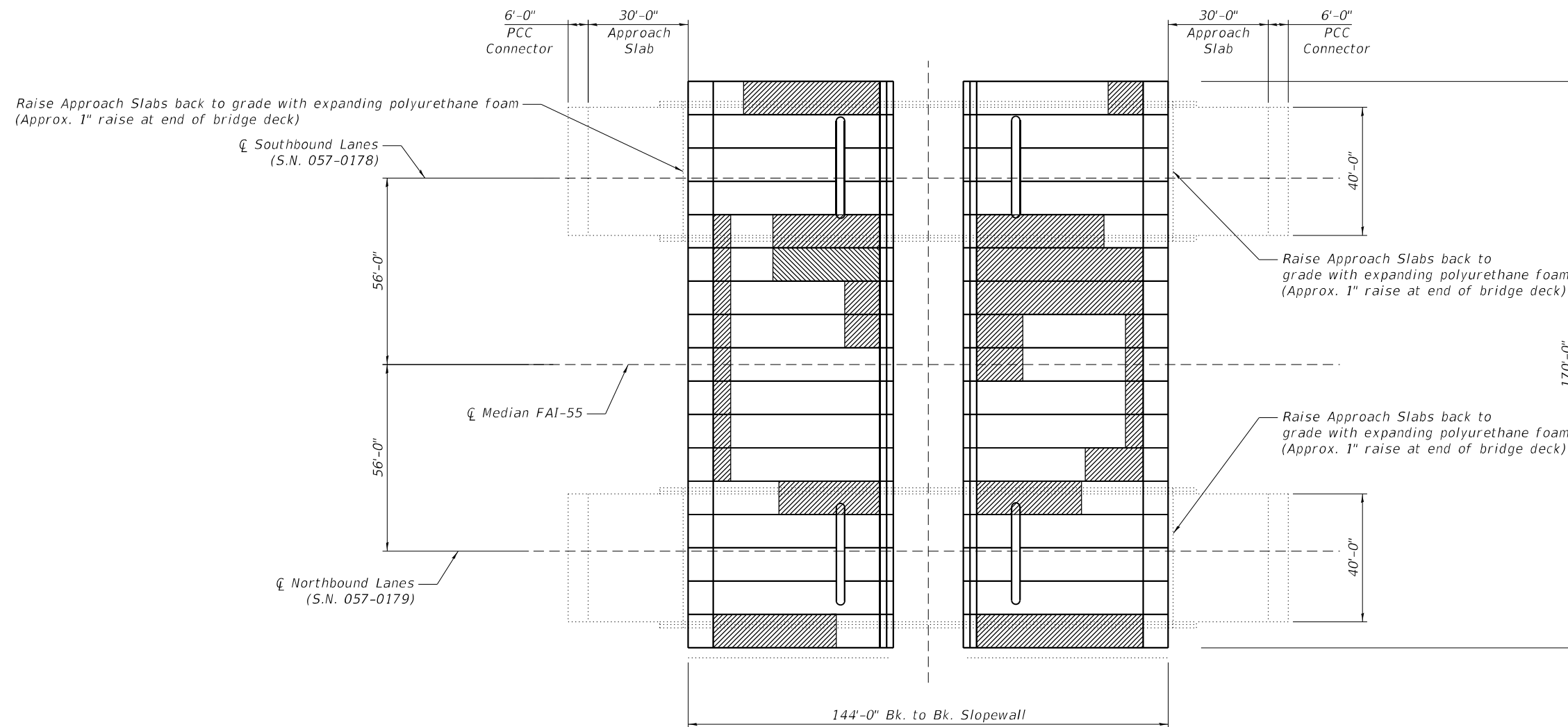

PLAN

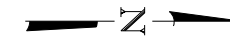

Slopewall Breaking & Stone Dumped Riprap, Class A4 (Special) (See Special Provisions)

Note:  
Locations of slopewall repairs are approximate. Actual locations to be as directed by the Engineer in the field.

**BILL OF MATERIAL**

Structure	Item	Unit	Total
Total	Slopewall Breaking	Sq. Yd.	667
Total	Stone Dumped Riprap, Class A4 (Special)	Sq. Yd.	667
057-0178	Foam, Expanding Polyurethane, High-Density	Pound	12000
057-0179	Foam, Expanding Polyurethane, High-Density	Pound	12000

MODEL: Misc. Repairs  
FILE NAME: P:\Effingham\3454 - PTB\_189\_IDOT D5 V-V\Work Order #6\Cadd\Sheet\178ID570D64\_0178\_0179\_Combined.dgn  
11/29/2021 1:02:36 PM



CIVIL DESIGN, INC.  
WBE / DBE  
EFFINGHAM, IL  
LICENSE # 184.003222

USER NAME =	DESIGNED - KAS	REVISED -
	CHECKED - TJZ	REVISED -
PLOT SCALE =	DRAWN - DWS	REVISED -
PLOT DATE =	CHECKED - KAS	REVISED -

STATE OF ILLINOIS  
DEPARTMENT OF TRANSPORTATION

MISCELLANEOUS REPAIRS  
S.N. 057-0178 (SB) & S.N. 057-0179 (NB)

SHEET 12 OF 13 SHEETS

F.A.I. RTE.	SECTION	COUNTY	TOTAL SHEETS	SHEET NO.
55	(57-1,57-2)BDS	MCCLEAN	88	69
			CONTRACT NO. 70D64	
		ILLINOIS FED. AID PROJECT		

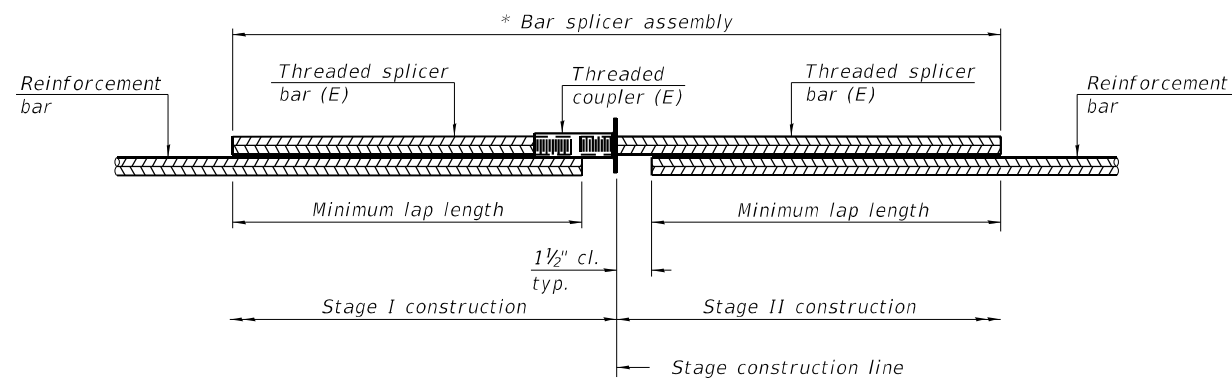

**STANDARD BAR SPLICER ASSEMBLY PLAN**  
 (All components shall be provided from one supplier)

Threaded splicer bar length = min. lap length + 1 1/2" + thread length

\* Epoxy not required on Bar Splicer Assembly components used in conjunction with black bars.

Structure	Location	Bar size	No. assemblies required	Minimum lap length
057-0178	Deck End	#5	8	3'-6"
057-0179	Deck End	#5	8	3'-6"

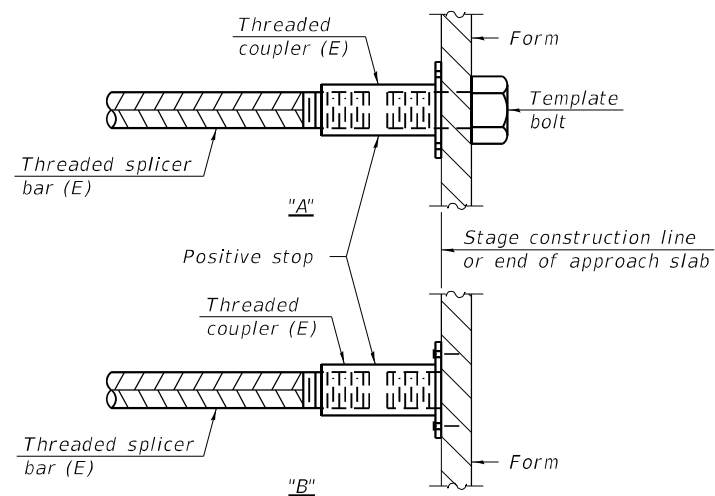

**INSTALLATION AND SETTING METHODS**

"A" : Set bar splicer assembly by means of a template bolt.  
 "B" : Set bar splicer assembly by nailing to wood forms or cementing to steel forms.  
 (E) : Indicates epoxy coating.

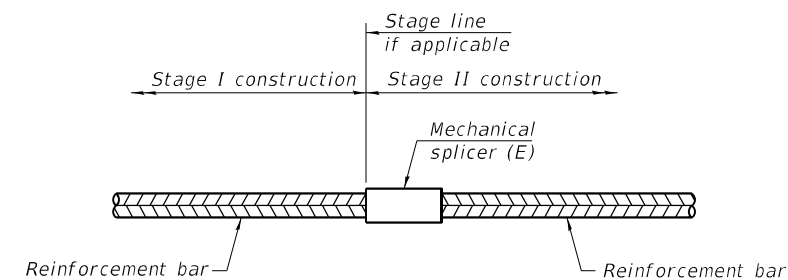

**STANDARD MECHANICAL SPLICER**

Location	Bar size	No. assemblies required

Notes:  
 Splicer bars shall be deformed with threaded ends and have a minimum 60 ksi yield strength.  
 All reinforcement shall be lapped and tied to the splicer bars.  
 Bar splicer assemblies shall be epoxy coated according to the requirements for reinforcement bars. See Section 508 of the Standard Specifications.  
 See approved list of bar splicer assemblies and mechanical splicers for alternatives.

MODEL: BSD  
 FILE NAME: P:\Effingham\3454 - PTB\_189\_IDOT\_D5\_V\Work\_Order\_#6\Cadd\Sheet\178\178\_0178\_0179\_Combined.dgn

BSD-1

1-1-2020



CIVIL DESIGN, INC.  
 WBE / DBE  
 EFFINGHAM, IL  
 LICENSE # 184.003222

USER NAME =	DESIGNED - KAS	REVISED -
	CHECKED - TJZ	REVISED -
PLOT SCALE =	DRAWN - DWS	REVISED -
PLOT DATE =	CHECKED - KAS	REVISED -

STATE OF ILLINOIS  
 DEPARTMENT OF TRANSPORTATION

BAR SPLICER ASSEMBLY AND MECHANICAL SPLICER DETAILS  
 S.N. 057-0178 (SB) & S.N. 057-0179 (NB)

SHEET 13 OF 13 SHEETS

F.A.I. RTE.	SECTION	COUNTY	TOTAL SHEETS	SHEET NO.
55	(57-1,57-2)BDS	MCCLEAN	88	70
			CONTRACT NO. 70D64	
		ILLINOIS FED. AID PROJECT		

Structure 057-0182 was originally constructed in 1973 as FAI 55 over Turkey Creek, Contract 29112, Section 57-2B-2 at Station 711+75.00 in McLean County. In 1998, the structure was reconstructed with Contract 86804, Section (57-2B-2)I. The concrete hatch block was removed and the guardsteel on the approach pavement side was replaced. Existing preformed expansion joint sealer was replaced with silicone joint sealer. Then in 2003, the structure was repaired with Contract 66107, Section (57-1,57-2)RS. The bituminous overlay and waterproofing were removed and the deck was overlaid with 3" of microsilica concrete. The expansion joint seal was replaced at both abutments. Cracks and areas of delamination at the abutments and piers were repaired. Drains within 10' of piers and abutments were plugged and others were extended. Gaps between slopewall and abutment were filled in with CLSM. Loose concrete on underside of deck at the drains was removed and repaired. The approach slabs were removed and replaced. Steel was painted in 2009. The superstructure consists of six 36" wide flange steel plate girders supporting a nominal 8" RC deck with a 3" microsilica concrete overlay. The superstructure is supported by two solid straight stem concrete piers with spread footings on concrete piles and stub abutments on concrete piles. The structure has an overall length of 181'-8" from back to back of abutment. The deck has an out to out width of 42'-0", and a deck (clear area) width of 40'-0" from face to face of parapet and rail. The structure was built on an 18° left-forward skew.

Structure 057-0183 was originally constructed in 1973 as FAI 55 over Turkey Creek, Contract 29112, Section 57-2B-2 at Station 711+75.00 in McLean County. In 2003, the structure was repaired with Contract 66107, Section (57-1,57-2)RS. The bituminous overlay and waterproofing were removed and the deck was overlaid with 3" of microsilica concrete. The west expansion joint was replaced and the east expansion joint seal was replaced. Cracks and areas of delamination at the abutments and piers were repaired. Drains within 10' of piers and abutments were plugged and others were extended. Gaps between slopewall and abutment were filled in with CLSM. Loose concrete on underside of deck at the drains was removed and repaired. The approach slabs were removed and replaced. Steel was painted in 2009. The superstructure consists of six 36" wide flange steel plate girders supporting a nominal 8" RC deck with a 3" microsilica concrete overlay. The superstructure is supported by two solid straight stem concrete piers with spread footings on concrete piles and stub abutments on concrete piles. The structure has an overall length of 181'-8" from back to back of abutment. The deck has an out to out width of 42'-0", and a deck (clear area) width of 40'-0" from face to face of parapet and rail. The structure was built on an 18° left-forward skew.

Traffic Barrier Terminal Type 6 Guardrail (Typ.)  
Remove and Re-erect if needed  
to complete Hydro-demolition

Note:  
See Sheet 2 of 13 for Proposed Work, Bill of  
Material, and General Notes.

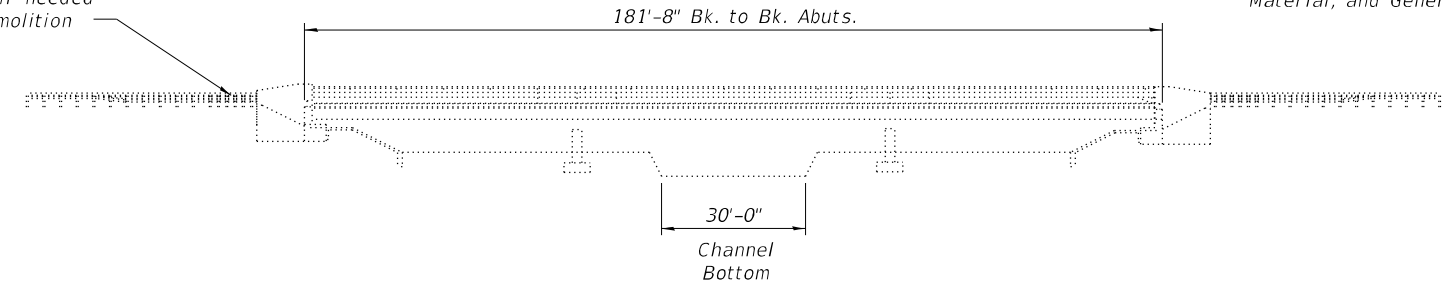

ELEVATION

**DESIGN STRESSES**  
**FIELD UNITS**

New Construction  
f'c = 4,000 psi  
fy = 60,000 psi (Reinforcement)

Existing Structure  
fc = 1,200 psi (Deck Slab)  
fc = 1,400 psi (Curb, Parapet, Sub)  
fs = 20,000 psi (Reinforcement)  
fs = 20,000 psi (Structural Steel)

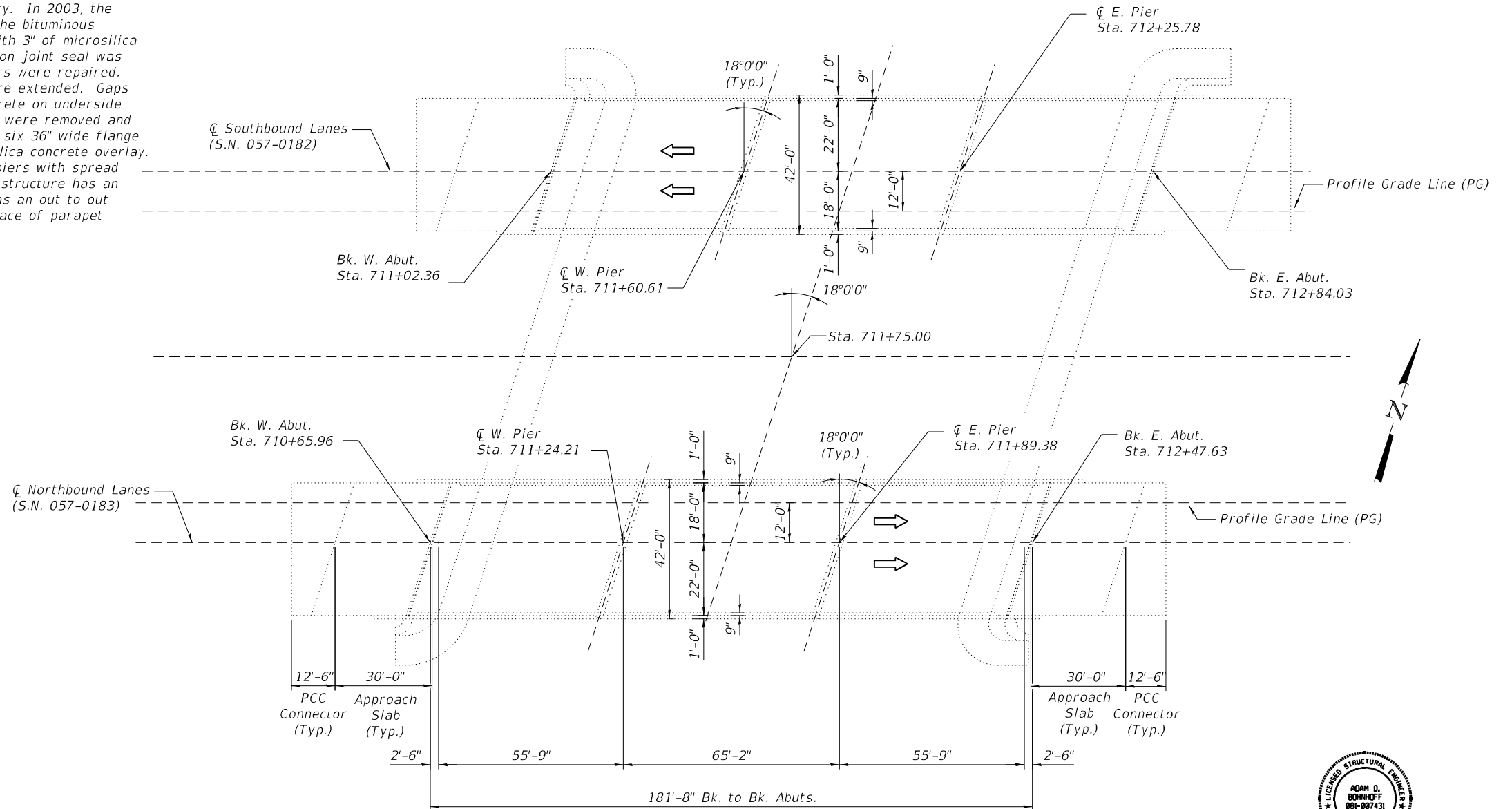
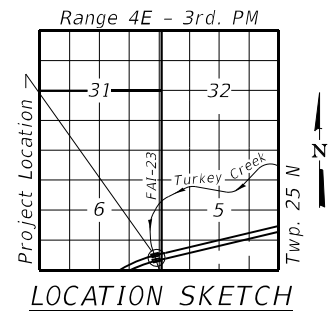

PLAN



Adam Bohnhoff  
Adam D. Bohnhoff  
Licensed Structural Engineer  
State of Illinois No. 081-007431  
Expires 11-30-2022  
10-21-2021  
Date

MODEL: GPE  
FILE NAME: P:\Effingham\3454 - PTB 189 IDOT D5 V-VI\Work Order #6\Cadd\Sheet\183 & 182\0570D64\_0182\_0183\_Combined.dgn  
11/29/2021 1:14:54 PM



USER NAME =	DESIGNED - KAS	REVISED -
PLOT SCALE =	CHECKED - TJZ	REVISED -
PLOT DATE =	DRAWN - DWS	REVISED -
	CHECKED - KAS	REVISED -

STATE OF ILLINOIS  
DEPARTMENT OF TRANSPORTATION

GENERAL PLAN AND ELEVATION  
S.N. 057-0182 (SB) & S.N. 057-0183 (NB)  
SHEET 1 OF 13 SHEETS

F.A.I. RTE.	SECTION	COUNTY	TOTAL SHEETS	SHEET NO.
55	(57-1,57-2)BDS	MCLEAN	88	71
CONTRACT NO. 70D64			ILLINOIS FED. AID PROJECT	



TOTAL BILL OF MATERIAL SN 057-0182 & 057-0183

Item	Unit	Total
Protective Coat	Sq. Yd.	2600
Concrete Removal	Cu. Yd.	40.2
Floor Drains	Each	40
Concrete Superstructure	Cu. Yd.	40.2
Furnishing and Erecting Structural Steel	Pound	6060
Stud Shear Connectors	Each	360
Reinforcement Bars, Epoxy Coated	Pound	1560
Bar Splicers	Each	32
Preformed Joint Strip Seal	Foot	184
Polymer Modified Portland Cement Mortar	Sq. Ft.	1376
Bridge Deck Grooving (Longitudinal)	Sq. Yd.	1404
Bridge Deck Latex Concrete Overlay, 2 1/2"	Sq. Yd.	738
Bridge Deck Latex Concrete Overlay, 3 3/4"	Sq. Yd.	1434
Bridge Deck Scarification, 2"	Sq. Yd.	738
Bridge Deck Scarification, 3 1/2"	Sq. Yd.	1434
Structural Repair of Concrete (Depth = or < 5 Inches)	Sq. Ft.	70
Deck Slab Repair (Full Depth, Type 1)	Sq. Yd.	60
Diamond Grinding (Bridge Section)	Sq. Yd.	2018
Preformed Joint Seal, 1"	Foot	170
Structural Steel Removal	Pound	6060

INDEX OF SHEETS

1. General Plan & Elevation
2. General Data
3. Existing and Proposed Typical Cross Sections
4. Stage Construction Details
5. Wearing Surface Plan
6. Floor Drain and Patching Details
7. Floor Drain Details
8. Superstructure Plan - Concrete Removal Details
9. Superstructure Plan - Deck End Reinforcing
10. Preformed Joint Strip Seal Details
11. Framing Plan
12. Substructure Repair Plan
13. Bar Splicer Assembly and Mechanical Bar Splicer Details

PROPOSED WORK

1. Perform Bridge Deck Scarification on Bridge Deck, Approach Slabs, and PCC Connectors.
2. Partial Removal of Deck Ends and Parapets.
3. Replace Diaphragms at Beam Ends at Abutments.
4. Removal of Existing Joints.
5. Perform Full-Depth Patching and Replacement of Approach Slab Sections.
6. Perform Substructure Repairs.
7. Place New Floor Drains and Perform Polymer Modified Portland Cement Mortar Repair.
8. Pour Deck Ends.
9. Insert Rubber Strip Seal into Locking Edge Rails.
10. Replace Joints at Approach Ends.
11. Pour Parapets.
12. Place Latex Concrete Overlay on Bridge Deck, Approach Slabs, and PCC Connectors.
13. Perform Diamond Grinding and Longitudinal Bridge Deck Grooving.
14. Apply Protective Coat

GENERAL NOTES

Plan dimensions and details relative to the existing structure have been taken from existing plans and are subject to nominal construction variations. It shall be the Contractor's responsibility to verify such dimensions and details in the field and make the necessary approved adjustments prior to construction or ordering of materials. Such variations shall not be cause for additional compensation for a change in the scope of work. However, the Contractor will be paid for the quantity actually furnished at the unit price for the work.

Reinforcement bars designated (E) shall be epoxy coated.

Prior to pouring the new concrete deck, all heavy or loose rust, loose mill scale, and other loose or potentially detrimental foreign material shall be removed from the surfaces in contact with concrete. Tightly adhered paint may remain unless otherwise noted. Removal shall be accomplished by methods that will not damage the steel and the cost will be included in the pay item covering removal of the existing concrete.

Existing structural steel that will be in contact with new structural steel shall be cleaned and painted prior to erection as required by the Special Provision "Cleaning and Painting Contact Surface Areas of Existing Steel Structures".

Existing reinforcement bars extending into the removal area shall be cleaned, straightened and incorporated into the new construction. Any reinforcement bars that are damaged during concrete removal shall be replaced with approved bar splicer or anchorage system. Cost included with Concrete Removal.

Joint openings shall be adjusted according to Article 520.04 of the Std. Specs. when the deck is poured at an ambient temperature other than 50° F.

Up to 1/4" may be ground off the bridge deck and bridge approach slabs through Diamond Grinding.

Expansion joints shall be fabricated and installed according to the manufacturer's recommendations and as approved by the Engineer.

Expansion joints shall be fabricated to conform to the existing cross slopes of the bridge.

Protective Coat shall be applied from end to end of approaches to entire deck surface and along the vertical faces of the parapets.

Synthetic fibers shall be included in the bridge deck concrete overlay specified. See Special Provisions.

MODEL: General Notes  
FILE NAME: P:\Effingham\3454 - PTB 189 IDOT D5 V-V\Work Order #6\Cadd\Sheet\183 & 182\0570D64\_0182\_0183\_Combined.dgn



**CIVIL DESIGN, INC.**  
WBE / DBE  
EFFINGHAM, IL  
LICENSE # 184.003222

USER NAME =	DESIGNED - KAS	REVISED -
	CHECKED - TJZ	REVISED -
PLOT SCALE =	DRAWN - DWS	REVISED -
PLOT DATE =	CHECKED - KAS	REVISED -

**STATE OF ILLINOIS  
DEPARTMENT OF TRANSPORTATION**

**GENERAL DATA  
S.N. 057-0182 (SB) & S.N. 057-0183 (NB)**

SHEET 2 OF 13 SHEETS

F.A.I. RTE.	SECTION	COUNTY	TOTAL SHEETS	SHEET NO.
55	(57-1,57-2)BDS	MCLEAN	88	72
CONTRACT NO. 70D64				
ILLINOIS		FED. AID PROJECT		

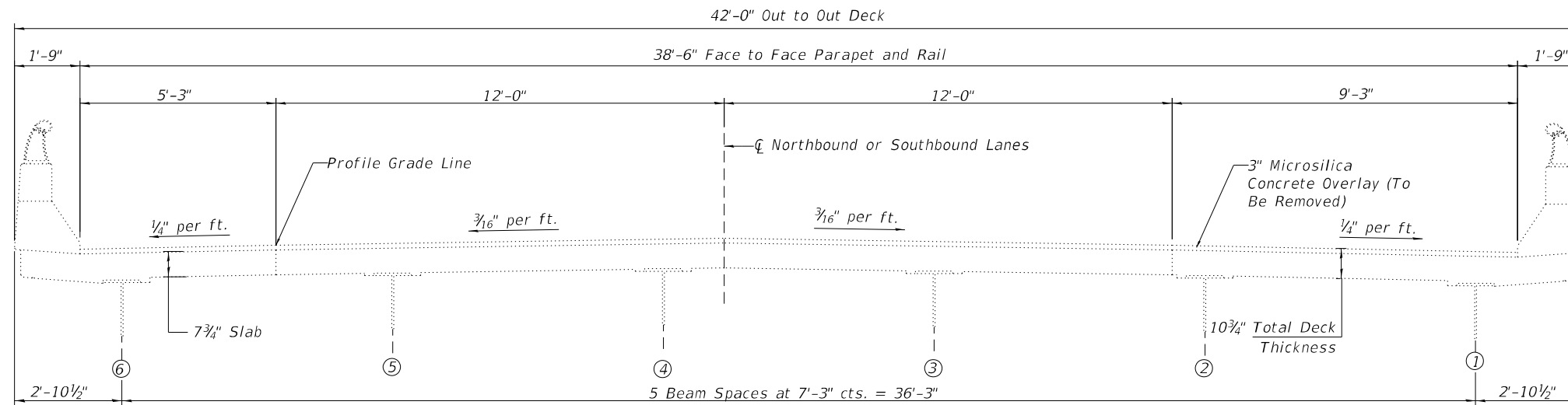

**EXISTING CROSS SECTION**

(S.N. 057-0182 Looking West)  
(S.N. 057-0183 Looking East)

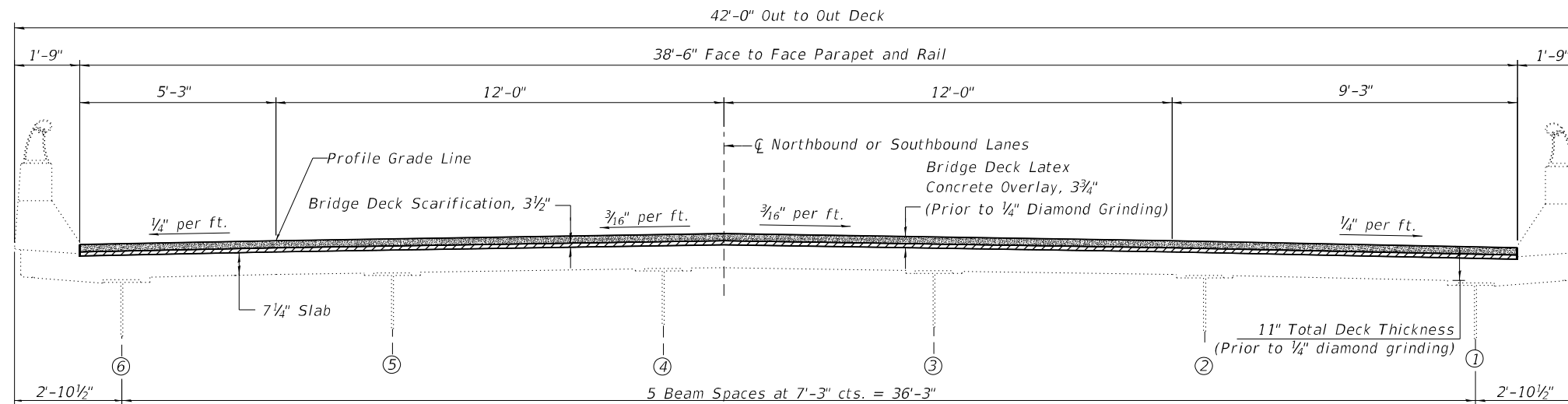

**PROPOSED CROSS SECTION**

(S.N. 057-0182 Looking West)  
(S.N. 057-0183 Looking East)

MODEL: Cross Sections  
FILE NAME: P:\Effingham\3454 - PTB\_189 IDOT D5 V-V\Work Order #6\Cadd\Sheet\183 & 182\182\0183\_0183\_Combined.dgn



CIVIL DESIGN, INC.  
WBE / DBE  
EFFINGHAM, IL  
LICENSE # 184.003222

USER NAME =	DESIGNED - KAS	REVISED -
	CHECKED - TJZ	REVISED -
PLOT SCALE =	DRAWN - DWS	REVISED -
PLOT DATE =	CHECKED - KAS	REVISED -

STATE OF ILLINOIS  
DEPARTMENT OF TRANSPORTATION

EXISTING AND PROPOSED TYPICAL CROSS SECTIONS  
S.N. 057-0182 (SB) & S.N. 057-0183 (NB)

SHEET 3 OF 13 SHEETS

F.A.I. RTE.	SECTION	COUNTY	TOTAL SHEETS	SHEET NO.
55	(57-1,57-2)BDS	MCLEAN	88	73
			CONTRACT NO. 70D64	
		ILLINOIS FED. AID PROJECT		

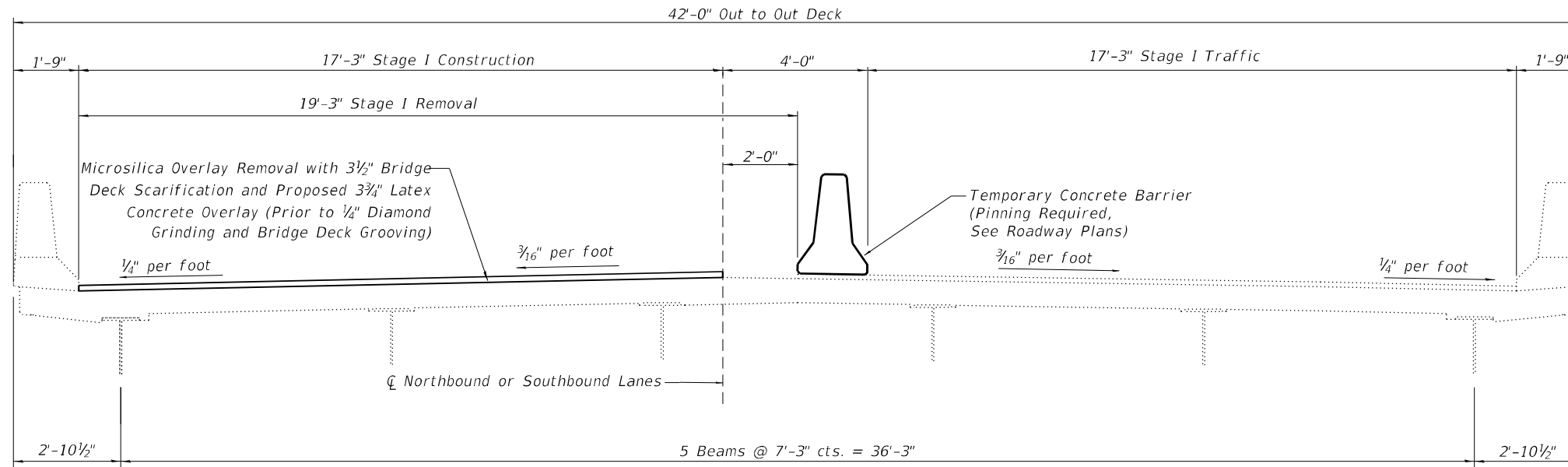

**STAGE I CONSTRUCTION DETAILS**

(S.N. 057-0182 Looking West)  
(S.N. 057-0183 Looking East)

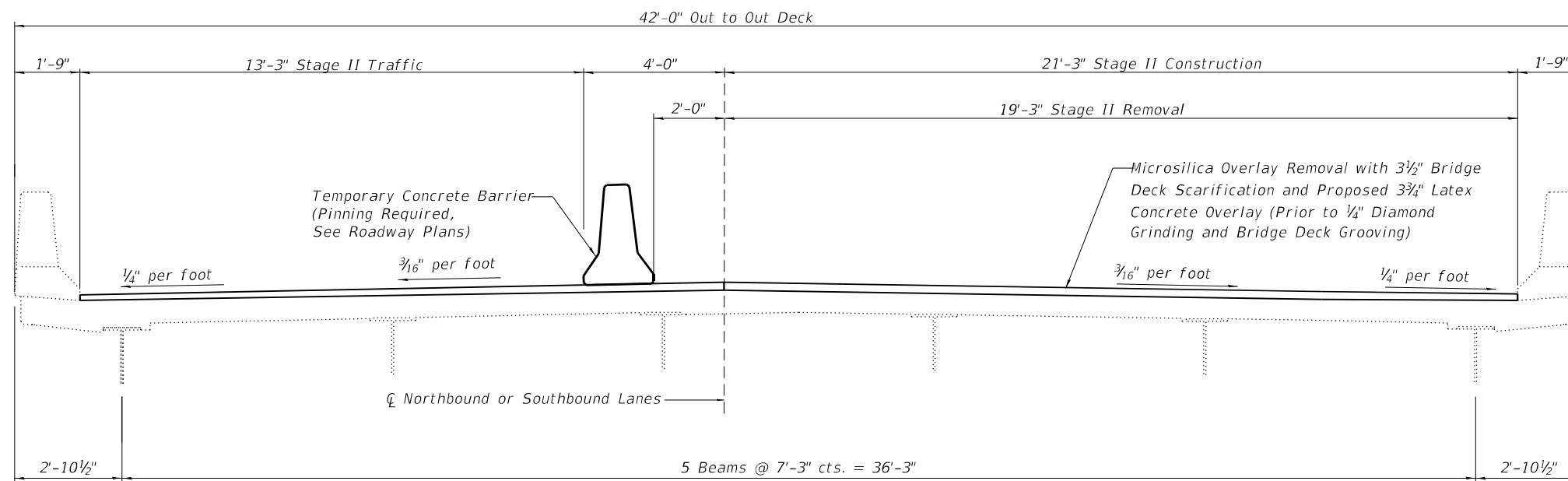

**STAGE II CONSTRUCTION DETAILS**

(S.N. 057-0182 Looking West)  
(S.N. 057-0183 Looking East)

MODEL: Stage Construction  
FILE NAME: P:\Effingham\3454 - PTB 189 IDOT D5 VAVWork Order #6\Cadd\Sheet\183 & 182\0570D64\_0182\_0183\_Combined.dgn



CIVIL DESIGN, INC.  
WBE / DBE  
EFFINGHAM, IL  
LICENSE # 184.003222

USER NAME =	DESIGNED - KAS	REVISED -
	CHECKED - TJZ	REVISED -
PLOT SCALE =	DRAWN - DWS	REVISED -
PLOT DATE =	CHECKED - KAS	REVISED -

STATE OF ILLINOIS  
DEPARTMENT OF TRANSPORTATION

STAGE CONSTRUCTION DETAILS  
S.N. 057-0182 (SB) & S.N. 057-0183 (NB)

SHEET 4 OF 13 SHEETS

F.A.I. RTE.	SECTION	COUNTY	TOTAL SHEETS	SHEET NO.
55	(57-1,57-2)BDS	MCLEAN	88	74
			CONTRACT NO. 70D64	
ILLINOIS FED. AID PROJECT				

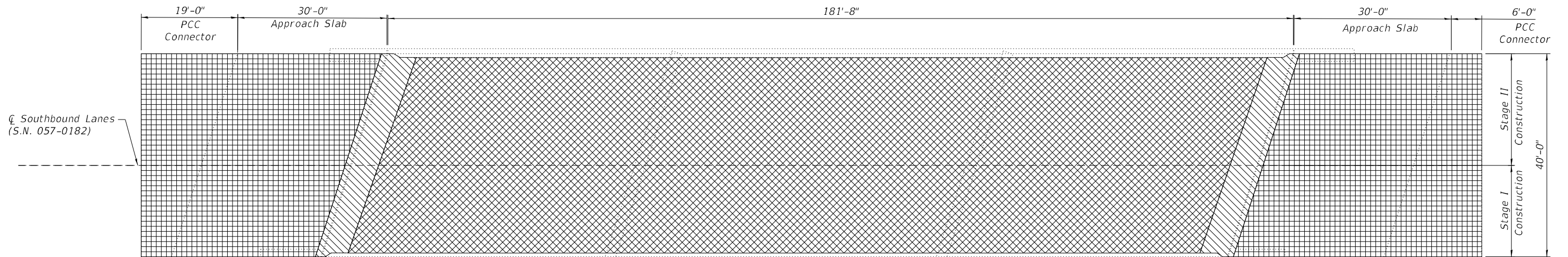

PLAN

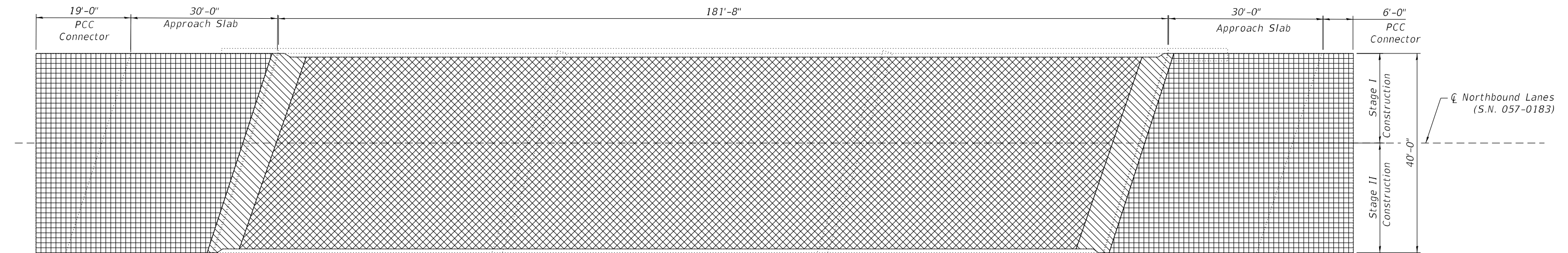

PLAN

**BILL OF MATERIAL**  
(Deck & Approach)

Structure	Item	Unit	Total
057-0182	Bridge Latex Concrete Overlay, 3 3/4"	Sq. Yd.	717
	Bridge Latex Concrete Overlay, 2 1/4"	Sq. Yd.	369
	Bridge Deck Scarification, 3 1/2"	Sq. Yd.	717
	Bridge Deck Scarification, 2"	Sq. Yd.	369
	Bridge Deck Grooving (Longitudinal)	Sq. Yd.	702
057-0183	Diamond Grinding (Bridge Section)	Sq. Yd.	1009
	Bridge Latex Concrete Overlay, 3 3/4"	Sq. Yd.	717
	Bridge Latex Concrete Overlay, 2 1/4"	Sq. Yd.	369
	Bridge Deck Scarification, 3 1/2"	Sq. Yd.	717
	Bridge Deck Scarification, 2"	Sq. Yd.	369
	Bridge Deck Grooving (Longitudinal)	Sq. Yd.	702
	Diamond Grinding (Bridge Section)	Sq. Yd.	1009



Bridge Deck Scarification, 2", Bridge Deck Latex Concrete Overlay, 2 1/4",  
Diamond Grinding, 1/4" and Bridge Deck Grooving (Longitudinal)



Bridge Deck Scarification, 3 1/2", Bridge Latex Concrete Overlay, 3 3/4",  
Diamond Grinding, 1/4" and Bridge Deck Grooving (Longitudinal)



Diamond Grinding, 1/4" and Bridge Deck Grooving (Longitudinal)

MODEL: Wearing Surface  
FILE NAME: P:\Effingham\3454 - PTB\_189\_IDOT\_D5\_VA\Work\_Order\_#6\Cadd\Sheet\183 & 182\0570D64\_0182\_0183\_Combined.dgn



USER NAME =	DESIGNED - KAS	REVISED -
	CHECKED - TJZ	REVISED -
PLOT SCALE =	DRAWN - DWS	REVISED -
PLOT DATE =	CHECKED - KAS	REVISED -

STATE OF ILLINOIS  
DEPARTMENT OF TRANSPORTATION

WEARING SURFACE PLAN  
S.N. 057-0182 (SB) & S.N. 057-0183 (NB)

SHEET 5 OF 13 SHEETS

F.A.I. RTE.	SECTION	COUNTY	TOTAL SHEETS	SHEET NO.
55	(57-1.57-2)BDS	MCLEAN	88	75
			CONTRACT NO. 70D64	
ILLINOIS FED. AID PROJECT				

☐ Southbound Lanes  
(S.N. 057-0182)

☐ Northbound Lanes  
(S.N. 057-0183)

PLAN

PLAN

Replace Preformed Joint Seal  
(Typical all PCC Connectors  
at End Approach Slabs)



**BILL OF MATERIAL**

Structure	Item	Unit	Total
057-0182	Deck Slab Repair (Full Depth, Type 1)	Sq. Yd.	30
057-0182	Polymer Modified Portland Cement Mortar	Sq. Ft.	688
057-0182	Preformed Joint Seal, 1"	Foot	85
057-0183	Deck Slab Repair (Full Depth, Type 1)	Sq. Yd.	30
057-0183	Polymer Modified Portland Cement Mortar	Sq. Ft.	688
057-0183	Preformed Joint Seal, 1"	Foot	85

**NOTES:**



Patch sizes shown represent conditions at the time the plans were completed. An Estimated 2% of the Deck Area has been included should additional Deck Slab Repair (Full Depth, Type 1) be required after Bridge Deck Scarification.

The actual sizes and locations of patching shall be determined by the Resident Engineer after removal of the wearing surface, before patching operations begin. The Engineer Shall show the actual locations of the deck repairs on this sheet.

The existing drains and extensions shall be removed. Cost included with Deck Slab Repair (Full Depth, Type 1).

Extreme care must be used when removing concrete near the top flange of the beams. The Contractor is responsible for any damage to the beams.

**LEGEND**

-  Proposed floor drain location
-  Deck Slab Repair (Full Depth, Type 1) at all Drain Locations. All repair areas are 2'-0" x 1'-1", unless otherwise noted.
-  Polymer Modified Portland Cement Mortar

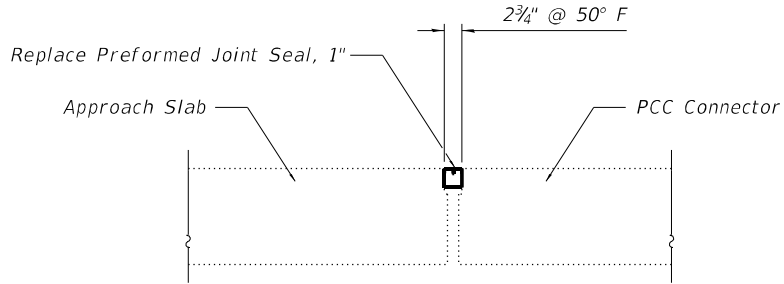

**PREFORMED JOINT REPLACEMENT DETAIL**

(S.N. 057-0182 East & West Approach)  
(S.N. 057-0183 East & West Approach)

MODEL: Patching  
FILE NAME: P:\Effingham\3454 - PTB\_189\_IDOT\_D5\_V-V\Work\_Order\_#6\Cadd\Sheet\183 & 182\0570D64\_0182\_0183\_Combined.dgn  
11/29/2021 1:15:55 PM



USER NAME =	DESIGNED - KAS	REVISED -
	CHECKED - TJZ	REVISED -
PLOT SCALE =	DRAWN - DWS	REVISED -
PLOT DATE =	CHECKED - KAS	REVISED -

**STATE OF ILLINOIS  
DEPARTMENT OF TRANSPORTATION**

**FLOOR DRAIN AND PATCHING DETAILS  
S.N. 057-0182 (SB) & S.N. 057-0183 (NB)**

SHEET 6 OF 13 SHEETS

F.A.I. RTE.	SECTION	COUNTY	TOTAL SHEETS	SHEET NO.
55	(57-1.57-2)BDS	MCLEAN	88	76
			CONTRACT NO. 70D64	
		ILLINOIS FED. AID PROJECT		

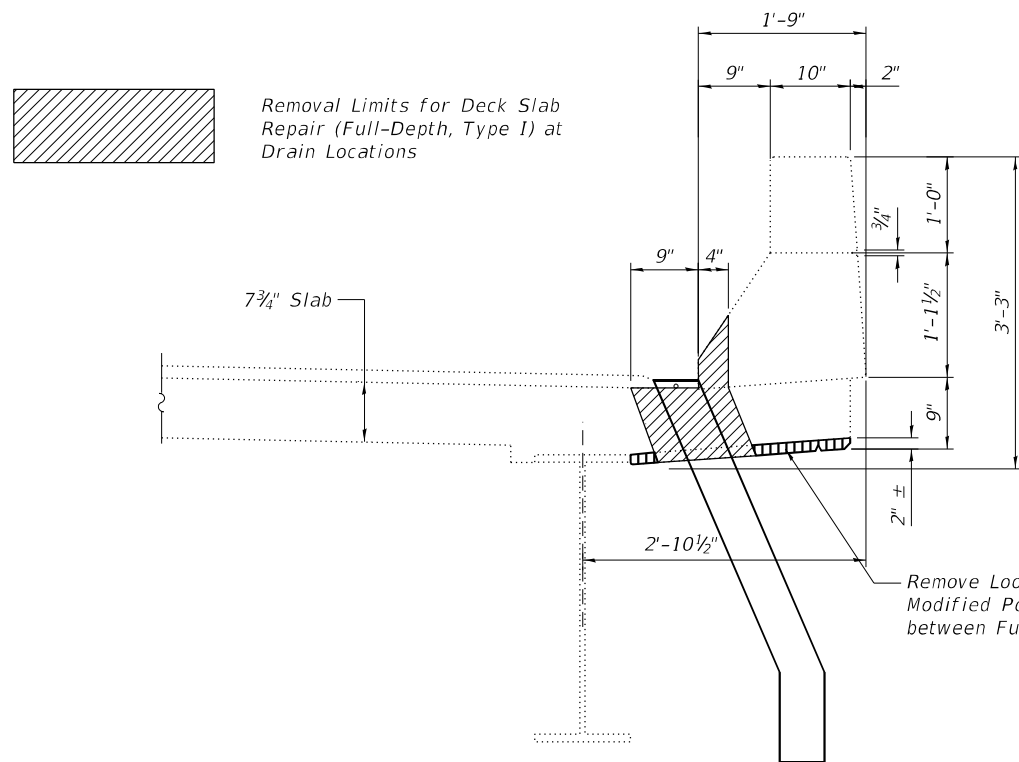

**TYPICAL REMOVAL LIMITS**

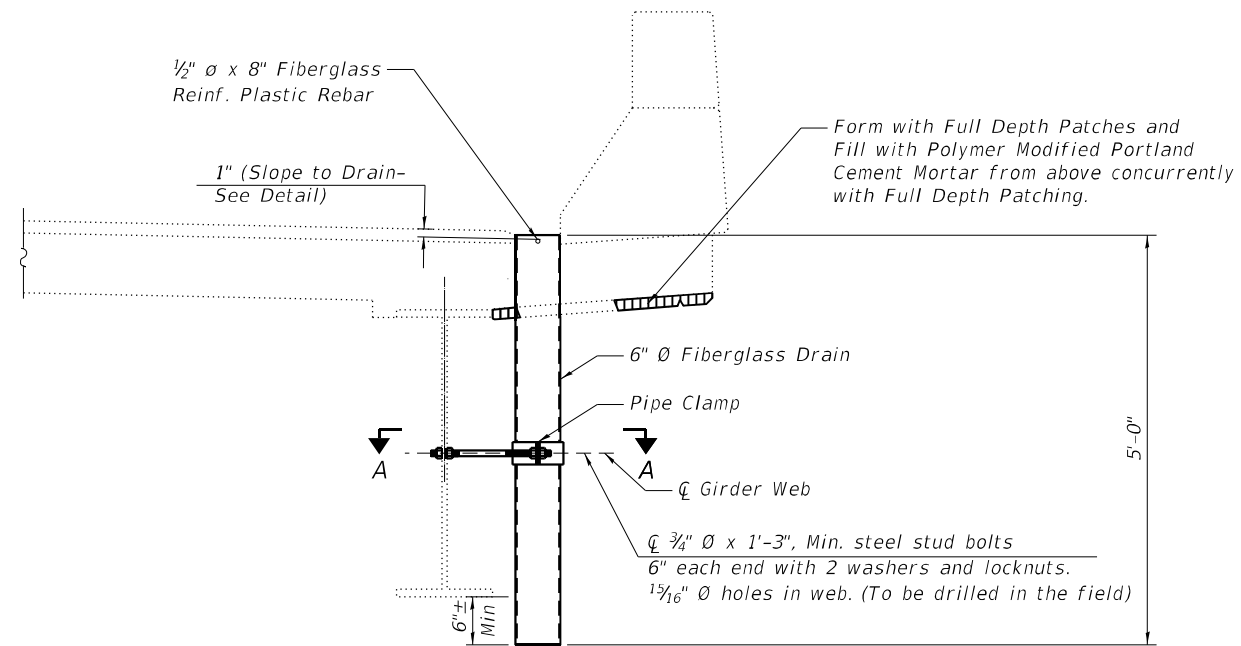

**TYPICAL DRAIN REPLACEMENT**

**Notes:**

All dimensions shall be field verified by the Contractor prior to ordering of materials.

Cost of removal of existing drains and extensions is included in Deck Slab Repair (Full Depth, Type I)

Fiberglass pipe shall conform to ASTM 02996, with short-time rupture strength hoop tensile stress of 30,000 psi minimum.

The exterior surfaces of the floor drains shall be painted according to Article 506 with the finish coat as specified.

The exterior surfaces of the drains shall be cleaned according to the Society of Protective Coating Spec SSPC-SPI prior to painting.

The clamping device shall be galvanized according to AASHTO M 232. Cost of clamping device included with Floor Drains.

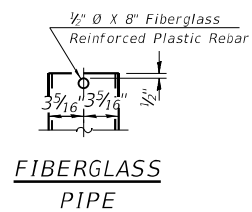

**FIBERGLASS PIPE**

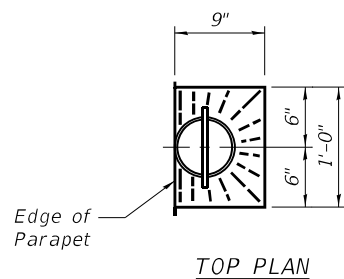

**TOP PLAN**

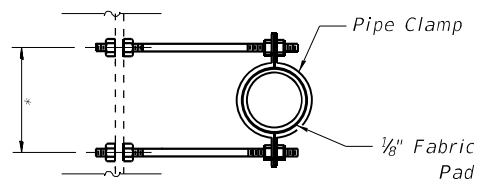

**SECTION A-A**  
\* Dimension as required by Pipe Clamp

**BILL OF MATERIAL**

Structure	Item	Unit	Total
057-0182	Floor Drains	Each	20
057-0183	Floor Drains	Each	20

MODEL: Floor Drain  
FILE NAME: P:\Effingham\3454 - PTB\_189\_IDOT\_D5-V\Work\_Order\_#6\Cadd\Sheet\183 & 182\0570D64\_0182\_0183\_Combined.dgn  
11/29/2021 1:16:21 PM

USER NAME =	DESIGNED - KAS	REVISED -
	CHECKED - TJZ	REVISED -
PLOT SCALE =	DRAWN - DWS	REVISED -
PLOT DATE =	CHECKED - KAS	REVISED -

**STATE OF ILLINOIS  
DEPARTMENT OF TRANSPORTATION**

**FLOOR DRAIN DETAILS  
S.N. 057-0182 (SB) & S.N. 057-0183 (NB)**

SHEET 7 OF 13 SHEETS

F.A.I. RTE.	SECTION	COUNTY	TOTAL SHEETS	SHEET NO.
55	(57-1.57-2)BDS	MCLEAN	88	77
			CONTRACT NO. 70D64	
		ILLINOIS FED. AID PROJECT		

Note: S.N. 057-0182 shown, S.N. 057-0183 similar.

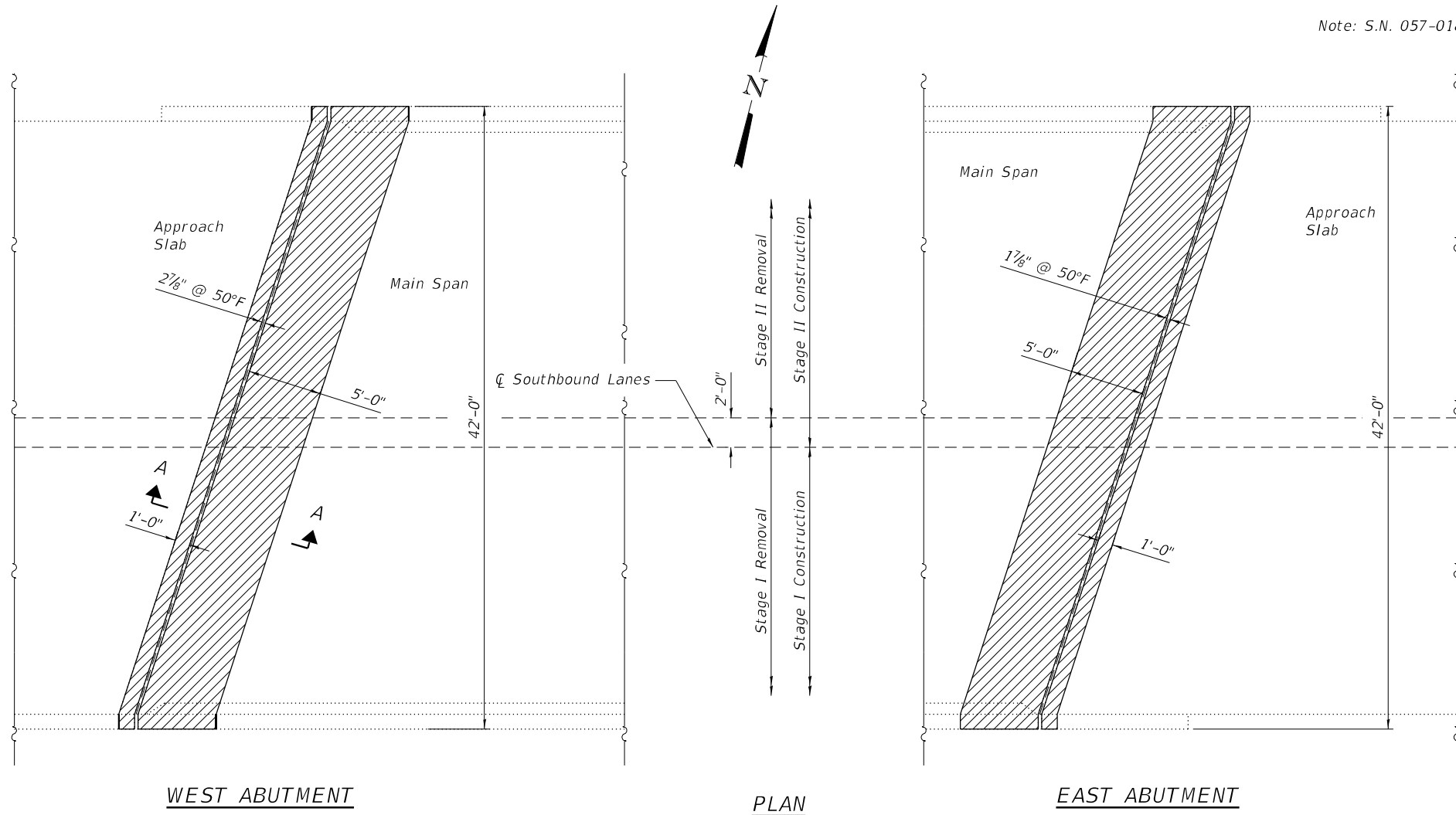

WEST ABUTMENT

PLAN

EAST ABUTMENT

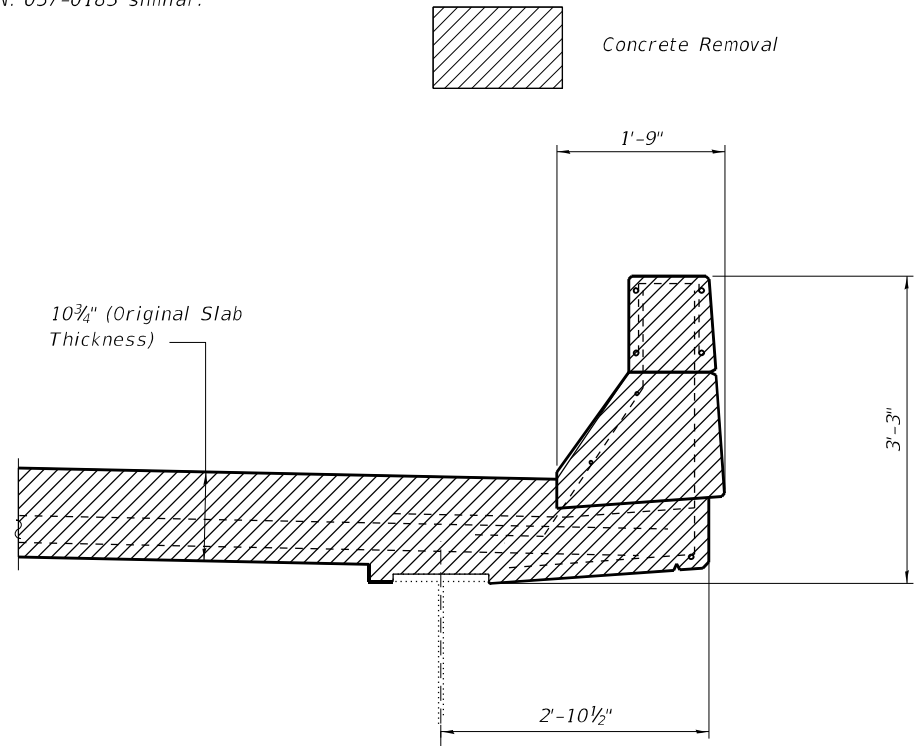

SECTION AT PARAPET

Note: All existing reinforcement to remain in place.

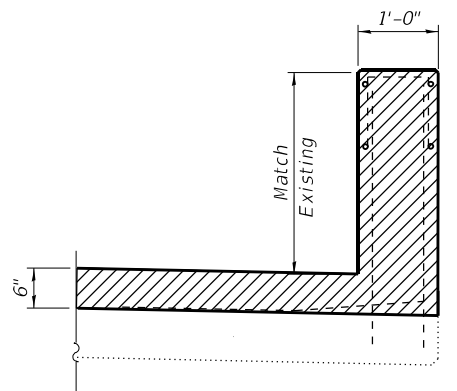

SECTION AT HATCH BLOCK/WING

**NOTES:**

Existing reinforcement bars extending into the removal area shall be cleaned, straightened and incorporated into the New Construction. Any reinforcement bars that are damaged during Concrete Removal shall be replaced with an approved bar splicer or anchorage system. Cost included with Concrete Removal.

The existing expansion joint system shall be removed completely, as well as any foreign material that has accumulated or been placed in the joint openings. The cost for this work is included in Concrete Removal and no additional compensation will be allowed.

The handrail attached to the top of the parapets shall be unbolted to allow for the removal and placement of the parapet ends. Following completion of the parapet ends, the handrail shall be re-attached. The cost of this work shall be included in Concrete Superstructures.

All existing deck tie downs shall be removed. Cost included with Concrete Removal.

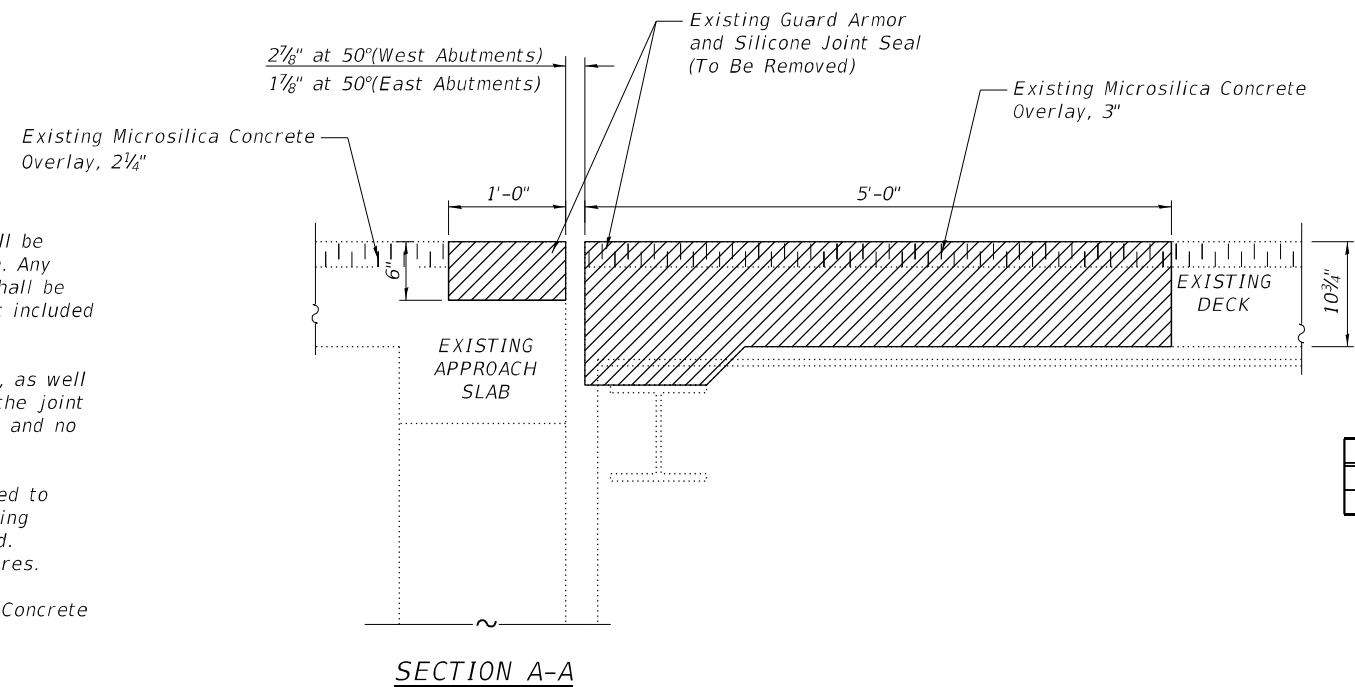

SECTION A-A

**BILL OF MATERIAL**

Structure	Item	Unit	Total
057-0182	Concrete Removal	Cu. Yd.	20.1
057-0183	Concrete Removal	Cu. Yd.	20.1

MODEL: Removal 1  
FILE NAME: P:\Effingham\3454 - PTB 189 IDOT D5 V-VI\Work Order #6\Cadd\Sheet\183 & 182\0570D64\_0182\_0183\_Combined.dgn  
11/29/2021 1:16:45 PM



CIVIL DESIGN, INC.  
WBE / DBE  
EFFINGHAM, IL  
LICENSE # 184.003222

USER NAME =	DESIGNED - KAS	REVISED -
	CHECKED - TJZ	REVISED -
PLOT SCALE =	DRAWN - DWS	REVISED -
PLOT DATE =	CHECKED - KAS	REVISED -

STATE OF ILLINOIS  
DEPARTMENT OF TRANSPORTATION

SUPERSTRUCTURE PLAN - CONCRETE REMOVAL DETAILS  
S.N. 057-0182 (SB) & S.N. 057-0183 (NB)

SHEET 8 OF 13 SHEETS

F.A.I. RTE.	SECTION	COUNTY	TOTAL SHEETS	SHEET NO.
55	(57-1,57-2)BDS	MCLEAN	88	78
			CONTRACT NO. 70D64	
ILLINOIS FED. AID PROJECT				

Note: S.N. 057-0182 shown, S.N. 057-0183 similar.

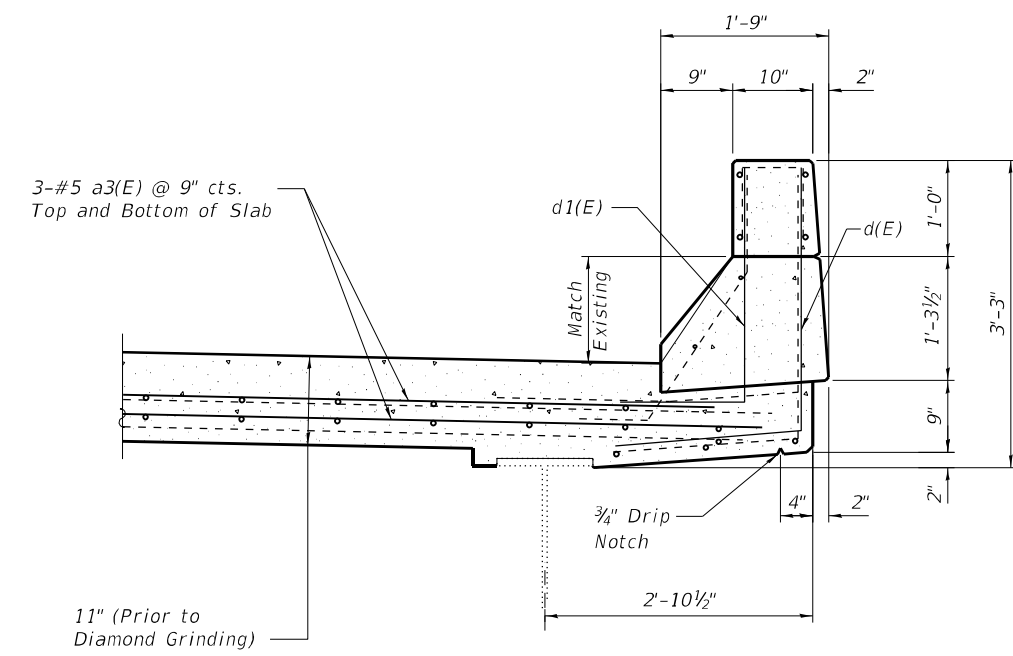
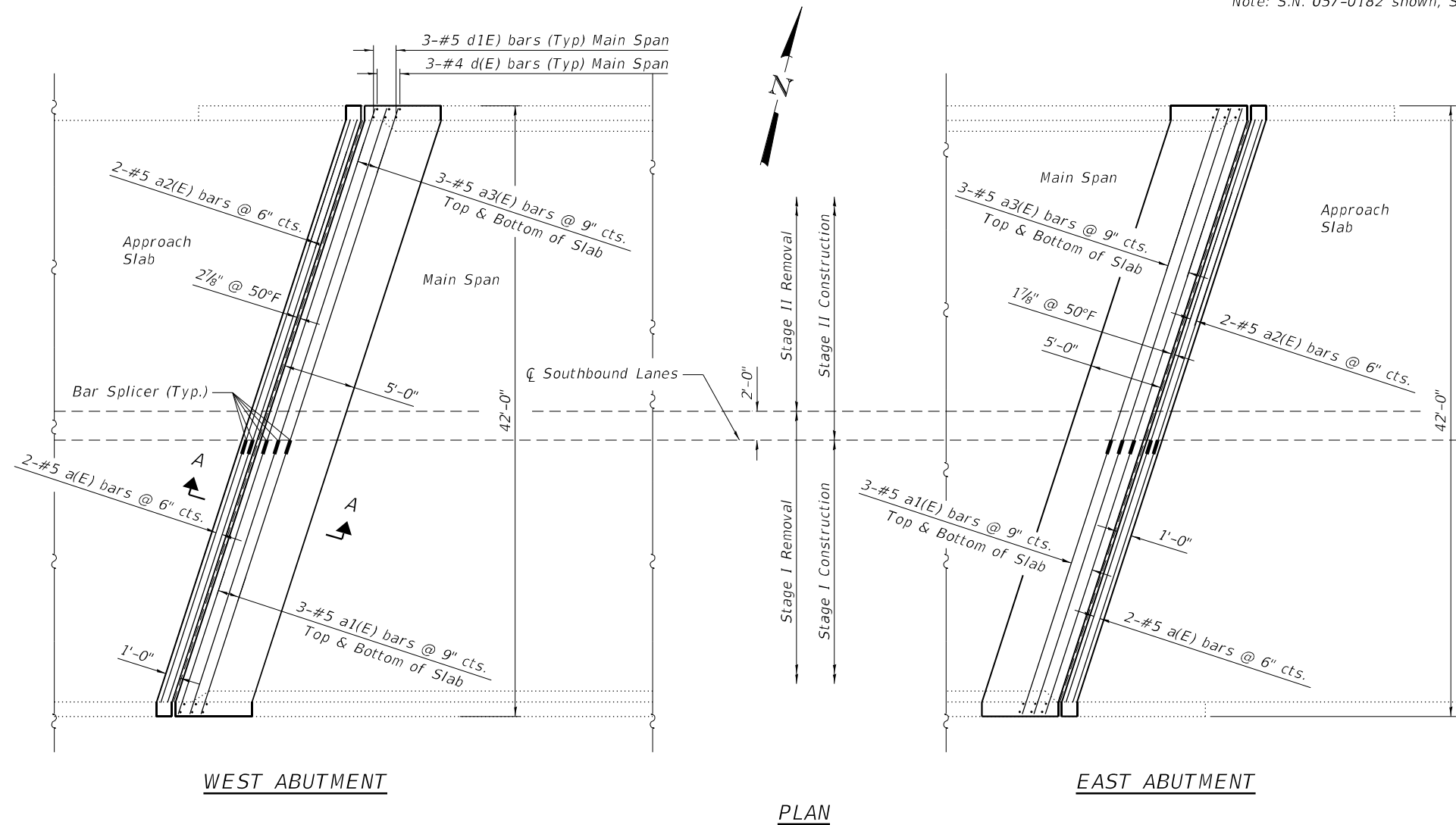

SECTION AT PARAPET  
(Main Span)

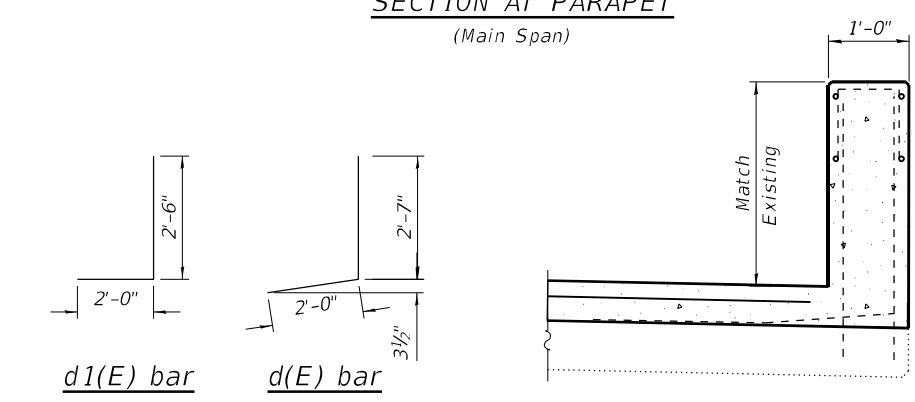

SECTION AT WING

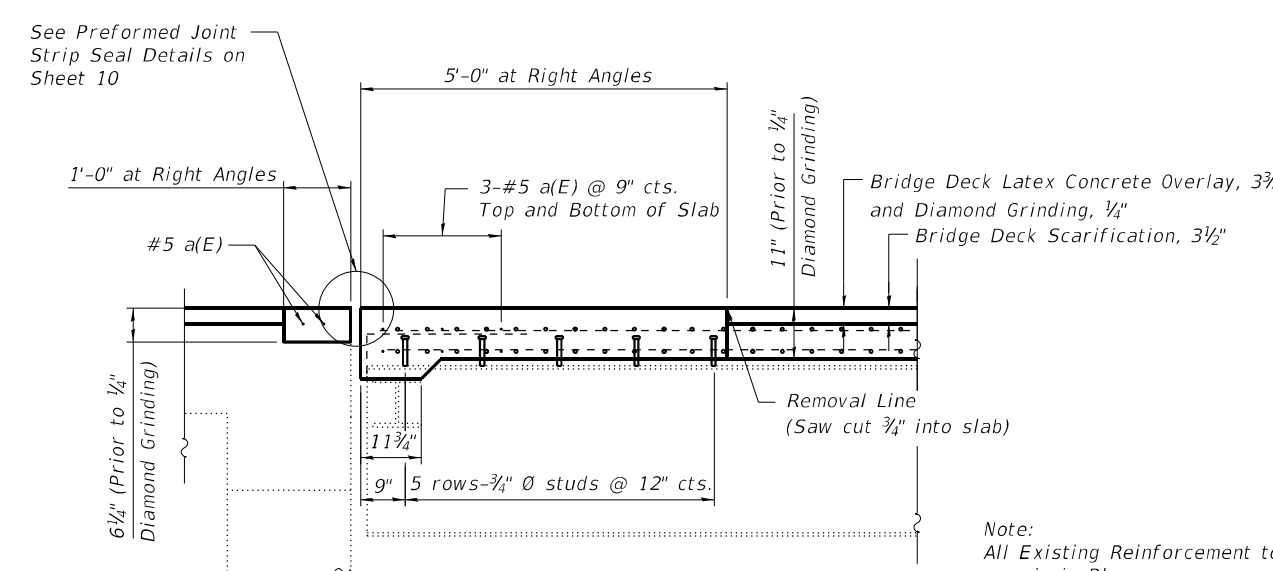

SECTION A-A

Note:  
All Existing Reinforcement to remain in Place.

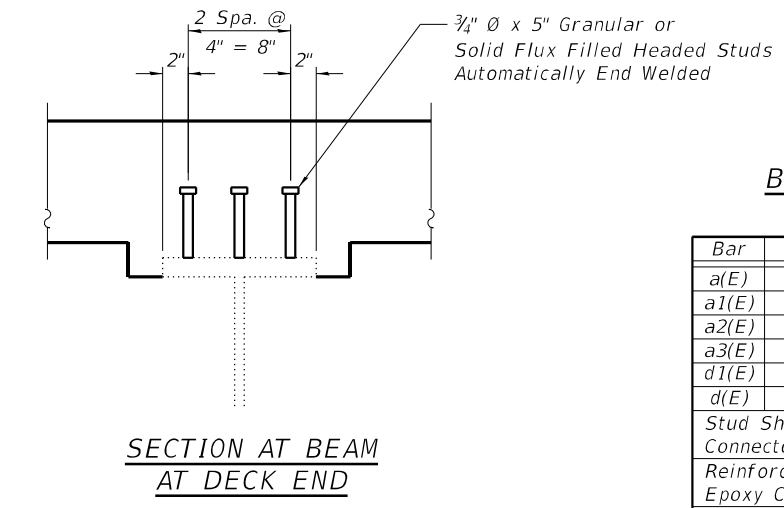

SECTION AT BEAM  
AT DECK END

BILL OF MATERIAL  
(S.N. 057-0182)

Bar	No.	Size	Length	Shape
a(E)	4	#5	18'-3"	—
a1(E)	12	#5	19'-0"	—
a2(E)	4	#5	22'-0"	—
a3(E)	12	#5	22'-2"	—
d1(E)	12	#5	4'-6"	┌
d(E)	12	#4	4'-7"	┌
Stud Shear Connectors			Each	180
Reinforcement Bars, Epoxy Coated			Pound	780
Concrete Superstructure			Cu. Yd.	20.1

BILL OF MATERIAL  
(S.N. 057-0183)

Bar	No.	Size	Length	Shape
a(E)	4	#5	18'-3"	—
a1(E)	12	#5	19'-0"	—
a2(E)	4	#5	22'-0"	—
a3(E)	12	#5	22'-2"	—
d1(E)	12	#5	4'-6"	┌
d(E)	12	#4	4'-7"	┌
Stud Shear Connectors			Each	180
Reinforcement Bars, Epoxy Coated			Pound	780
Concrete Superstructure			Cu. Yd.	20.1

Reinforcement bars designated (E) shall be epoxy coated.

MODEL: Deck End Rebar 1  
FILE NAME: P:\Effingham\3454 - PTB 189 IDOT D5 V-V\Work Order #6\Cadd\Sheet\183 & 182\0570D64\_0182\_0183\_Combined.dgn  
11/29/2021 1:17:08 PM



USER NAME =	DESIGNED - KAS	REVISIONS -
PLOT SCALE =	CHECKED - TJZ	REVISIONS -
PLOT DATE =	DRAWN - DWS	REVISIONS -
	CHECKED - KAS	REVISIONS -

STATE OF ILLINOIS  
DEPARTMENT OF TRANSPORTATION

SUPERSTRUCTURE PLAN - DECK END REINFORCING  
S.N. 057-0182 (SB) & S.N. 057-0183 (NB)

F.A.I. RTE.	SECTION	COUNTY	TOTAL SHEETS	SHEET NO.
55	(57-1.57-2)BDS	MCLEAN	88	79
CONTRACT NO. 70D64				
ILLINOIS FED. AID PROJECT				



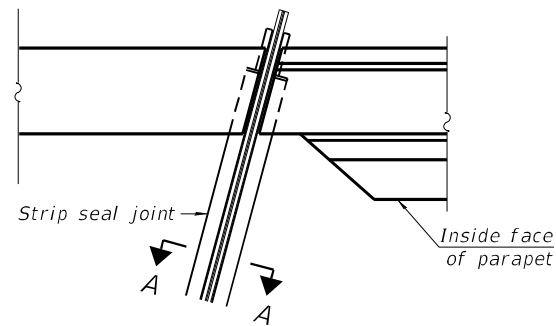

PLAN AT PARAPET

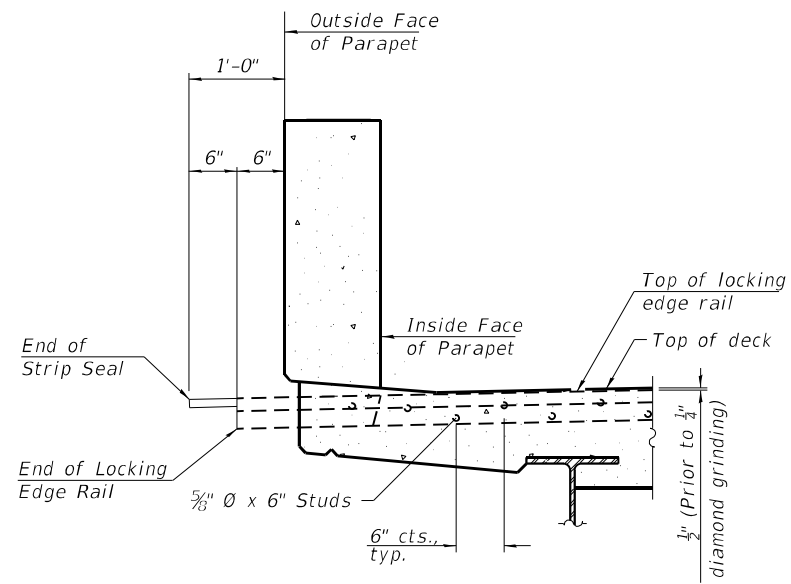

ELEVATION AT PARAPET

Notes:  
 The strip seal shall be made continuous and shall have a minimum thickness of 1/4". The configuration of the strip seal shall match the configuration of the locking edge rails. Open or "webbed" strip seal gland configurations are not permitted. The gland shall be sized for a maximum rated movement of 4 inches.  
 The locking edge rails depicted are configured for typical applications and are conceptual only. The actual configuration of the locking edge rails and matching strip seal may vary from manufacturer to manufacturer provided they fit the application and meet the minimum anchorage shown. Flanged edge rails, however, will not be allowed. Locking edge rails may exceed the 4 1/2" maximum depth provided the anchorage system is revised according to the manufacturer's recommendation.  
 The manufacturer's recommended installation methods shall be followed.

All steel components shall be galvanized after fabrication according to Article 520.03 of the Standard Specifications.  
 The Maximum space between locking edge rail segments shall be 3/16" and sealed with a suitable sealant; however, any rail joint within 10' measured perpendicular to the face of the curb or parapet shall be welded as shown in the locking edge rail splice detail.

The concrete opening below the strip seal will vary based on the locking edge rail chosen by the Contractor. Deck and parapet lengths shown elsewhere in the plans are dimensioned to the concrete opening, not the joint opening, and are based on the rolled locking edge rail. If the Contractor elects to use a different locking edge rail, dimensional adjustments may be required. One exception to this would be the strip seal joint at the end of the precast bridge approach slab. For these cases the pavement connector length shall be adjusted, not the length of the bridge approach slab.

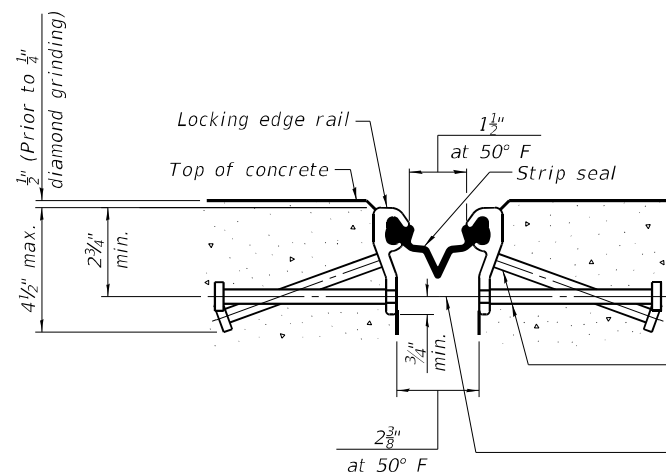

SHOWING ROLLED RAIL JOINT

\* 5/8"  $\phi$  x 6" studs @ 6" cts. (alternate angled/bent studs with horizontal studs)  
 3/8"  $\phi$  threaded rods in 1/16"  $\phi$  holes at  $\pm 4'-0"$  cts. for holding the proper joint opening based on the temperature during the deck pour. Place to miss studs. All rods shall be burned, or sawed off flush with the plates after concrete is set.

SECTION A-A

\* Granular or solid flux filled headed studs conforming to Article 1006.32 of the Std. Specs., automatically end welded.

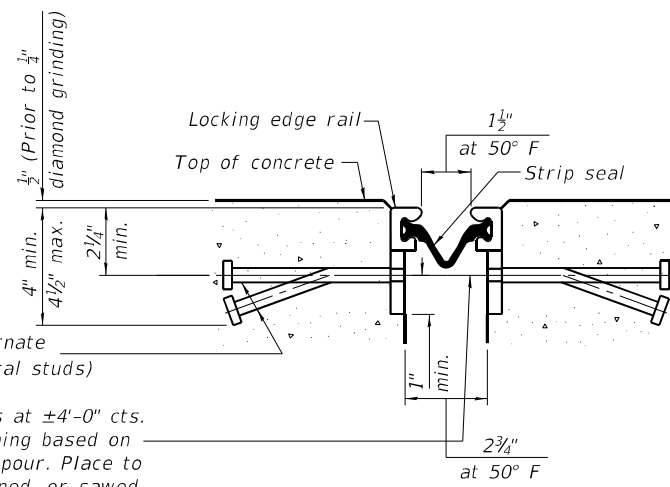

SHOWING WELDED RAIL JOINT

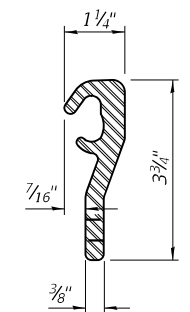

ROLLED (EXTRUDED) RAIL

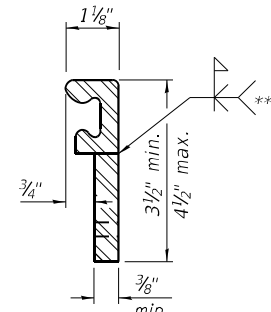

WELDED RAIL

LOCKING EDGE RAILS

\*\* Back gouge not required if complete joint penetration is verified by mock-up.

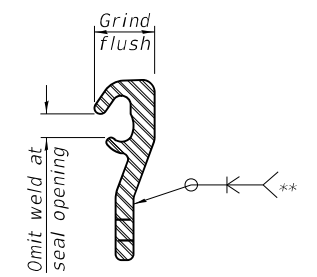

LOCKING EDGE RAIL SPLICE

The inside of the locking edge rail groove shall be free of weld residue. Rolled rail shown, welded rail similar.

BILL OF MATERIAL

Structure	Item	Unit	Total
057-0182	Preformed Joint Strip Seal	Foot	92
057-0183	Preformed Joint Strip Seal	Foot	92

MODEL: Joint Strip Seal  
 FILE NAME: P:\Effingham\3454 - PTB\_189\_IDOT D5 V-V\Work Order #6\Cadd\Sheet\183 & 182\0570D64\_0182\_0183\_Combined.dgn

**CDI**  
 CIVIL DESIGN, INC.  
 WBE / DBE  
 EFFINGHAM, IL  
 LICENSE #184.003222

USER NAME =	DESIGNED - KAS	REVISED -
PLOT SCALE =	CHECKED - TJZ	REVISED -
PLOT DATE =	DRAWN - DWS	REVISED -
	CHECKED - KAS	REVISED -

STATE OF ILLINOIS  
 DEPARTMENT OF TRANSPORTATION

PREFORMED JOINT STRIP SEAL DETAILS  
 S.N. 057-0182 (SB) & S.N. 057-0183 (NB)

F.A.I. RTE.	SECTION	COUNTY	TOTAL SHEETS	SHEET NO.
55	(57-1,57-2)BDS	MCLEAN	88	80
			CONTRACT NO. 70D64	
ILLINOIS			FED. AID PROJECT	

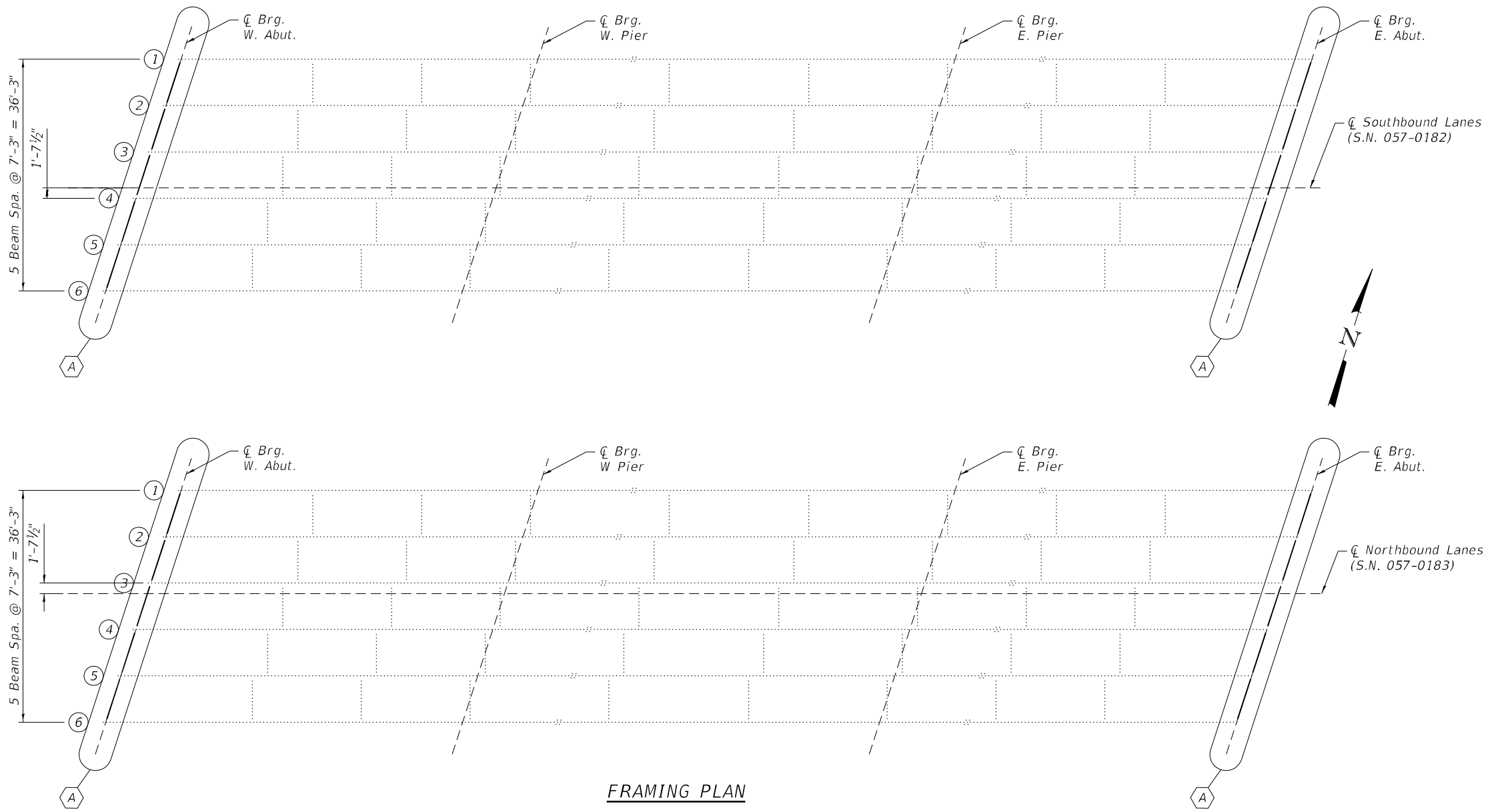

**FRAMING PLAN**

A Diaphragm Replacement

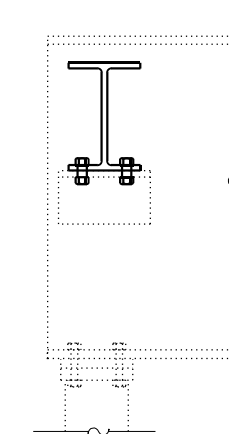

**SECTION B-B**

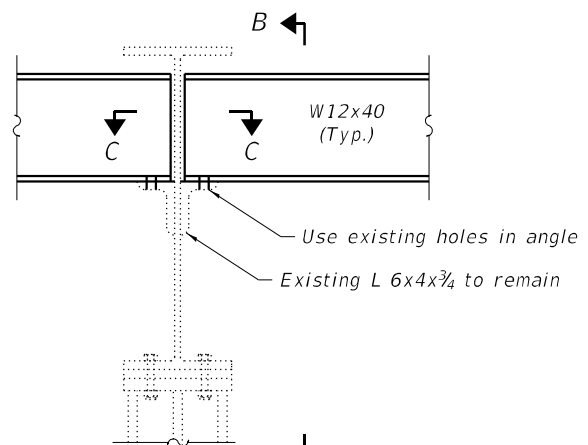

**ELEVATION**

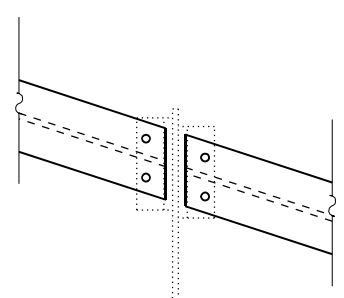

**SECTION C-C**

**NOTES:**

All structural steel shall conform to AASHTO Classification M-270 GR. 36, unless otherwise noted.

Fasteners shall be high strength bolts. Bolts 3/4"Ø, open holes 13/16"Ø, unless otherwise noted.

Diaphragm connection holes shall be 13/16"Ø for 3/4"Ø bolts. Two hardened washers shall be required at diaphragm connections.

Plan dimensions and details relative to existing plans are subject to nominal construction variations. The Contractor shall field verify existing dimensions and details affecting new construction and make necessary approved adjustments prior to construction or ordering of materials. Such variations shall not be cause for additional compensation for a change in scope of the work, however, the Contractor will be paid for the quantity actually furnished at the unit price bid for the work.

Existing structural steel that will be in contact with new structural steel shall be cleaned and painted prior to erection as required by the GBSP "Cleaning and Painting Contact Surface Areas of Existing Steel Structures".

All structural steel shall be hot-dip galvanized. See Special Provisions for "Hot Dip Galvanizing For Structural Steel".

Cost of removal and re-installation of all members necessary to complete the work as detailed on the plans and as specified in the Special Provisions shall be included with Furnishing and Erecting Structural Steel.

**BILL OF MATERIAL**

Structure	Item	Unit	Total
057-0182	Furnishing and Erecting Structural Steel	Pound	3030
	Structural Steel Removal	Pound	3030
057-0183	Furnishing and Erecting Structural Steel	Pound	3030
	Structural Steel Removal	Pound	3030

MODEL: Framing  
FILE NAME: P:\Effingham\3454 - PTB\_189\_IDOT\_D5-V\Work\_Order\_#6\Cadd\Sheet\183 & 182\0570D64\_0182\_0183\_Combined.dgn  
12/7/2021 6:18:40 PM



USER NAME =	DESIGNED - KAS	REVISED -
PLOT SCALE =	CHECKED - TJZ	REVISED -
PLOT DATE =	DRAWN - DWS	REVISED -
	CHECKED - KAS	REVISED -

**STATE OF ILLINOIS  
DEPARTMENT OF TRANSPORTATION**

**FRAMING PLAN  
S.N. 057-0182 (SB) & S.N. 057-0183 (NB)**

SHEET 11 OF 13 SHEETS

F.A.I. RTE.	SECTION	COUNTY	TOTAL SHEETS	SHEET NO.
55	(57-1,57-2)BD5	MCLEAN	88	81
			CONTRACT NO. 70D64	
		ILLINOIS FED. AID PROJECT		

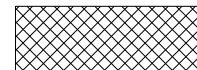

Structural Repair of Concrete  
Depth equal to or Less than 5"

**Note:**

See Special Provision for Structural Repair of Concrete.

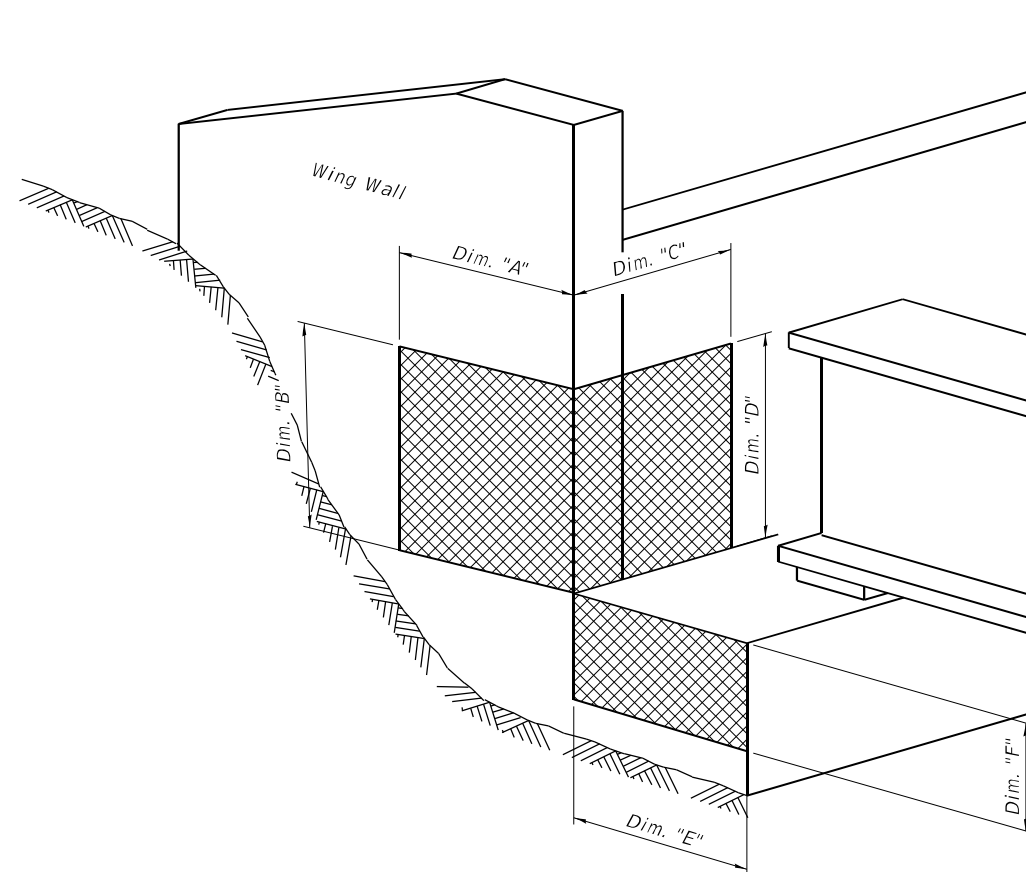

ISOMETRIC VIEW AT ABUTMENT CORNER

S.N. 057-0182  
TABLE FOR STRUCTURAL REPAIR OF CONCRETE

ABUTMENT CORNER	Repair Area Dimensions						Repair Area Sq. Ft.
	Wingwall		Backwall		Abutment Seat		
	A	B	C	D	E	F	
Northeast	2	2	-	-	-	-	4
Southeast	1	2	1	1	-	-	3
Northwest	1	3	-	-	-	-	3
Southwest	3	4	-	-	-	-	12

S.N. 057-0183  
TABLE FOR STRUCTURAL REPAIR OF CONCRETE

ABUTMENT CORNER	Repair Area Dimensions						Repair Area Sq. Ft.
	Wingwall		Backwall		Abutment Seat		
	A	B	C	D	E	F	
Northeast	2	3	3	4	-	-	18
Southeast	2	1	2	3	-	-	8
Northwest	3	3	2	4	-	-	17
Southwest	2	2	1	1	-	-	5

BILL OF MATERIAL

Structure	Item	Unit	Total
057-0182	Structural Repair of Concrete, Depth Equal to or Less than 5"	Sq. Ft.	22
057-0183	Structural Repair of Concrete, Depth Equal to or less than 5"	Sq. Ft.	48

MODEL: Sub Repairs  
FILE NAME: P:\Effingham\3454 - PTB\_189\_IDOT\_D5\_V\Work\_Order\_#6\Cadd\Sheet\183 & 182\0570D64\_0182\_0183\_Combined.dgn



CIVIL DESIGN, INC.  
WBE / DBE  
EFFINGHAM, IL  
LICENSE # 184.003222

USER NAME =	DESIGNED - KAS	REVISED -
	CHECKED - TJZ	REVISED -
PLOT SCALE =	DRAWN - DWS	REVISED -
PLOT DATE =	CHECKED - KAS	REVISED -

STATE OF ILLINOIS  
DEPARTMENT OF TRANSPORTATION

SUBSTRUCTURE REPAIR PLAN  
S.N. 057-0182 (SB) & S.N. 057-0183 (NB)

SHEET 12 OF 13 SHEETS

F.A.I. RTE.	SECTION	COUNTY	TOTAL SHEETS	SHEET NO.
55	(57-1.57-2)BDS	MCLEAN	88	82
			CONTRACT NO. 70D64	
ILLINOIS FED. AID PROJECT				

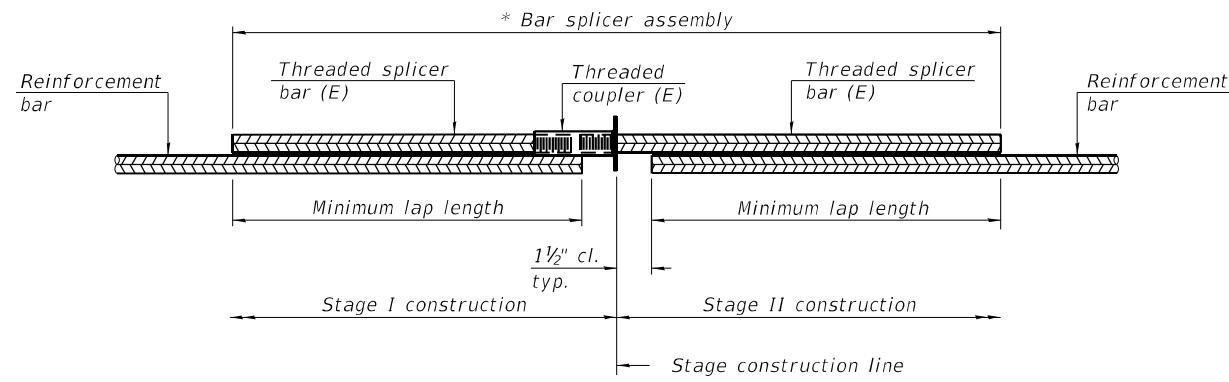

**STANDARD BAR SPLICER ASSEMBLY PLAN**  
 (All components shall be provided from one supplier)

Threaded splicer bar length = min. lap length + 1 1/2" + thread length

\* Epoxy not required on Bar Splicer Assembly components used in conjunction with black bars.

Structure	Location	Bar size	No. assemblies required	Minimum lap length
057-0182	Deck End	#5	16	3'-6"
057-0183	Deck End	#5	16	3'-6"

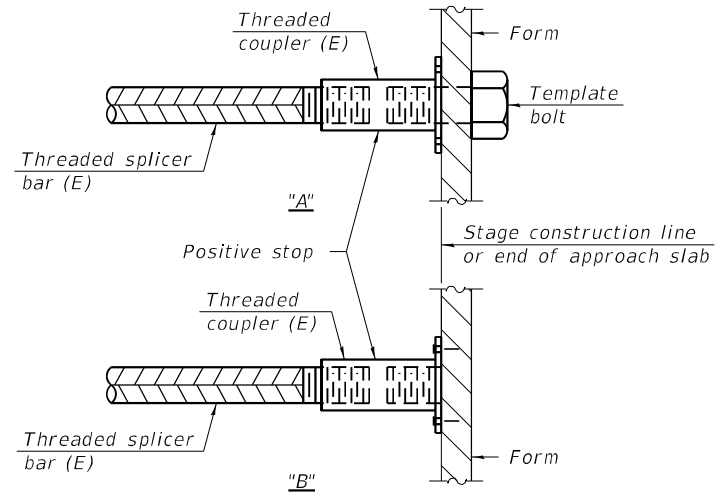

**INSTALLATION AND SETTING METHODS**

"A" : Set bar splicer assembly by means of a template bolt.  
 "B" : Set bar splicer assembly by nailing to wood forms or cementing to steel forms.  
 (E) : Indicates epoxy coating.

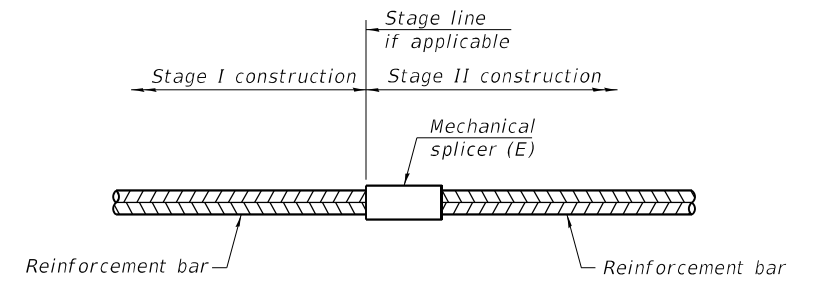

**STANDARD MECHANICAL SPLICER**

Location	Bar size	No. assemblies required

Notes:  
 Splicer bars shall be deformed with threaded ends and have a minimum 60 ksi yield strength.  
 All reinforcement shall be lapped and tied to the splicer bars.  
 Bar splicer assemblies shall be epoxy coated according to the requirements for reinforcement bars. See Section 508 of the Standard Specifications.  
 See approved list of bar splicer assemblies and mechanical splicers for alternatives.

MODEL: BSD  
 FILE NAME: P:\Effingham\3454 - PTB 189 IDOT D5 V-V\Work Order #6\Cadd\Sheet\183 & 182\0570D64\_0182\_0183\_Combined.dgn

BSD-1

1-1-2020



CIVIL DESIGN, INC.  
 WBE / DBE  
 EFFINGHAM, IL  
 LICENSE # 184.003222

USER NAME =	DESIGNED - KAS	REVISED -
	CHECKED - TJZ	REVISED -
PLOT SCALE =	DRAWN - DWS	REVISED -
PLOT DATE =	CHECKED - KAS	REVISED -

STATE OF ILLINOIS  
 DEPARTMENT OF TRANSPORTATION

BAR SPLICER ASSEMBLY AND MECHANICAL SPLICER DETAILS  
 S.N. 057-0182 (SB) & S.N. 057-0183 (NB)

SHEET 13 OF 13 SHEETS

F.A.I. RTE.	SECTION	COUNTY	TOTAL SHEETS	SHEET NO.
55	(57-1,57-2)BDS	MCLEAN	88	83
			CONTRACT NO. 70D64	
		ILLINOIS FED. AID PROJECT		

11/29/2021 1:18:14 PM

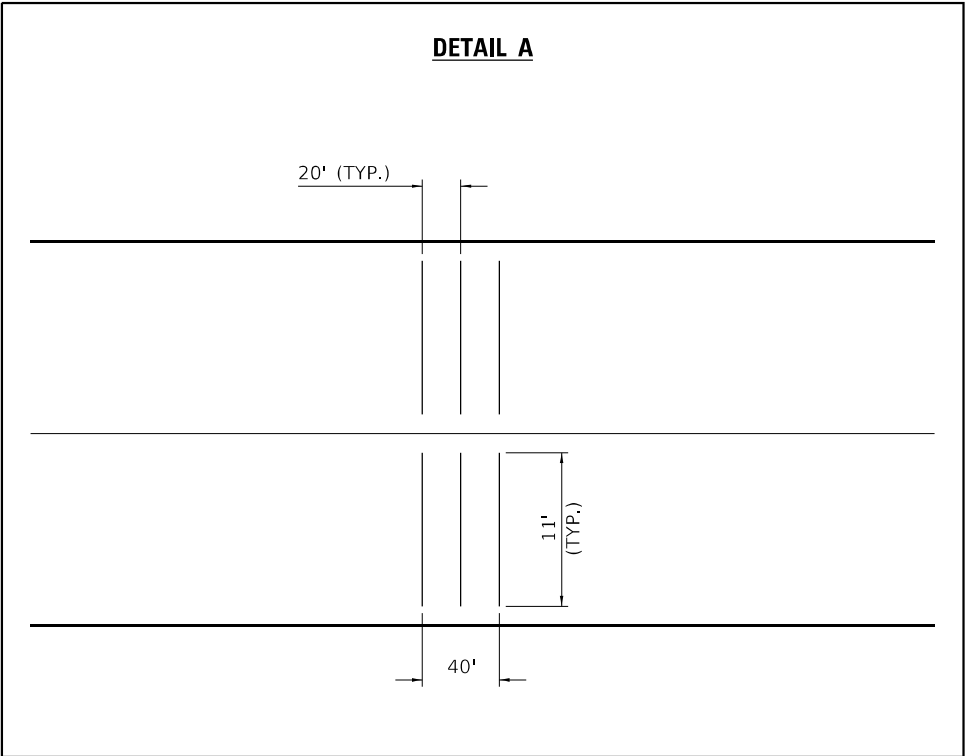
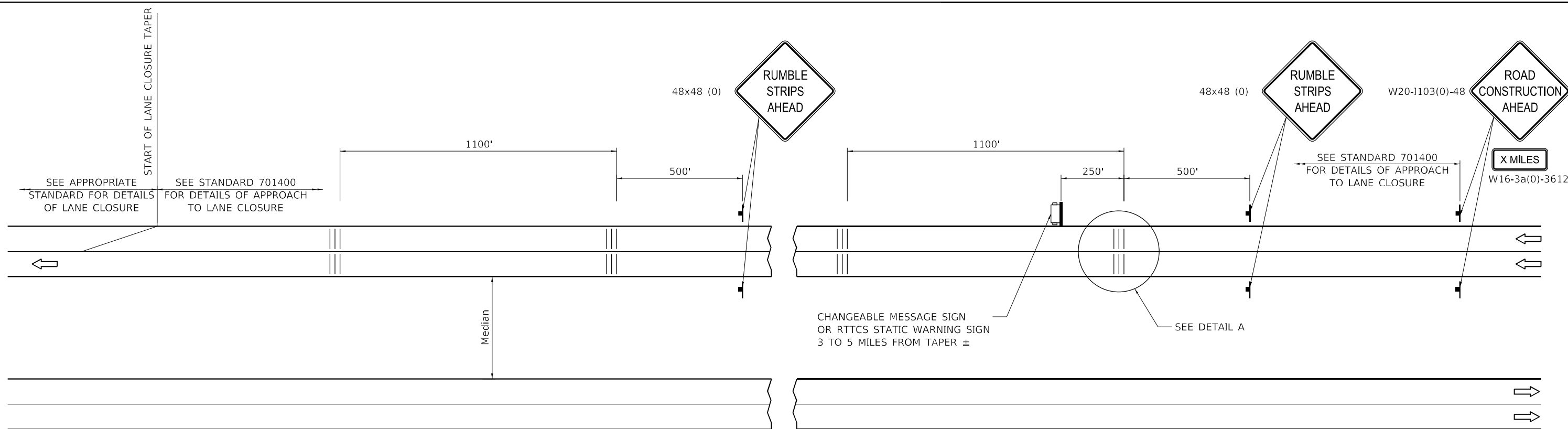

**SYMBOLS**

- SIGN
- TEMPORARY RUMBLE STRIPS (SPECIAL)
- TRAILER MOUNTED SIGN
- RTTCS STATIC WARNING SIGN

**GENERAL NOTES**

REMOVE THE TEMPORARY RUMBLE STRIPS (SPECIAL) PRIOR TO THE REMOVAL OF THE ADVANCED WARNING SIGNS.

ALL DIMENSIONS ARE IN INCHES UNLESS OTHERWISE SHOWN.

PLACE TEMPORARY RUMBLE STRIPS PRIOR TO ANY WORK AREA LANE CLOSURES.

MODEL: D:\p\h\...  
 FILE NAME: P:\Effingham\70664.ctb  
 Order #6/Cadd/Sheet/70664.ctb  
 Details: Temp\_Rumble.dgn

CIVIL DESIGN, INC.  
 WBE / DBE  
 EFFINGHAM, IL  
 LICENSE # 184.003222

USER NAME = rhanland	DESIGNED - WMK	REVISED -
DRAWN - DMM	REVISOR -	
PLOT SCALE = 40,0000' / in.	CHECKED - RLH	REVISED -
PLOT DATE = 10/21/2021	DATE - 10/21/2021	REVISED -

STATE OF ILLINOIS  
DEPARTMENT OF TRANSPORTATION

TEMPORARY RUMBLE STRIPS (SPECIAL)			
SCALE: N.T.S.	SHEET 1 OF 1 SHEETS	STA.	TO STA.

F.A.I. RTE.	SECTION	COUNTY	TOTAL SHEETS	SHEET NO.
55	(57-1,57-2)BD5	MCLEAN	88	84
CONTRACT NO. 70D64				
ILLINOIS FED. AID PROJECT				

**CENTERLINE INTERSTATE OR MULTI-LANE TWO WAY DIVIDED HIGHWAY**

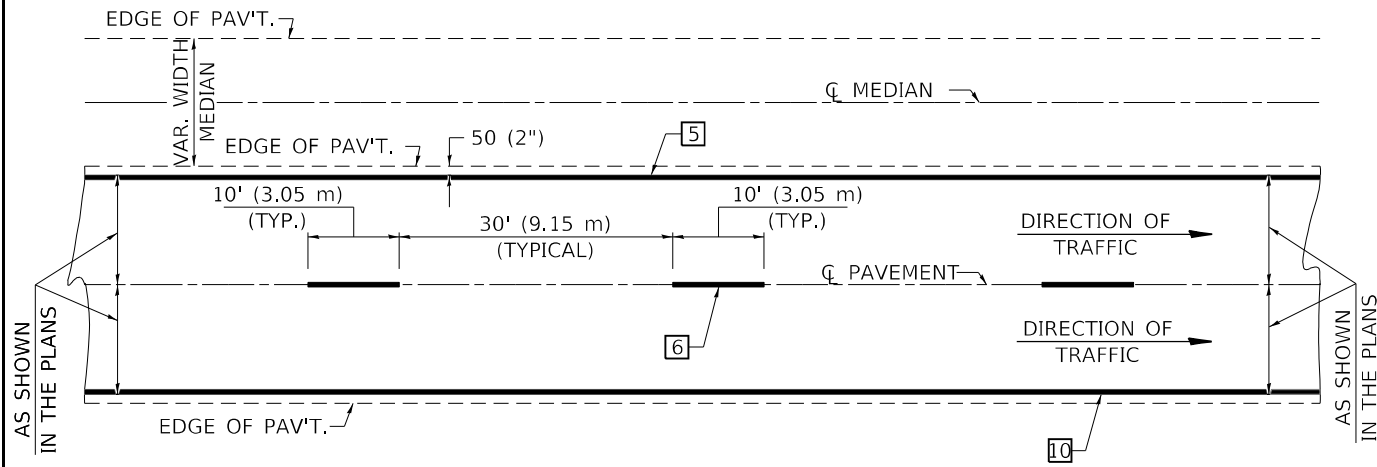

NOTE: PAVEMENT MARKINGS ARE TO BE EXTENDED THROUGH OMISSIONS WHEN APPLICABLE.

NOTE: SEE ARTICLES 780.04 & 781.03 FOR LOCATION OF STRIPES AND MARKERS RELATIVE TO EDGES OR JOINTS.

FOR RAISED REFLECTIVE PAVEMENT MARKERS, REFER TO STANDARD 781001.

**TYPICAL PAVEMENT MARKING LEGEND**

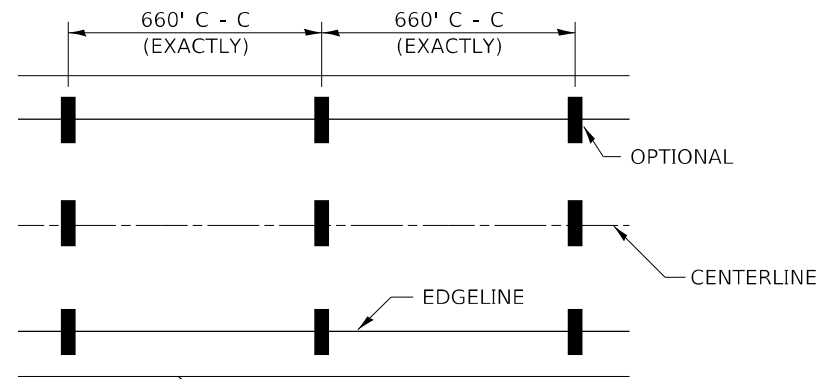

- 1 4" (100) SKIP-DASH (YELLOW)
- 2 4" (100) SOLID (YELLOW)
- 3 12" (300) DIAGONAL (YELLOW)
- 4 4" (100) DOUBLE YELLOW (NARROW)
- 5 6" (150) SOLID (YELLOW)
- 6 6" (150) SKIP-DASH (WHITE)
- 7 4" (100) SKIP-DASH (WHITE)
- 8 4" (100) SOLID (WHITE)
- 9 12" (300) DIAGONAL (WHITE)
- 10 6" (150) SOLID (WHITE)
- 11 24" (600) STOP BAR (WHITE)
- 12 8" (200) SOLID (WHITE)
- 13 6" (150) LANE LINE EXTENSIONS (WHITE)

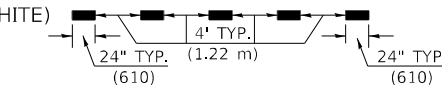
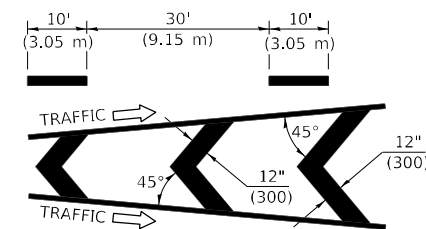
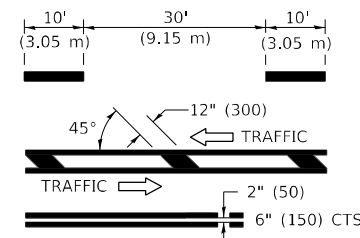

**TYPICAL EXIT RAMP TERMINAL**

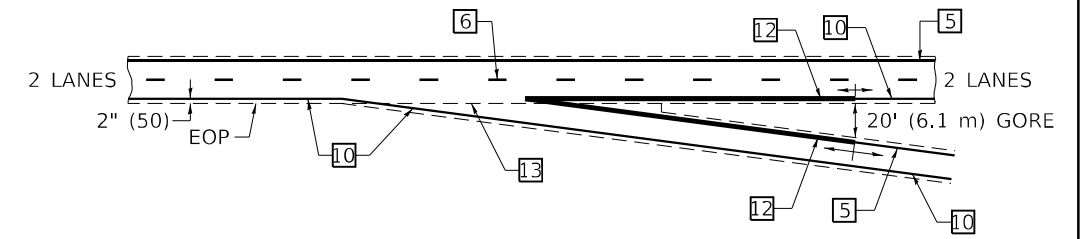

**EXIT RAMP TERMINAL with EXCLUSIVE (auxiliary) LANE**

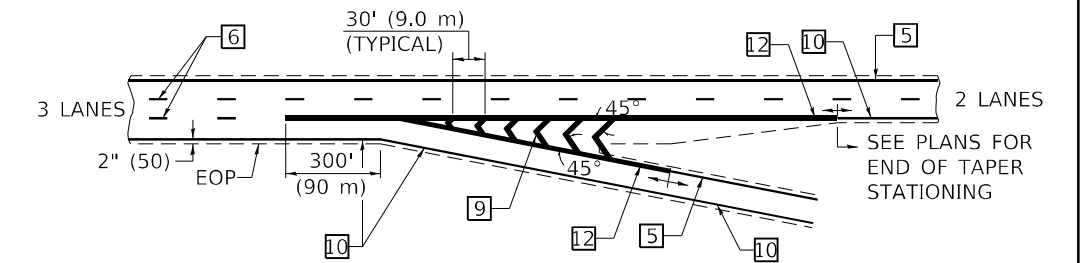

**TYPICAL ENTRANCE RAMP TERMINAL**

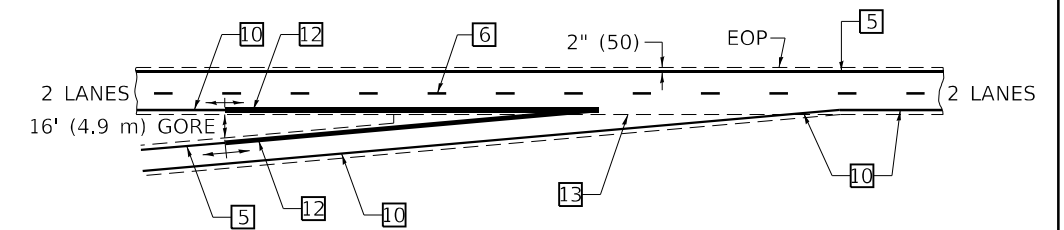

**ENTRANCE RAMP TERMINAL with EXCLUSIVE LANE**

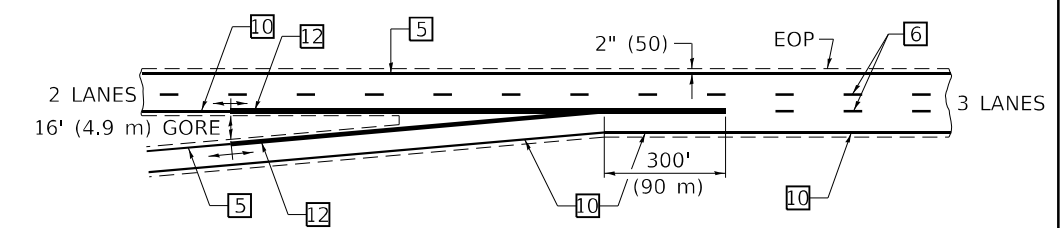

IT WILL BE NECESSARY TO HAVE A REPRESENTATIVE OF THE STATE POLICE PRESENT SO THAT THE ACCURACY OF MEASUREMENT CAN BE ATTESTED TO IN COURT.

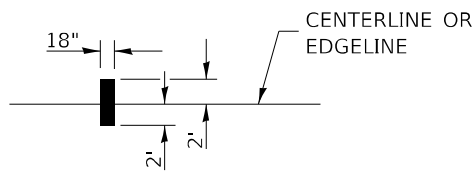

**AERIAL SPEED CHECK ZONES**

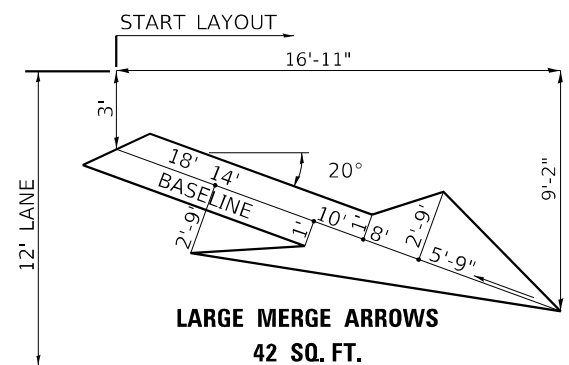

Note: All dimensions are in INCHES (millimeters) unless otherwise shown.

MODEL: D:\cadd\... FILE NAME: P:\Effingham\70D64... ORDER: #6\cadd\Sheet\70D64... DATE: 10/21/2021



USER NAME = rhanland	DESIGNED - WMK	REVISED -
DRAWN - DMM	REVISIONS -	
PLOT SCALE = 40,0000' / in.	CHECKED - RLH	REVISED -
PLOT DATE = 10/21/2021	DATE - 10/21/2021	REVISED -

**STATE OF ILLINOIS DEPARTMENT OF TRANSPORTATION**

**PAVEMENT MARKING (INTERSTATE & MULTI-LANE APPLICATIONS)**

SCALE: N.T.S. SHEET 1 OF 1 SHEETS STA. TO STA.

DISTRICT 5 DETAIL NO. 7800BBBB				
F.A.I. RTE.	SECTION	COUNTY	TOTAL SHEETS	SHEET NO.
55	(57-1,57-2)BDS	MCLEAN	88	85
CONTRACT NO. 70D64				
ILLINOIS FED. AID PROJECT				

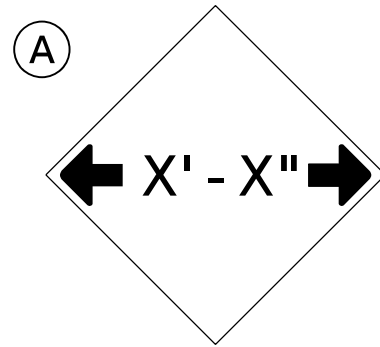

**W12-2(O)-48"x48"(1200x1200)**

SIGN (A) 2 SIGNS - W12-2(O)-48"x48"(1200x1200) ARE TO BE PLACED AS SHOWN IN THE PLANS OR AS DIRECTED BY THE ENGINEER.

SIGN (B) 2 SIGNS - (SIGN PANEL, TYPE II) AS SHOWN ARE TO BE PLACED AS SHOWN IN THE PLANS OR AS DIRECTED BY THE ENGINEER.

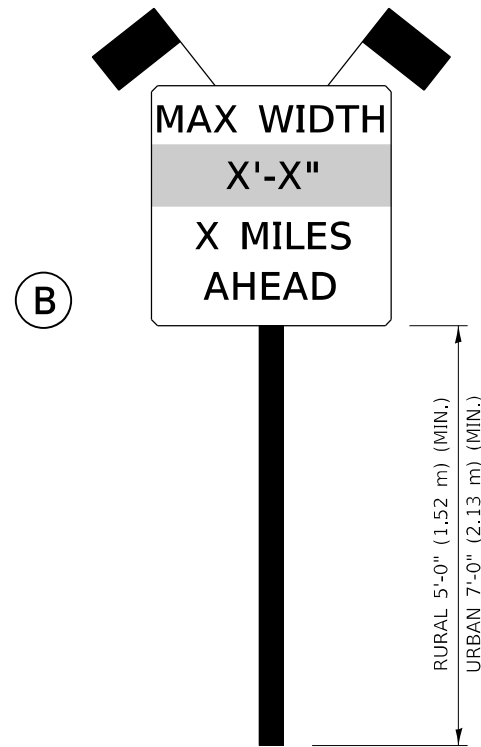

**SIGN PANEL, TYPE II**

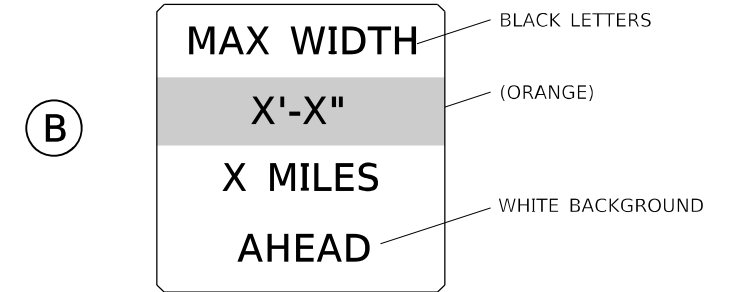

(B)

**W12-I103(O)-48"x48"(1200x1200)  
"D" LETTERS/NUMBERS**

NORTHBOUND STAGE WIDTHS:

- 057-0183
- STAGE 1 WIDTH = 17'-3" ACTUAL: 15'-9": REQUIRED
- STAGE 2 WIDTH = 13'-3" ACTUAL: 11'-9": REQUIRED
- 057-0174
- STAGE 1 WIDTH = 17'-0" ACTUAL: 15'-6": REQUIRED
- STAGE 2 WIDTH = 13'-6" ACTUAL: 12'-0": REQUIRED
- 057-0153
- STAGE 1 WIDTH = 29'-3" ACTUAL: POSTING NOT REQUIRED
- STAGE 2 WIDTH = 13'-3" ACTUAL: 11'-9": REQUIRED
- 057-0179
- STAGE 1 WIDTH = 13'-3" ACTUAL: 11'-9": REQUIRED
- STAGE 2 WIDTH = 13'-3" ACTUAL: 11'-9": REQUIRED

SOUTHBOUND STAGE WIDTHS:

- 057-0182
- STAGE 1 WIDTH = 17'-3" ACTUAL: 15'-9": REQUIRED
- STAGE 2 WIDTH = 13'-3" ACTUAL: 11'-9": REQUIRED
- 057-0173
- STAGE 1 WIDTH = 17'-0" ACTUAL: 15'-6": REQUIRED
- STAGE 2 WIDTH = 13'-6" ACTUAL: 12'-0": REQUIRED
- 057-0152
- STAGE 1 WIDTH = 17'-3" ACTUAL: 15'-9": REQUIRED
- STAGE 2 WIDTH = 13'-3" ACTUAL: 11'-9": REQUIRED
- 057-0178
- STAGE 1 WIDTH = 13'-3" ACTUAL: 11'-9": REQUIRED
- STAGE 2 WIDTH = 13'-3" ACTUAL: 11'-9": REQUIRED

**GENERAL NOTES**

1. ALL TRAFFIC CONTROL DEVICES SHALL BE FURNISHED, ERECTED AND MAINTAINED BY THE CONTRACTOR.
2. ALL (B) SIGNS SHALL HAVE FLAGS INSTALLED UNLESS OTHERWISE DIRECTED.
3. LOCATIONS OF TRAFFIC CONTROL DEVICES MAY BE ADJUSTED BY THE ENGINEER.
4. ALL TRAFFIC CONTROL SHOWN ON THIS SHEET SHALL BE PAID FOR AT THE CONTRACT LUMP SUM PRICE FOR WIDTH RESTRICTION SIGNING.
5. ALL SIGNS SHALL BE POST MOUNTED UNLESS OTHERWISE DIRECTED.
6. ALL SIGNS SHOWN ORANGE (O) SHALL BE FLUORESCENT ORANGE.
7. ALL SIGNS SHOWN SHALL CONSIST OF THE CURRENT RETROREFLECTIVE SHEETING REQUIREMENTS AS OUTLINED IN SECTION 1106.01 OF THE STANDARD SPECIFICATIONS BOOK.

NOTES:  
MAX WIDTH - SEE MAINTENANCE OF TRAFFIC PLANS FOR SIGN LOCATIONS

MODEL: D:\cadd\11\11001\11001.DWG; PLOT: 11001.DWG; USER: rhanfland; DATE: 10/21/2021; FILE: 11001.DWG; PLOT: 11001.DWG; ORDER: #60; CADD: 11001.DWG; DATE: 10/21/2021; WIDTH: 11001.DWG; SIGN: 11001.DWG



**CIVIL DESIGN, INC.**  
WBE / DBE  
EFFINGHAM, IL  
LICENSE # 184.003222

USER NAME = rhanfland	DESIGNED - WMK	REVISED -
DRAWN - DMM	REVISED -	
PLOT SCALE = 40,0000 ' / in.	CHECKED - RLH	REVISED -
PLOT DATE = 10/21/2021	DATE - 10/21/2021	REVISED -

**STATE OF ILLINOIS  
DEPARTMENT OF TRANSPORTATION**

**WIDTH RESTRICTION SIGNING**

SCALE: N.T.S. SHEET 1 OF 1 SHEETS STA. TO STA.

**DISTRICT 5 DETAIL NO. X7200201**

F.A.I. RTE.	SECTION	COUNTY	TOTAL SHEETS	SHEET NO.
55	(57-1,57-2)BD5	MCLEAN	88	86
				CONTRACT NO. 70D64
ILLINOIS FED. AID PROJECT				

DATE	
BY	
SURVEYED	
PLOTTED	
TEMPLATE	
AREAS	
CHECKED	
FINAL SURVEY	
NOTE BOOK	
NO.	

DATE	
BY	
SURVEYED	
PLOTTED	
TEMPLATE	
AREAS	
CHECKED	
ORIGINAL SURVEY	
NOTE BOOK	
NO.	

MODEL: Default  
 FILE NAME: P:\effingham\13454 - PTB 108 100T DS 1\work Order #40\Draw Sheet\0570012.stb\_xsec.dgn

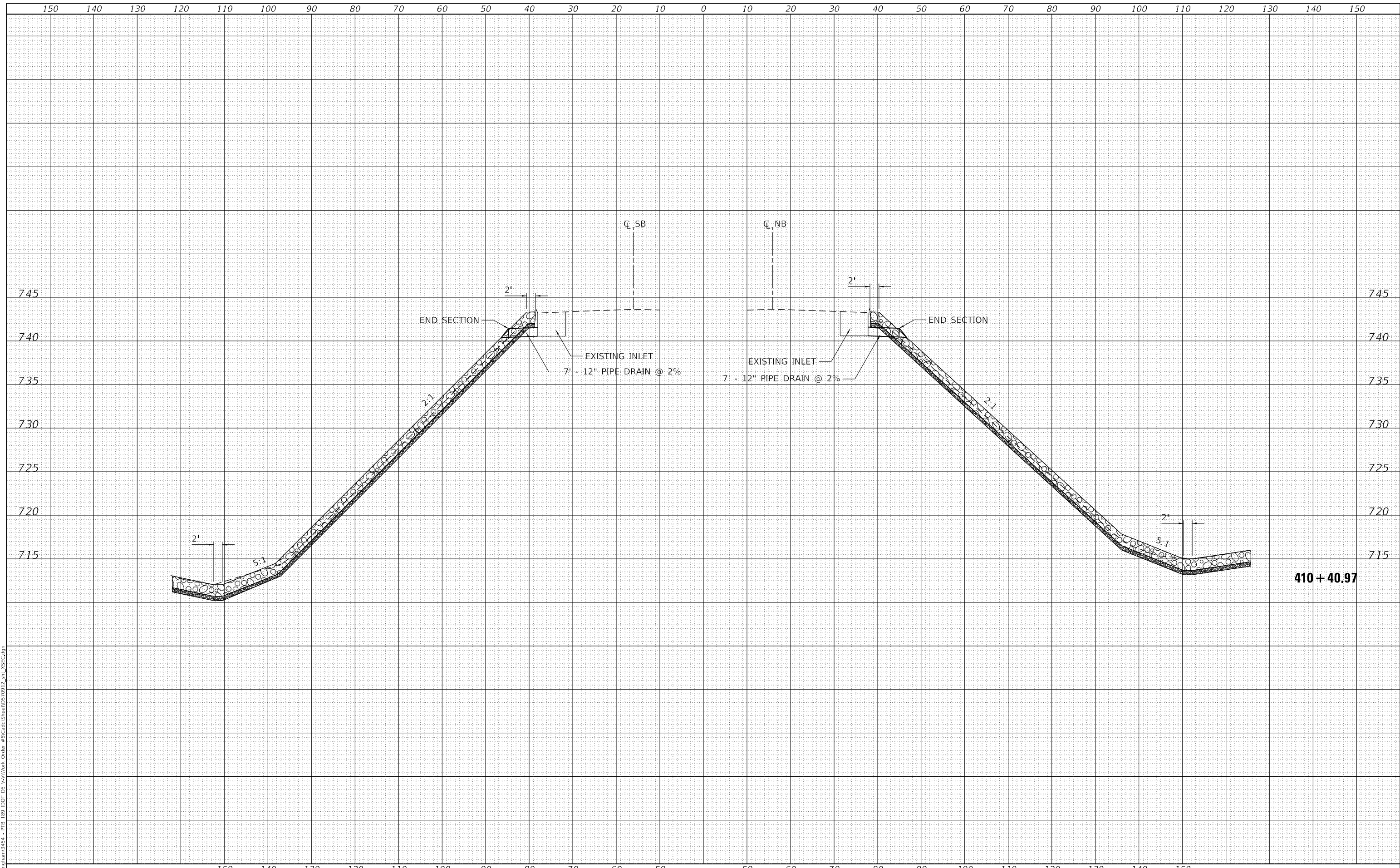

**CIVIL DESIGN, INC.**  
 WBE / DBE  
 EFFINGHAM, IL  
 LICENSE # 184.003222

USER NAME = rhanfland	DESIGNED -	REVISED -
	DRAWN -	REVISED -
PLOT SCALE = 20,0000 * / in.	CHECKED -	REVISED -
PLOT DATE = 10/21/2021	DATE -	REVISED -

**STATE OF ILLINOIS  
 DEPARTMENT OF TRANSPORTATION**

SCALE:		SHEET 1	OF 2	SHEETS	STA. 410+22.27	TO STA. 410+40.97
--------	--	---------	------	--------	----------------	-------------------

F.A.J. RTE.	SECTION	COUNTY	TOTAL SHEETS	SHEET NO.
55	(55-1,57-2)BD5	MCLEAN	88	87
CONTRACT NO. 70D64				
ILLINOIS FED. AID PROJECT				



DATE	
BY	
FINAL SURVEY	SURVEYED
NOTE BOOK	PLOTTED
NO.	TEMPLATE
	AREAS CHECKED

DATE	
BY	
ORIGINAL SURVEY	SURVEYED
NOTE BOOK	PLOTTED
NO.	TEMPLATE
	AREAS CHECKED

MODEL: Default  
 FILE NAME: P:\effingham\184-54 - P7B 108 100T D5 1\Work Order 45\Cadd\Sheet\0570D12.stb\_ASEC.dgn

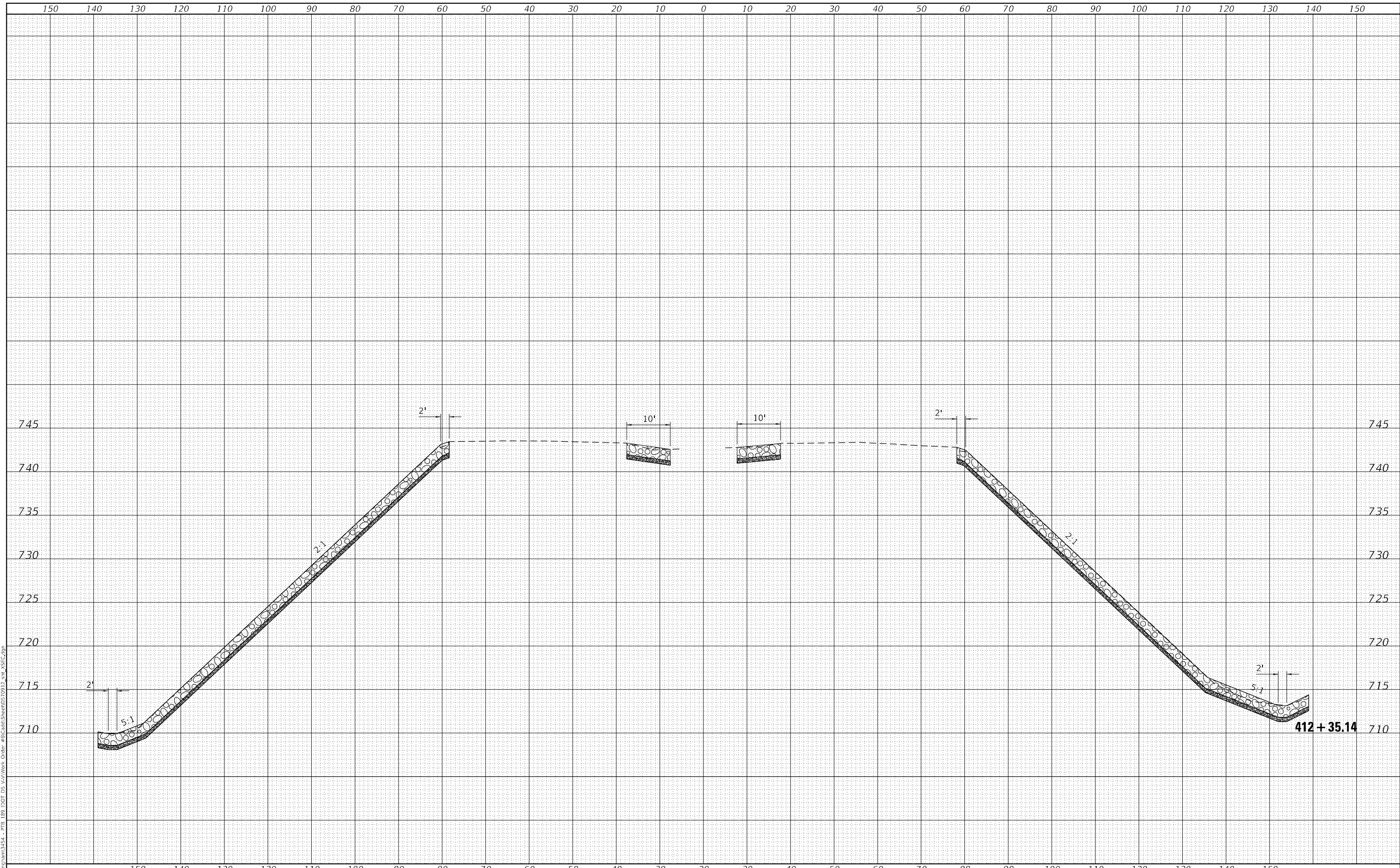

USER NAME = rhanfland	DESIGNED -	REVISED -
	DRAWN -	REVISED -
PLOT SCALE = 20,0000 * / in.	CHECKED -	REVISED -
PLOT DATE = 10/21/2021	DATE -	REVISED -

**STATE OF ILLINOIS  
 DEPARTMENT OF TRANSPORTATION**

<b>CROSS SECTIONS</b>	
SCALE:	SHEET 2 OF 2 SHEETS STA. 412+35.14 TO STA. 412+35.14

F.A.J. RTE.	SECTION	COUNTY	TOTAL SHEETS	SHEET NO.
55	(57-1,57-2)BDS	MCLEAN	88	88
CONTRACT NO. 70D64			ILLINOIS FED. AID PROJECT	