

PLAN

**GENERAL NOTES**

A Concrete Sealer shall be applied to the surfaces of the deck and parapets (See Special Provisions for BRIDGE DECK CONCRETE SEALER).  
 Existing pavement markings shall be temporarily covered prior to application of the deck surface treatment, to prevent the material from being applied over the markings. The temporary covering shall be removed after the application of the deck surface treatment and prior to opening to traffic. Cost included with Concrete Sealer.

**TOTAL BILL OF MATERIAL**

ITEM	UNIT	SUPER	SUB	TOTAL
Concrete Sealer	Sq. Ft.	17,305		17,305

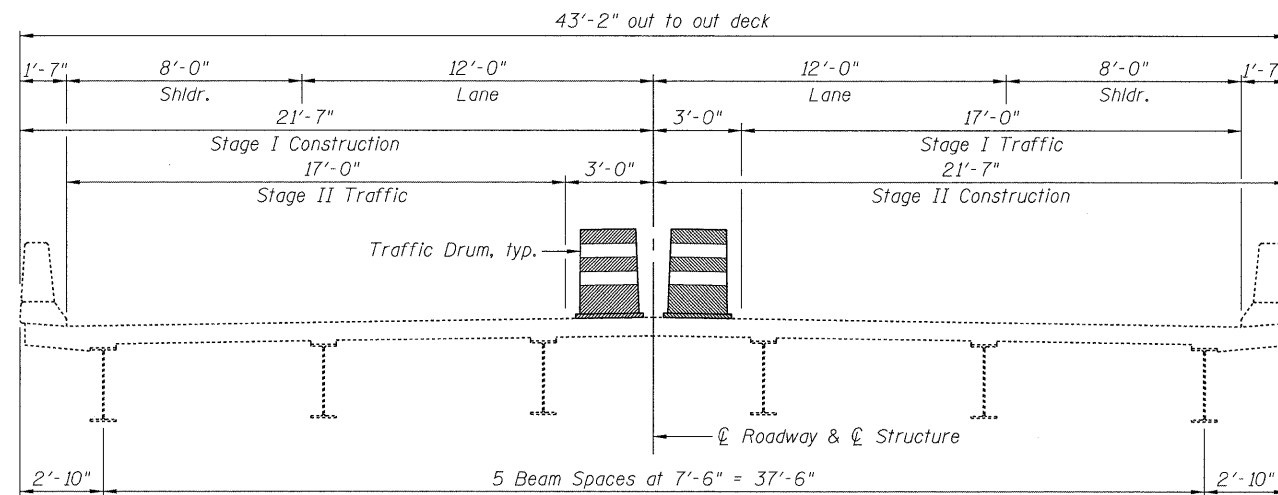

**CROSS SECTION**  
(Looking South)

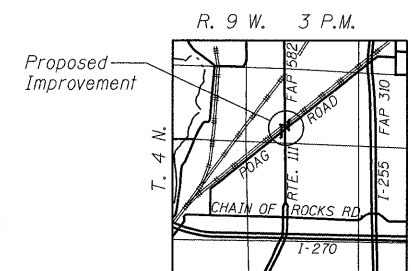

LOCATION SKETCH

**GENERAL PLAN**  
**IL. RTE 111 OVER POAG ROAD & N&W RR**  
**F.A.P. RTE 582**  
**SEC. DIST. 8 BRIDGE DECK 2011-4**  
**MADISON COUNTY**  
**STATION 781+99.76**  
**STRUCTURE NO. 060-0123**

**CB** Coombe-Bloxdorf P.C.  
 - CIVIL ENGINEERS -  
 - STRUCTURAL ENGINEERS -  
 - LAND SURVEYORS -  
 Design Firm License No. 184-002703

PROJECT NO. 09025-4  
 SCALE  
 DATE 8/16/10  
 DESIGN BY MCB  
 DRAWN BY MML  
 CHECKED BY

SHEET NO. 9  
 23 SHEETS

F.A. RTE.	SECTION	COUNTY	TOTAL SHEETS	SHEET NO.
VAR.	DIST 8 BRIDGE DECK 2011-4	MADISON	29	15
CONTRACT NO. 76E44				
FED. ROAD DIST. NO.	ILLINOIS FED. AID PROJECT			