

ELEVATION AT PIER

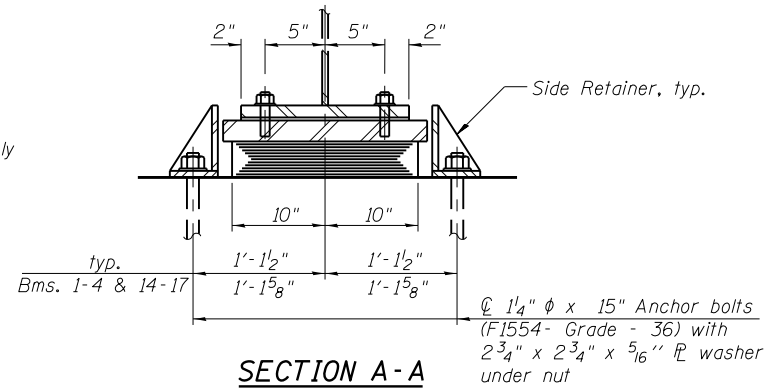

SECTION A-A

TYPE I ELASTOMERIC EXP. BRG.

(Pier 2)

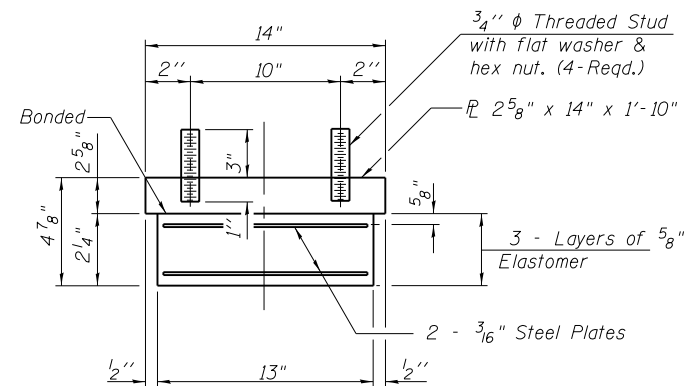

BEARING ASSEMBLY

Note:
Shim plates shall not be placed under Bearing Assembly.

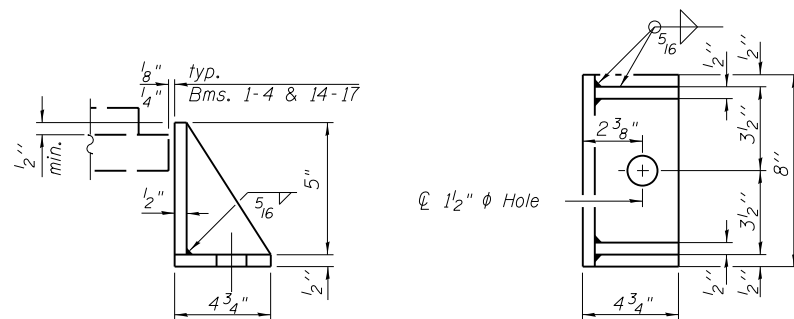

SIDE RETAINER

Equivalent rolled angle with stiffeners will be allowed in lieu of welded plates.

Notes:
Anchor bolts shall be ASTM F1554 all-thread (or an Engineer-approved alternate material) of the grade(s) and diameter(s) specified. The corresponding specified grade of AASHTO M314 anchor bolts may be used in lieu of ASTM F1554.
Anchor bolts at fixed bearings may be either cast in place or installed in holes drilled after the supported member is in place.
Anchor bolts for side retainers may be cast in place or installed in holes drilled before or after members are in place.
Drilled and set anchor bolts shall be installed according to Article 521.06 of the Standard Specifications.
Side retainers and other steel members required for the elastomeric bearing assembly shall be included in the cost of Elastomeric Bearing Assembly, Type I.
The structural steel plates of the Bearing Assembly shall conform to the requirements of AASHTO M 270 Grade 50.
Two 1/8 in. adjusting shims shall be provided for each bearing in addition to all other plates or shims and placed as shown on bearing details.
The structural steel plates and pintles of the Fixed Bearing shall conform to the requirements of AASHTO M 270 Grade 50.

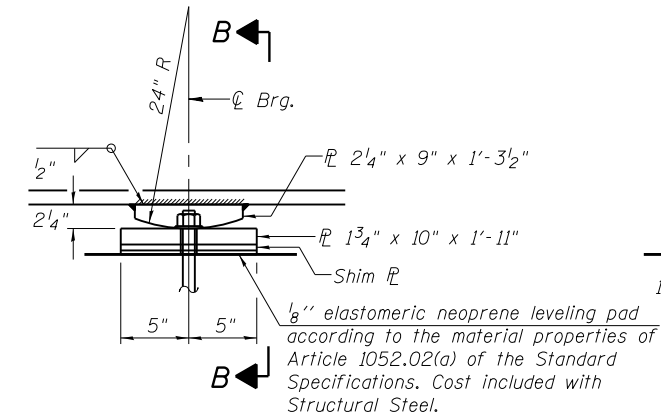

ELEVATION AT PIER

FIXED BEARING

(Pier 1)

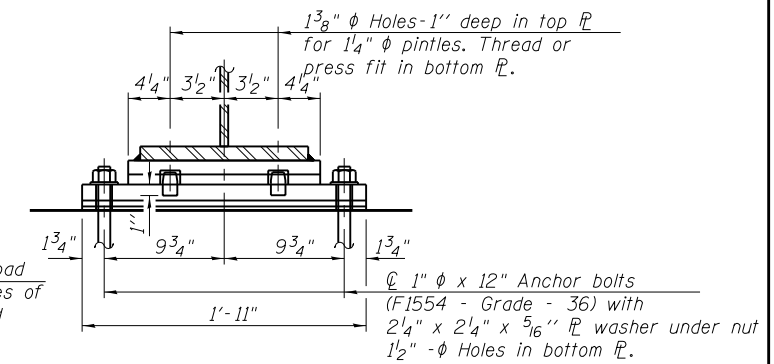

SECTION B-B

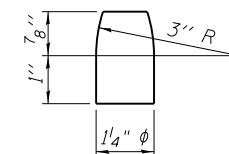

PINTLE

BILL OF MATERIAL

Item	Unit	Total
Elastomeric Bearing Assembly Type I	Each	17
Anchor Bolts, 1"	Each	34
Anchor Bolts, 1 1/4"	Each	34

I-2E-1

1-27-12

Bollinger, Lach & Associates, Inc.
ITASCA, ILLINOIS

USER NAME =	DESIGNED - JJI	REVISED
PLOT SCALE =	CHECKED - JMT	REVISED
PLOT DATE = \$DATE\$	DRAWN - GM	REVISED
	CHECKED - JMT	REVISED

STATE OF ILLINOIS
DEPARTMENT OF TRANSPORTATION

PIER BEARINGS
STRUCTURE NO. 016-3035

SHEET NO. 36 OF 62 SHEETS

F.A.P. RTE. 307	SECTION 541Y-3-B	COUNTY COOK	TOTAL SHEETS 143	SHEET NO. 97
CONTRACT NO. 60J11				
ILLINOIS FED. AID PROJECT				