

**CONCRETE REMOVAL**

- CONCRETE REMOVAL
- CLSM AREA (SEE PLAN VIEW)

**DETAIL NOTES:**

BOX CULVERTS SHALL BE CLEANED BY THE CONTRACTOR PRIOR TO FILLING. THE CONTRACTOR SHALL ESTABLISH A SUITABLE PLAN FOR CLEANING THE EXISTING BOX CULVERTS TO THE SATISFACTION OF THE ENGINEER.

REMOVAL OF EXISTING HEADWALLS AND PORTIONS OF THE EXISTING BOX CULVERT SHALL BE REMOVED PRIOR TO FILLING.

ALL MEASUREMENTS AND DIMENSIONS ARE BASED ON AS-BUILT PLAN INFORMATION. ALL DIMENSIONS AND MEASUREMENTS SHALL BE VERIFIED BY THE ENGINEER PRIOR TO REMOVAL. THE ENGINEER MAY MODIFY THE REMOVAL AREAS.

EXPANSION BOLTS SHALL CONSIST OF SELF DRILLING EXPANSION SHIELDS & 3/4" DIA. HOOKED BOLTS. BOLTS SHALL EXTEND A MINIMUM OF 9" INTO EXISTING CONCRETE.

ALL COSTS ASSOCIATED WITH CLEANING THE EXISTING BOX CULVERTS, CONCRETE REMOVAL, EXPANSION BOLTS, WELDED WIRE FABRIC, CONCRETE BOX CULVERTS, CONTROLLED LOW STRENGTH MATERIAL WILL NOT BE MEASURED FOR PAYMENT BUT SHALL BE INCLUDED IN THE CONTRACT UNIT PRICE OF CU YDS FOR CONTROLLED LOW STRENGTH MATERIAL. NO ADDITIONAL COMPENSATION WILL BE ALLOWED.

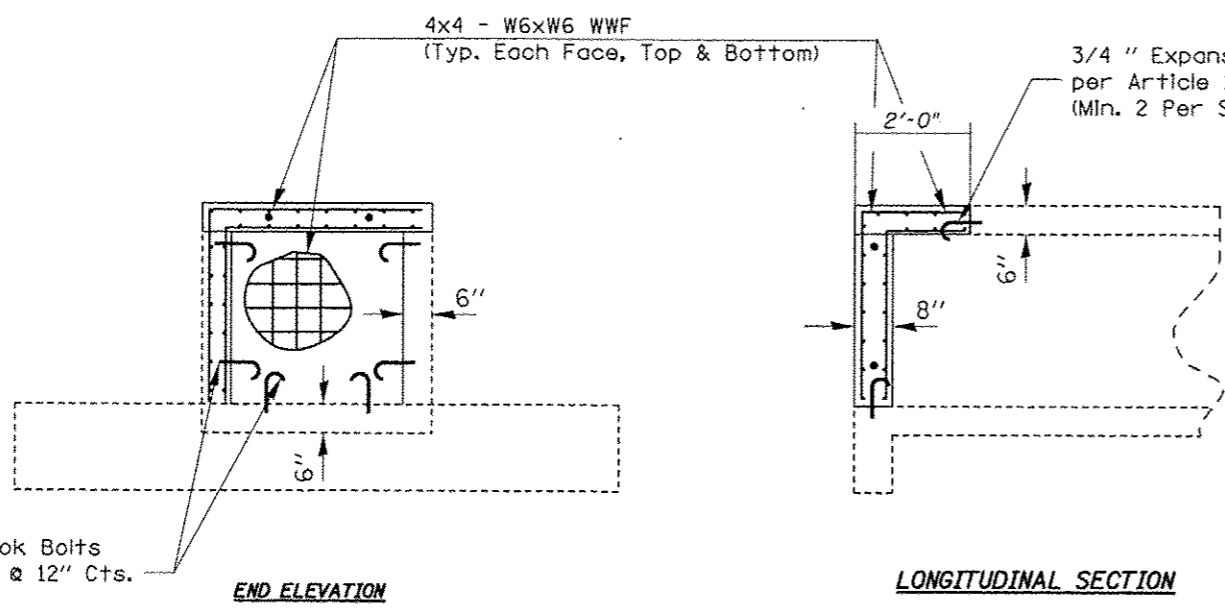

**CONCRETE BOX CULVERTS**

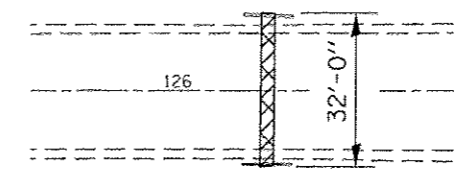

**PLAN VIEW**

**(FOR INFORMATION ONLY)  
TOTAL BILL OF MATERIAL**

Item	Unit	Total
BOX CULVERTS TO BE CLEANED	FOOT	32.0
CONCRETE REMOVAL	CU YD	2.2
3/4" EXP. BOLTS	EACH	16.0
WELDED WIRE FABRIC	SQ FT	28.0
CONCRETE BOX CULVERTS	Each	0.60

**METHOD OF PAYMENT**

Item	Unit	Total
CONTROLLED LOW STRENGTH MATERIAL	CU YD	8.0

DRAWING NOT TO SCALE