

ARROW TO INDICATE THE DIRECTION OF THE CABLE RUN

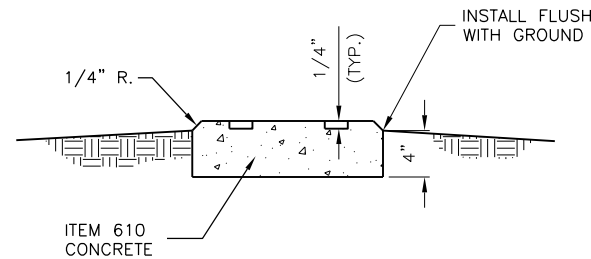

TURF CABLE / SPLICE MARKER
N.T.S.

NOTES

1. CABLE MARKERS SHALL BE INSTALLED AT ALL BENDS AND EVERY 200' ALONG THE HOMERUN.
2. ITEM 610 CONCRETE SHALL BE USED.
3. ALL EXPOSED EDGES SHALL BE EDGED WITH A 1/4" RADIUS TOOL.
4. THE COST OF FURNISHING AND INSTALLING NEW MARKERS SHALL BE INCIDENTAL TO THE ASSOCIATED ITEMS.
5. 0.049 CU. YD. CONCRETE PER MARKER.
6. A MARKER CONFORMING TO THIS DETAIL MARKED "SPLICE" SHALL BE INSTALLED AT ALL SPLICE LOCATIONS NOT IN LIGHT CANS OR MANHOLES.

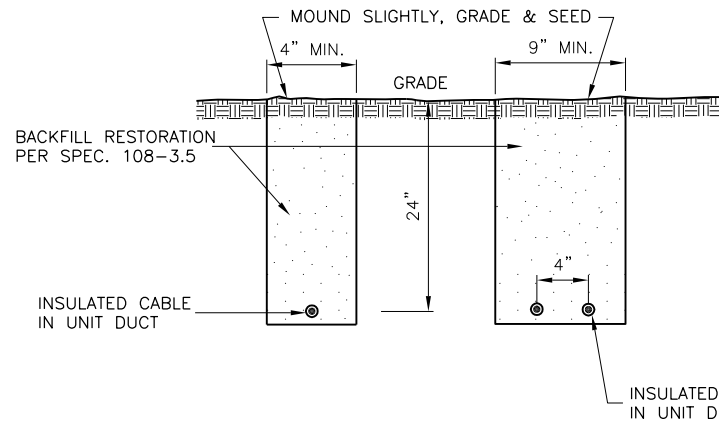

TRENCH DETAIL
N.T.S.

NOTES

1. TRENCHES WITH MORE THAN 2 CABLES SHALL BE INCREASED 3" IN WIDTH FOR EACH ADDITIONAL CABLE. IF SPECIFIED ON PLANS, TWO PARALLEL TRENCHES MAY BE CONSTRUCTED.
2. DEPTH OF TRENCHES SHALL BE AS SHOWN ABOVE UNLESS OTHERWISE SPECIFIED ON THE PLANS.
3. SAND BACKFILL SHALL BE USED IF THE EXISTING SOIL DOES NOT MEET THE BACKFILL REQUIREMENTS.
4. ALL DISTURBED SURFACES SHALL BE RESTORED TO THEIR ORIGINAL CONDITION. COST IS INCIDENTAL TO ITEM 108.

NOTE: AT CONTRACTOR'S OPTION, CABLE PLOWING MAY BE USED IN LIEU OF TRENCHING

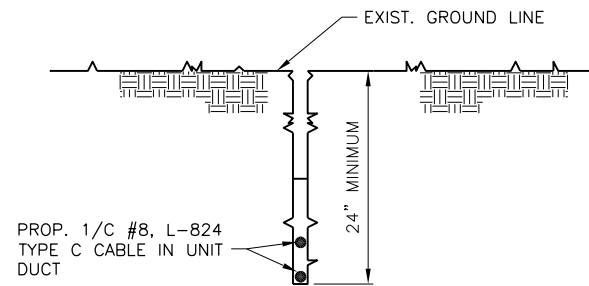

PROP. 1/C #8, L-824
TYPE C CABLE IN UNIT
DUCT

NOTE: WHERE TWO UNIT DUCTS ARE TO BE INSTALLED, CONTRACTOR MAY PLOW UNIT DUCTS SEPERATELY (SIDE BY SIDE)

CABLE IN UNIT-DUCT - PLOWED
N.T.S.

VE049

REVISIONS		
NUMBER	BY	DATE

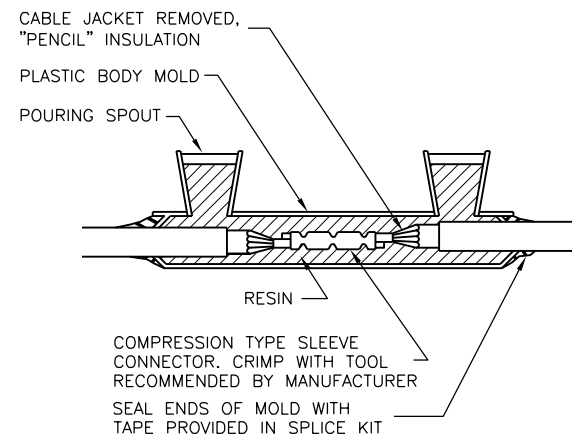
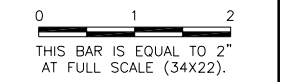

FOR IN-LINE CONNECTIONS OF EXISTING CABLES CUT DURING CONSTRUCTIONS.

TYPE A

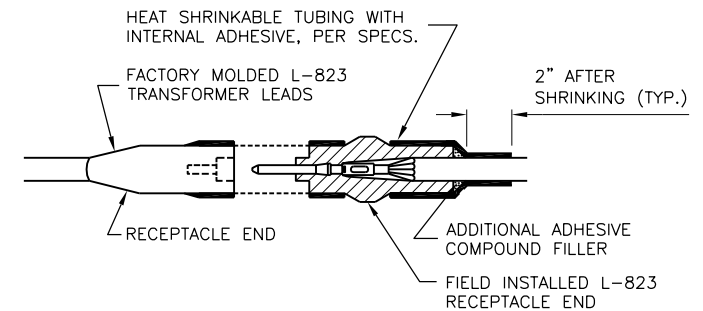

FOR SPLICES AT TAXIWAY LIGHTS AND SIGNS.

TYPE C

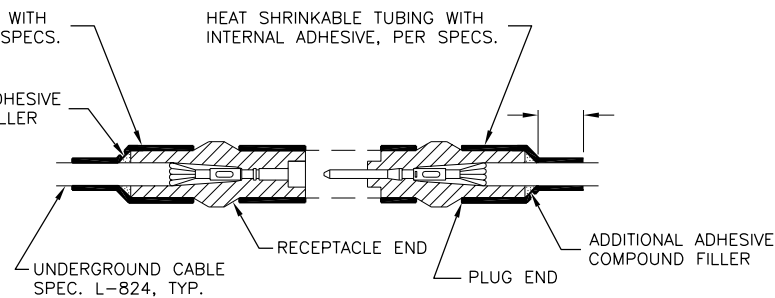

NOT TO BE USED IN THIS PROJECT UNLESS OTHERWISE DIRECTED BY ENGINEER

TYPE B

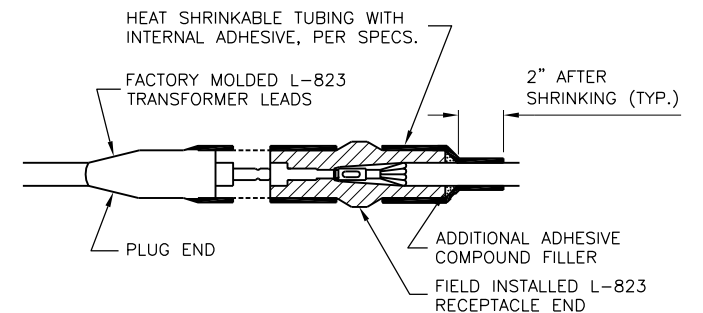

FOR SPLICES AT TAXIWAY LIGHTS AND SIGNS.

TYPE D

CABLE SPLICES

N.T.S.

NOTES

1. INSIDE DIAMETER OF CONNECTOR SHALL PROPERLY MATCH THE OUTSIDE DIAMETER OF CABLE.
2. THE COST OF FURNISHING AND INSTALLING ALL SPLICE MATERIALS SHALL BE INCIDENTAL TO THE ASSOCIATED CABLE ITEMS.
3. THE CONTRACTOR SHALL HAVE A MINIMUM OF TWO (2) TYPE A SPLICE KITS ON THE JOB SITE AT ALL TIMES FOR EMERGENCY REPAIRS.

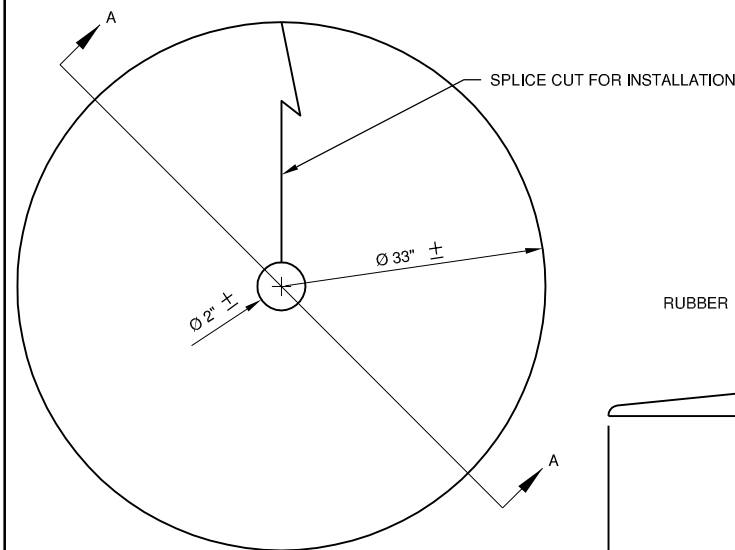

PLAN VIEW
N.T.S.

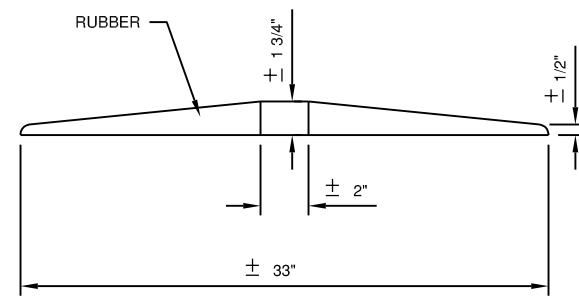

SECTION A-A
N.T.S.

VEGETATION CONTROL RING DETAIL
N.T.S.

VERMILION REGIONAL AIRPORT AUTHORITY
 VERMILION REGIONAL AIRPORT
 DANVILLE, ILLINOIS

REHABILITATE LIGHTS ON RUNWAY 16/34
 ELECTRICAL DETAILS 2

© Copyright CMT, Inc.
CMT
 CRAWFORD, MURPHY & TILL Y, INC.
 CONSULTING ENGINEERS
 License No. 184-000613



DESIGN BY:	TJH
DRAWN BY:	CMT
CHECKED BY:	AJB
APPROVED BY:	CET
DATE:	JANUARY 3, 2014
JOB No:	13042-01

IL. PROJ. NO. DNV-4234
 PROJ. NO. 3-17-SBGP-XX