

STATE OF ILLINOIS  
DEPARTMENT OF TRANSPORTATION

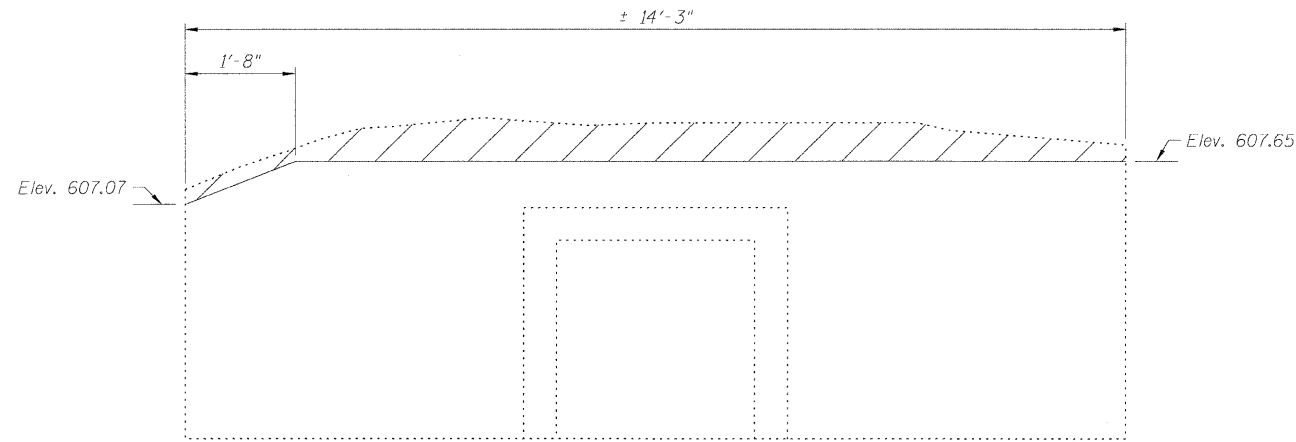

**EXISTING HEADWALL ELEVATION**

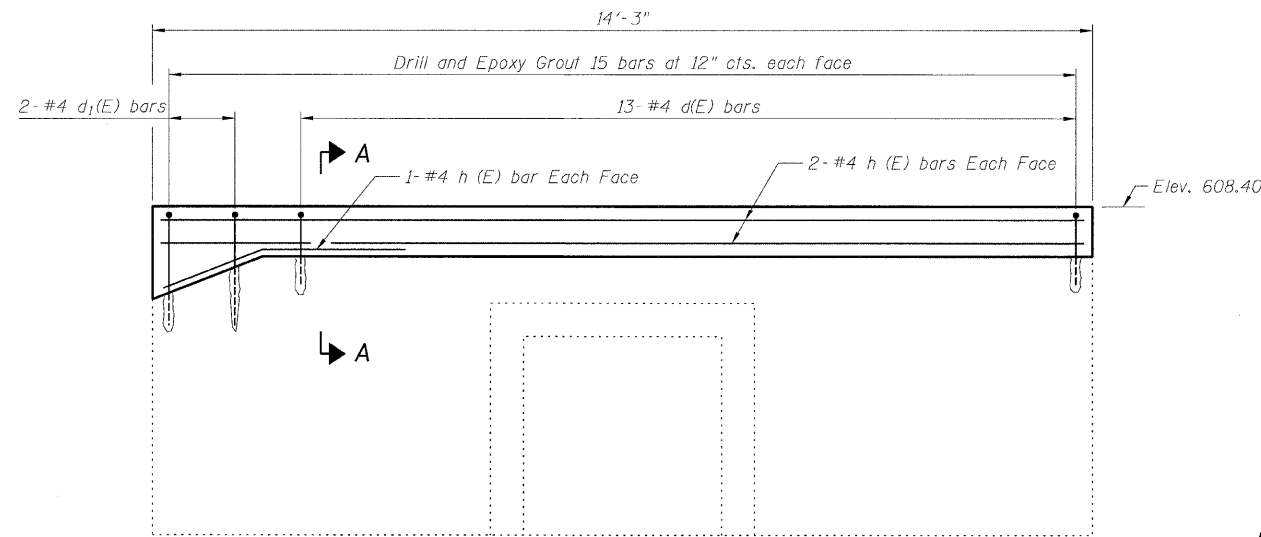

**PROPOSED HEADWALL ELEVATION**

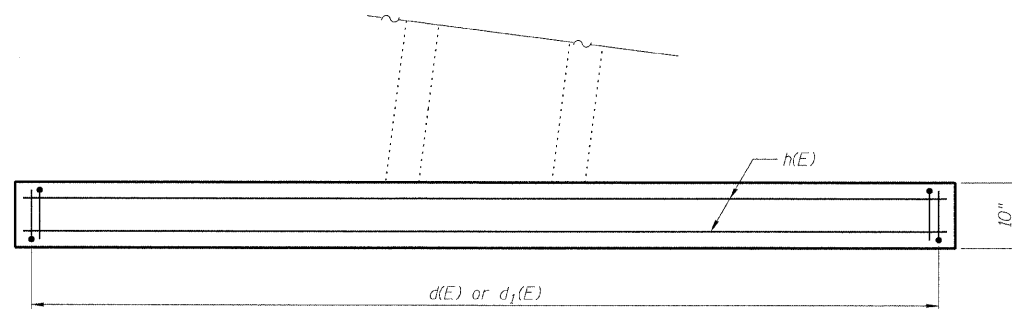

**PLAN**

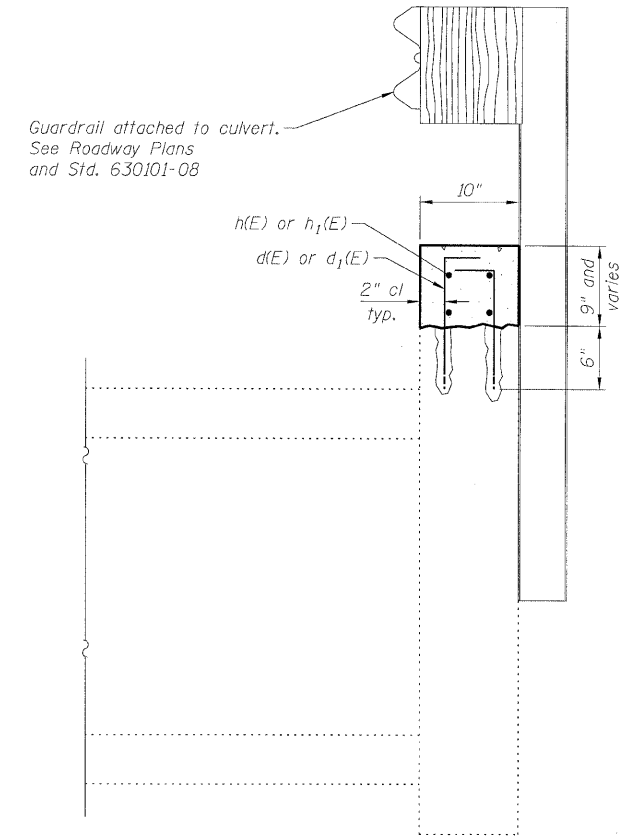

**SECTION A-A**

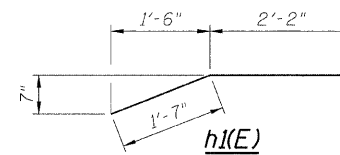
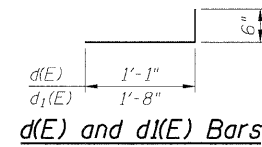

**TOTAL BILL OF MATERIAL**

Bar	No.	Size	Length	
d(E)	26	#4	1'-7"	
d1(E)	4	#4	2'-2"	
h(E)	4	#4	13'-11"	
h1(E)	2	#4	3'-9"	
Concrete Removal			Cu. Yd.	0.4
Structure Excavation			Cu. Yd.	1
Concrete Structure			Cu. Yd.	0.4
Reinforcement Bars, Epoxy Coated			Pound	80
Concrete Sealer			Sq. Ft.	25

**NOTES**

1. Reinforcement bars shall conform to the requirements of ASTM A 706 Gr 60. See Special Provision.
2. Reinforcement bars designated (E) shall be epoxy coated.
3. Drilling and epoxy grouting of reinforcement bars shall be included with the cost of Concrete Structure.
4. Existing vertical reinforcement shall be cleaned and incorporated into the new construction. Cost included with Concrete Removal.
5. Any reinforcement bars that are damaged during concrete removal operations shall be repaired or replaced using an approved bar splicer or anchorage system. Cost incidental to "Concrete Removal".
6. Concrete Sealer shall be applied to the exposed faces of the headwall.
7. Space the horizontal and vertical reinforcement bars to miss holes and/or anchors for the guardrail attachment.

**LEGEND:**



Concrete Removal

**HEADWALL REPAIR  
DETAILS  
STA. 366+65 RT**

DESIGNED -	AMK
CHECKED -	EKM
DRAWN -	RD
CHECKED -	EKM

SHEET NO. S-1	F.A. RTE.	SECTION	COUNTY	TOTAL SHEETS	SHEET NO.
	3565	2009-066 I	COOK	42	21
S-2 SHEETS	CONTRACT NO.				
FED. ROAD DIST. NO. ILLINOIS FED. AID PROJECT					

8NAMEs

12/16/2009

N:\PROJ\3368-25\Design\Structural\CAD\3368\_25\_S-1.dgn