

016-2448: I-290WB RAMP TO I-94 NB  
LOCATION: .1 M W. CANAL

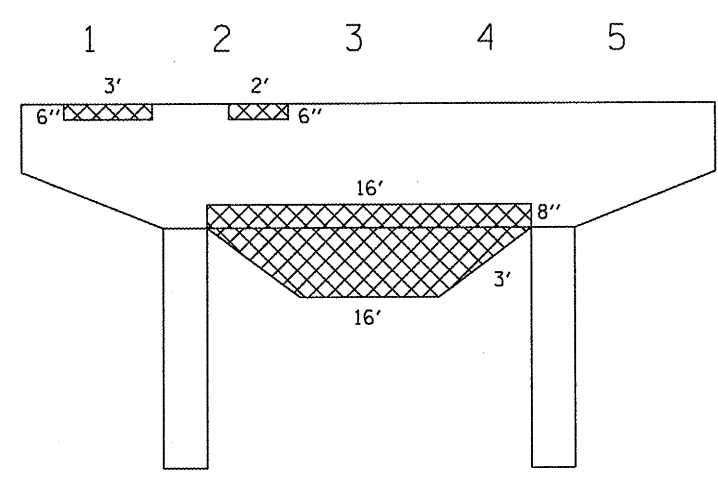

PIER E17 EAST FACE

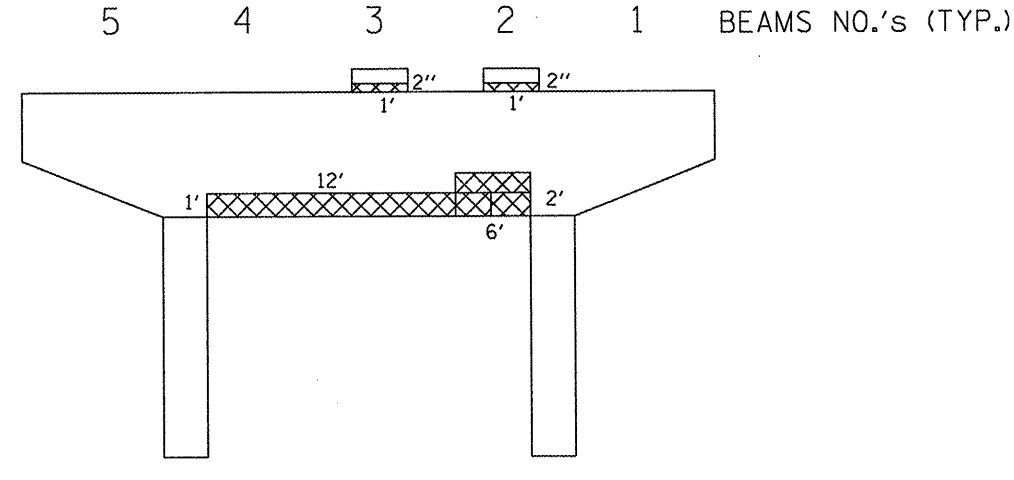

PIER E17 WEST FACE

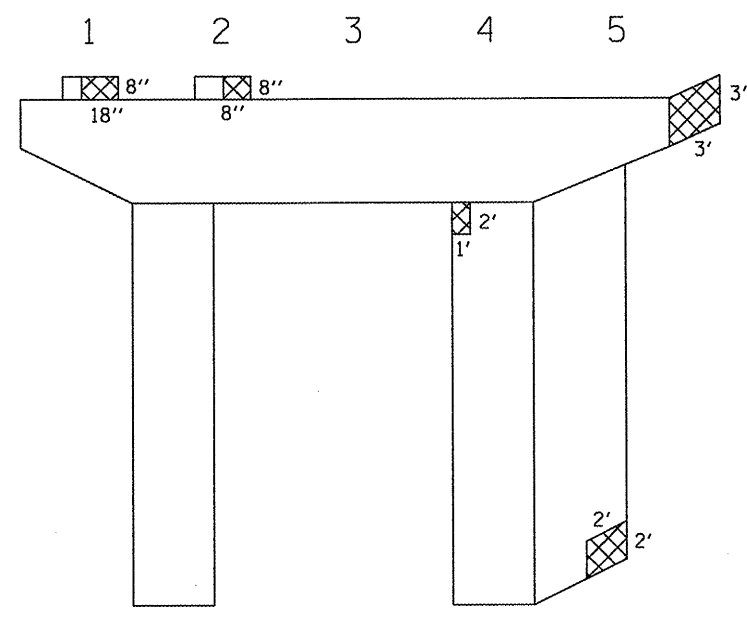

PIER 40 EAST FACE

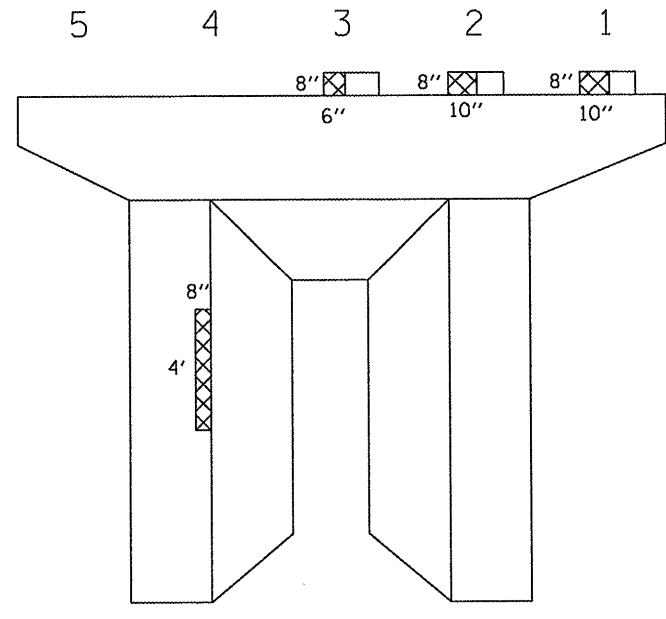

PIER 40 WEST FACE

SN 016-2448 TOTAL BILL OF MATERIAL

DESCRIPTION	UNIT	QUANTITY
STRUCTURAL REPAIR OF CONCRETE $\leq$ 5"	SQ FT	178

 STRUCTURAL REPAIR OF CONCRETE  $\leq$  5"

D:\181309-shr-plan.dgn 1/5/2010 11:11:45 AM User=estimablek