

OPTION 1

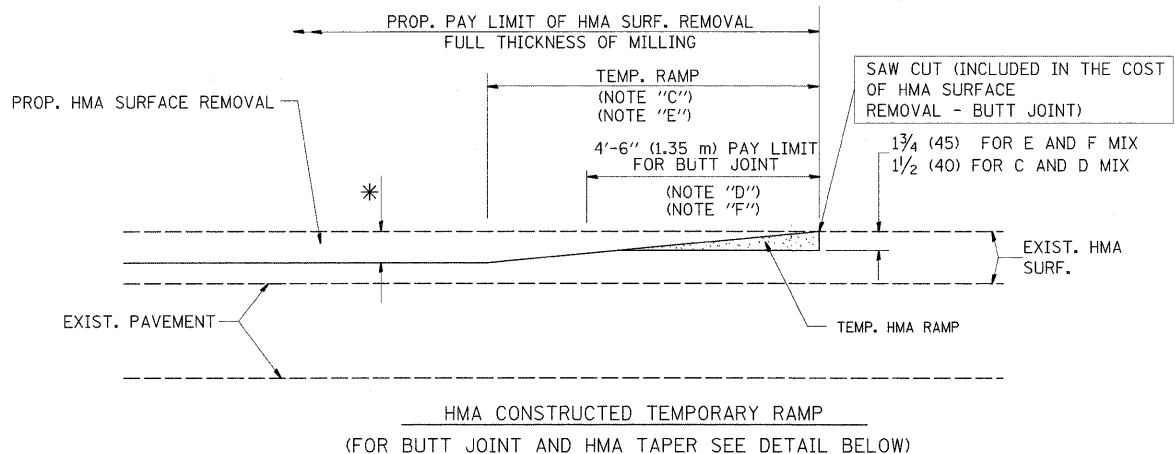

OPTION 2
TYPICAL TEMPORARY RAMP

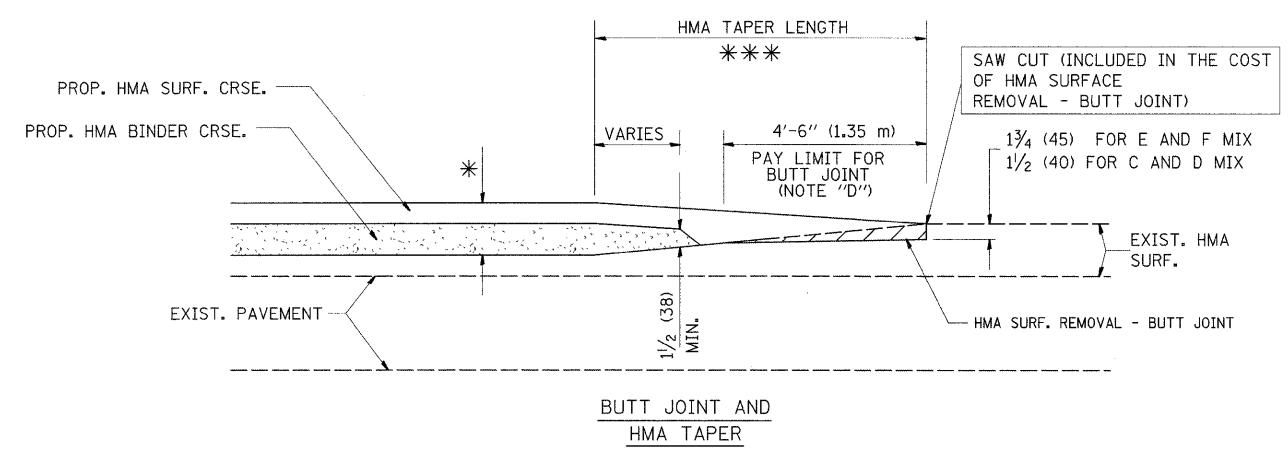

TYPICAL BUTT JOINT AND HMA TAPER FOR MILLING AND RESURFACING

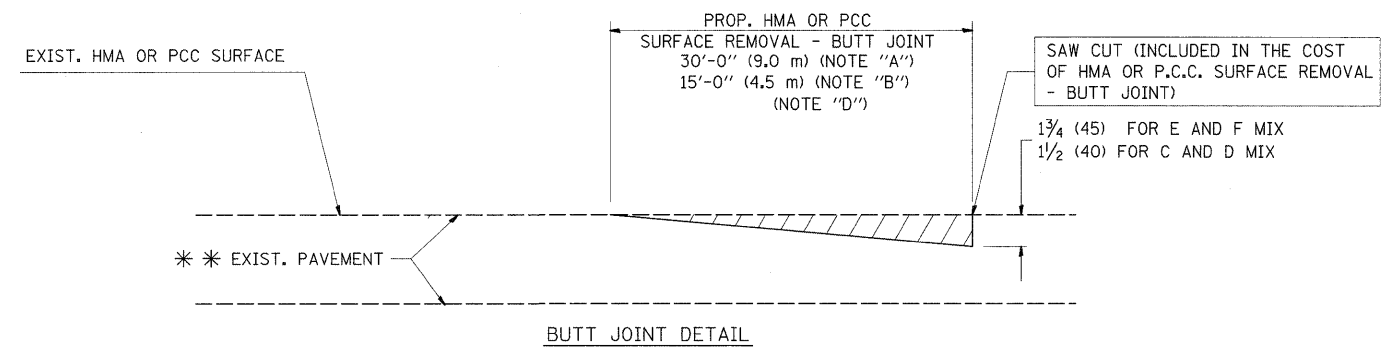

BUTT JOINT DETAIL

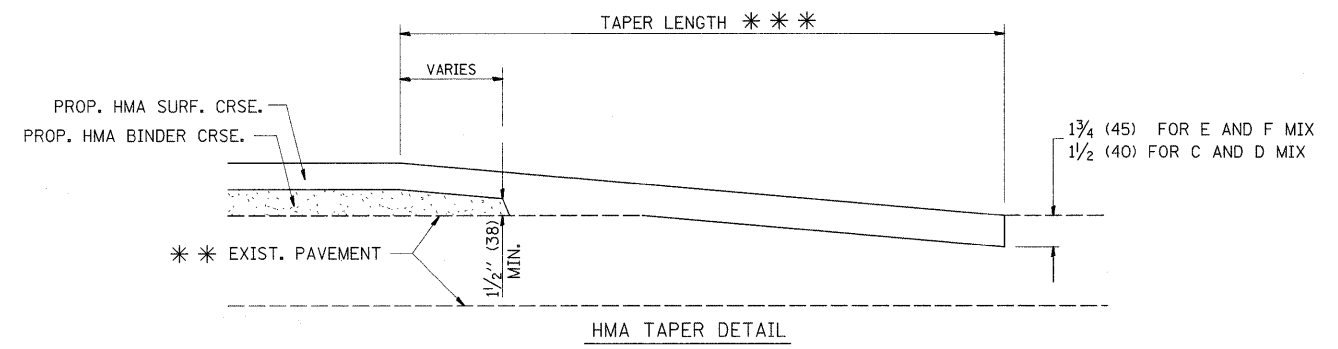

HMA TAPER DETAIL

TYPICAL BUTT JOINT AND HMA TAPER FOR RESURFACING ONLY

*** PC CONCRETE, HMA OR HMA RESURFACED PAVEMENT.

NOTES

- A: MAINLINE ROADWAYS AND MAJOR SIDE ROADS.
 - B: MINOR SIDE ROADS.
 - C: THE TEMP. RAMP SHALL BE CONSTRUCTED IMMEDIATELY UPON REMOVAL OF THE EXISTING HMA SURFACE.
 - D: THE BUTT JOINT SHALL BE CONSTRUCTED IMMEDIATELY PRIOR TO PLACING THE PROPOSED HMA COURSES.
 - E: TAPER THE TEMP. RAMP AT A RATE OF 3'-0" (900 mm) PER 1 INCH (25 mm) OF MILLING THICKNESS.
 - F: INSTALLATION AND REMOVAL OF THE 4'-6" (1.35 m) TEMP. RAMP IS INCLUDED IN COST OF HMA SURFACE REMOVAL - BUTT JOINT
 - G: SEE ARTICLE 406.08 AND 406.14 OF THE STANDARD SPECIFICATIONS FOR "HMA AND/OR PCC SURFACE REMOVAL, BUTT JOINT".
- * SEE TYPICAL SECTIONS FOR MILLING THICKNESS.
- *** 20'-0" (6.1 m) PER 1 (25) RESURFACING (NOTE "A")
10'-0" (3.0 m) PER 1 (25) RESURFACING (NOTE "B")

BASIS OF PAYMENT:

THE BUTT JOINT WILL BE PAID FOR AT THE CONTRACT UNIT PRICE PER SQUARE YARD (SQUARE METER) FOR "HOT-MIX ASPHALT SURFACE REMOVAL - BUTT JOINT" OR FOR "PORTLAND CEMENT CONCRETE SURFACE REMOVAL - BUTT JOINT".

ALL DIMENSIONS ARE IN INCHES (MILLIMETERS) UNLESS OTHERWISE SHOWN.

| | | | | | | | | | | | | |
|--|---------------------|-----------------------|-----------------------------|---|---|----------------|---------|---------------------------|---------|--------|--------------|-----------|
| FILE NAME = | USER NAME = abebawa | DESIGNED - M. DE YONG | REVISED - R. SHAH 10-25-94 | STATE OF ILLINOIS DEPARTMENT OF TRANSPORTATION | BUTT JOINT AND HMA TAPER DETAILS | | | F.A.I. RTE. | SECTION | COUNTY | TOTAL SHEETS | SHEET NO. |
| est\pwwork\pwwid01\ABEBAWA\0169692\0169692.dgn | | DRAWN - | REVISED - A. ABBAS 03-21-97 | | 55 | 99 (1&2) RS-11 | WILL | 45 | 36 | | | |
| PLOT SCALE = 50.0000' / IN. | | CHECKED - | REVISED - M. GOMEZ 04-06-01 | | BD400-05 BD32 | | | CONTRACT NO. 60153 | | | | |
| PLOT DATE = 12/23/2009 | | DATE - 06-13-90 | REVISED - R. BORO 01-01-07 | | FED. ROAD DIST. NO. 1 (ILLINOIS) FED. AID PROJECT | | | | | | | |
| | | | | SCALE: NONE | SHEET NO. 1 OF 1 SHEETS | STA. | TO STA. | | | | | |