

DIEBLE RD.
 STA. 6+50.00 TO STA. 8+49.75
 STA. 11+50.66 TO STA. 13+00.00

LEGEND - PROPOSED

- ① HMA SURFACE REMOVAL, 2"
- ② POLYMERIZED LEVELING BINDER (MM), IL-4.75, N50 (3/4")
- ③ POLYMERIZED HMA SURFACE COURSE, MIX "D", N50 (1 1/2")
- ④ URETHANE PAVEMENT MARKING
- ⑤ PREFORMED PLASTIC PVMT MARKING, TY B - LINE 6" (WHITE SKIP DASH)
- ⑥ HMA SHOULDERS
- ⑦ AGGREGATE SHOULDER, TYPE B

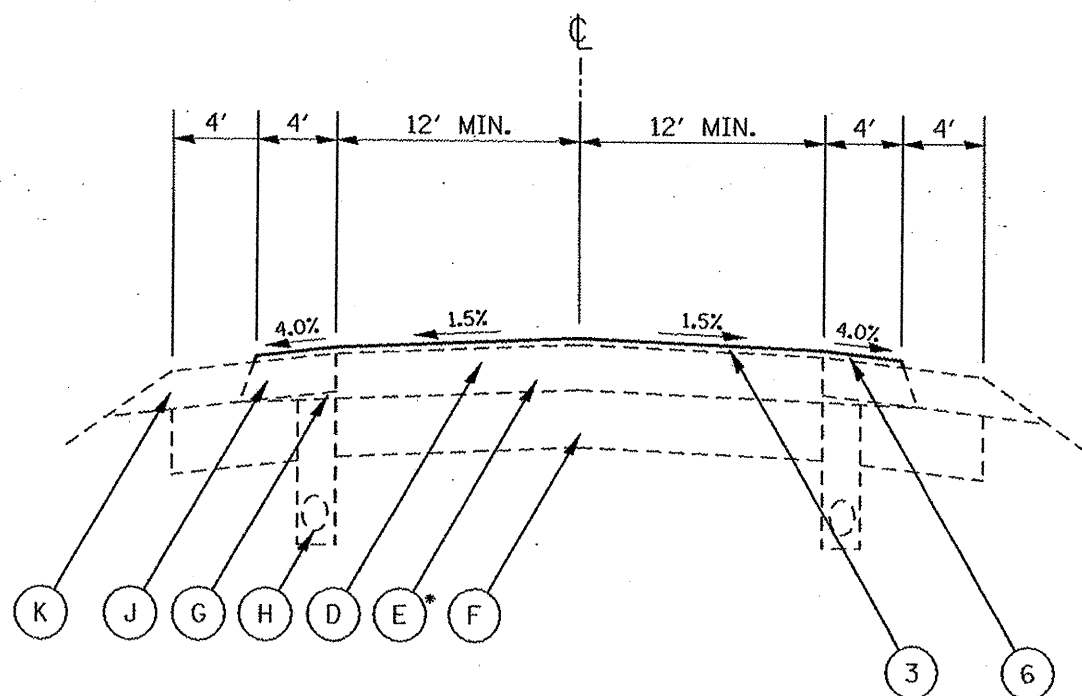

DIEBLE RD.
 STA. 8+49.75 TO STA. 9+80.95
 STA. 10+19.05 TO STA. 11+50.66
 *NOTE: HMA BASE CSE, 8"

LEGEND - EXISTING

- Ⓐ HMA PVMT (FULL-DEPTH), 14 1/4"
- Ⓑ HMA PVMT (FULL-DEPTH), 13"
- Ⓒ PCC BASE CSE, VAR.
- Ⓓ HMA SURFACE CSE, 1 1/2" AND VAR.
- Ⓔ HMA BASE CSE, 8" OR 10"
- Ⓕ LIME MODIFIED SUBGRADE, 12"
- Ⓖ SUB-BASE GRAN. MAT. TY C, VAR.
- Ⓗ PIPE UNDERDRAIN, 4"
- Ⓘ CONCRETE MEDIAN TY M-4
- Ⓙ HMA SHOULDER, 8"
- Ⓚ AGGREGATE SHOULDER, TY B, VAR.
- Ⓛ GUARDRAIL AGG. EROSION CONTROL OR EROSION CONTROL CURB

FILE NAME *	USER NAME = johnsonv	DESIGNED -	REVISED -
68467 - Phase 11.dgn		DRAWN -	REVISED -
		CHECKED -	REVISED -
		DATE -	REVISED -

**STATE OF ILLINOIS
 DEPARTMENT OF TRANSPORTATION**

TYPICAL SECTIONS

NOT TO SCALE SHEET NO. 7 OF 7 SHEETS

Rev. Sheet 2-11-10

F.A.P. RTE.	SECTION	COUNTY	TOTAL SHEETS	SHEET NO.
317	17RS-6; 18RS-1; 35RS-8	TAYLORVILLE WOODFORD	60	18
ILLINOIS FED. AID PROJECT			CONTRACT NO. 68467	