

MILLING TRANSITION DETAIL
STA 885+39 TO STA 885+69

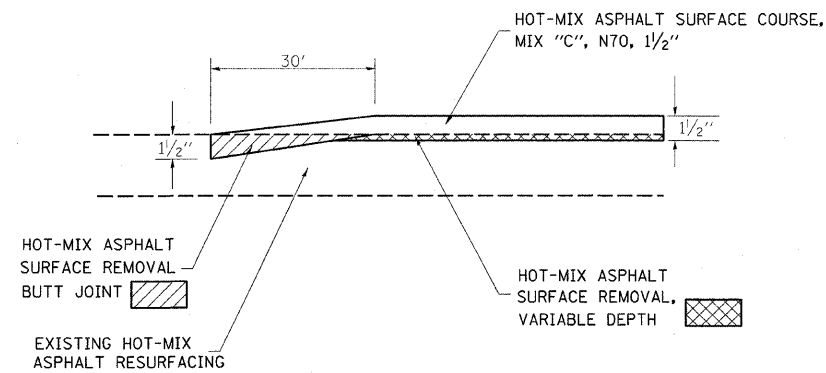

BUTT JOINT DETAIL
STA 655+75 TO STA 656+05
STA 846+51 TO STA 846+81
STA 847+85 TO STA 848+15

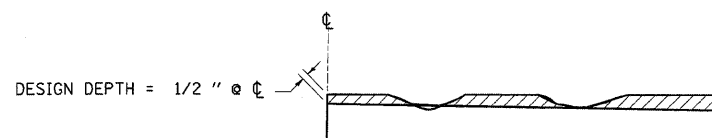

NOTES:

1. MILLING SHALL BE DONE TO ATTAIN A $\frac{3}{16}$ "' SLOPE IN CROWN SECTIONS
2. EXISTING S.E. AND S.E. TRANSITIONS SHALL BE MAINTAINED UNLESS OTHERWISE SHOWN ON THE PLANS.
3. MILLING TO THE BOTTOM OF WHEEL RUTS SHALL NOT BE NECESSARY UNLESS REQUIRED TO OBTAIN SLOPE OR THE DESIGN DEPTH AT CENTERLINE.
4. THE AVERAGE DEPTH OF MILLING IS ESTIMATED TO BE 1/2" BUT MAY VARY IN ISOLATED LOCATIONS.

HOT-MIX ASPHALT SURFACE REMOVAL (VARIABLE DEPTH) DETAIL

FILE NAME =	USER NAME = swartzw	DESIGNED -	REVISED - MMD 12-99	STATE OF ILLINOIS DEPARTMENT OF TRANSPORTATION	MILLING DETAILS		F.A.P. RTE.	SECTION	COUNTY	TOTAL SHEETS	SHEET NO.
c:\pwwork\pwwork\swartzw\d0147717\077418-sht-details.dgn	DRAWN -	REVISED -	832				4RS-1, 114RS-2	COLES	22	20	
PLOT SCALE = 100.0000' / IN.	CHECKED -	REVISED -	CONTRACT NO. 74418								
PLOT DATE = 11/24/2009	DATE -	REVISED -	SCALE: NA		SHEET NO. 1 OF 1 SHEETS	STA.	TO STA.	ILLINOIS FED. AID PROJECT			