

ROUTE NO.	SECTION	COUNTY	TOTAL SHEETS	SHEET NO.
F.A.S. 62	04-00164	STEPHENSON	15	7
C.H. 13	-00-BR			
ROAD DIST.	ILLINOIS	EAST PLUM RIVER		
Sheet 1 of 5			CONTRACT NO. 85419	

Note: Porous Granular Embankment is to be placed behind the abutment. The Porous Granular Embankment material shall be placed as shown directly under and for the full-width of the Aggregate Base Course of the approach roadway. Beyond the side limits of the Aggregate Base Course of the approach roadway, the Porous Granular Embankment material shall diminish in height from the full depth shown, utilizing a lateral slope of 1:1, to the bottom of the abutment cutoff wall at Elevation 99.52.

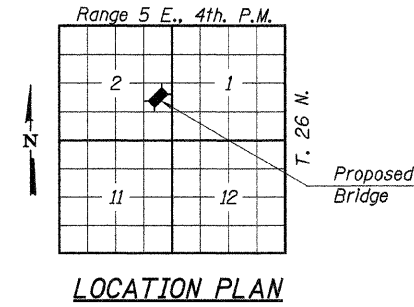

### GENERAL NOTES

- See Proposal Booklet for Boring data.
- Reinforcement bars shall conform to the requirements of ASTM A706 Grade 60. See Special Provisions.
- The Contractor shall drive one Steel HP12x53 test pile in a permanent location at the West abutment and at Pier #2 as directed by the Engineer, before ordering the remainder of piles.
- Layout of slope protection system may be varied in the field to suit ground conditions as directed by the Engineer.
- Protective Coat shall also be applied to deck fascias, exposed portions of wings, and ends of pier and abutment caps.
- All exposed portions of abutments, wingwalls, and piers shall receive a rubbed finish in accordance with Article 503.15(b) of the Standard Specifications. Cost to be included in the cost of Concrete Superstructure and Concrete Structures.
- The existing structural steel coating contains lead. The Contractor shall take appropriate precautions to deal with the presence of lead on this project.

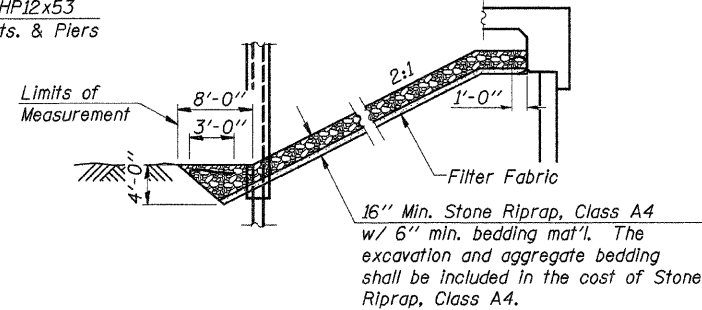
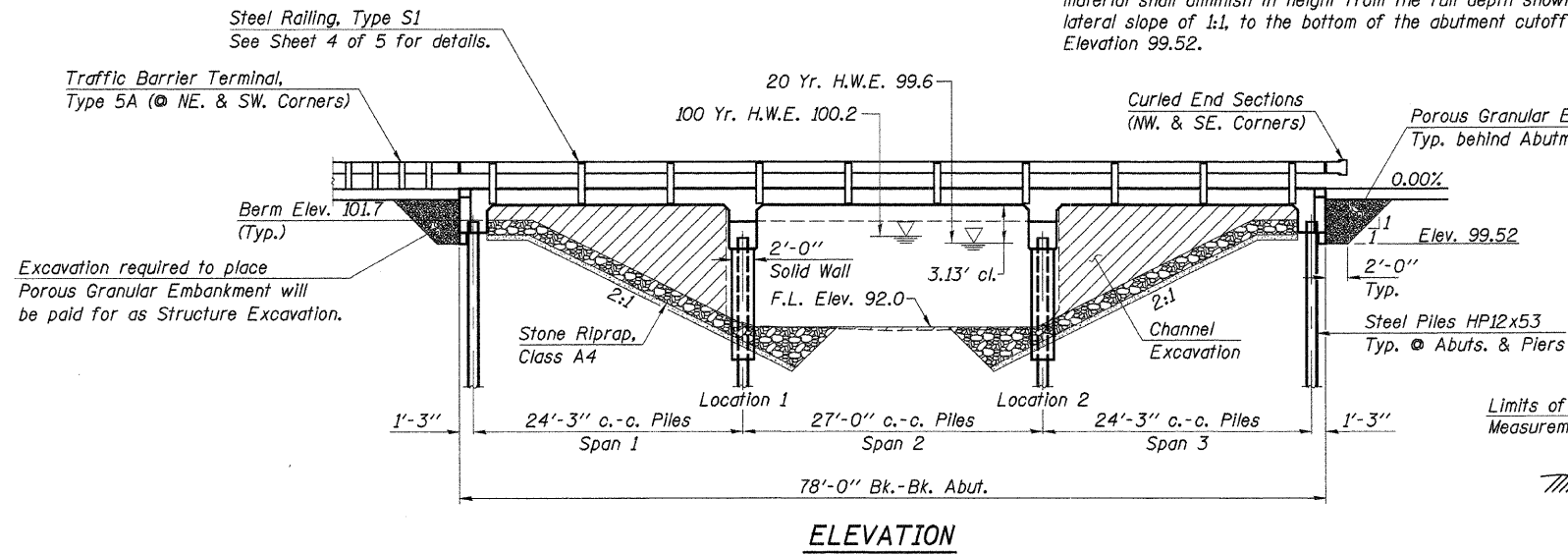

### SECTION A-A

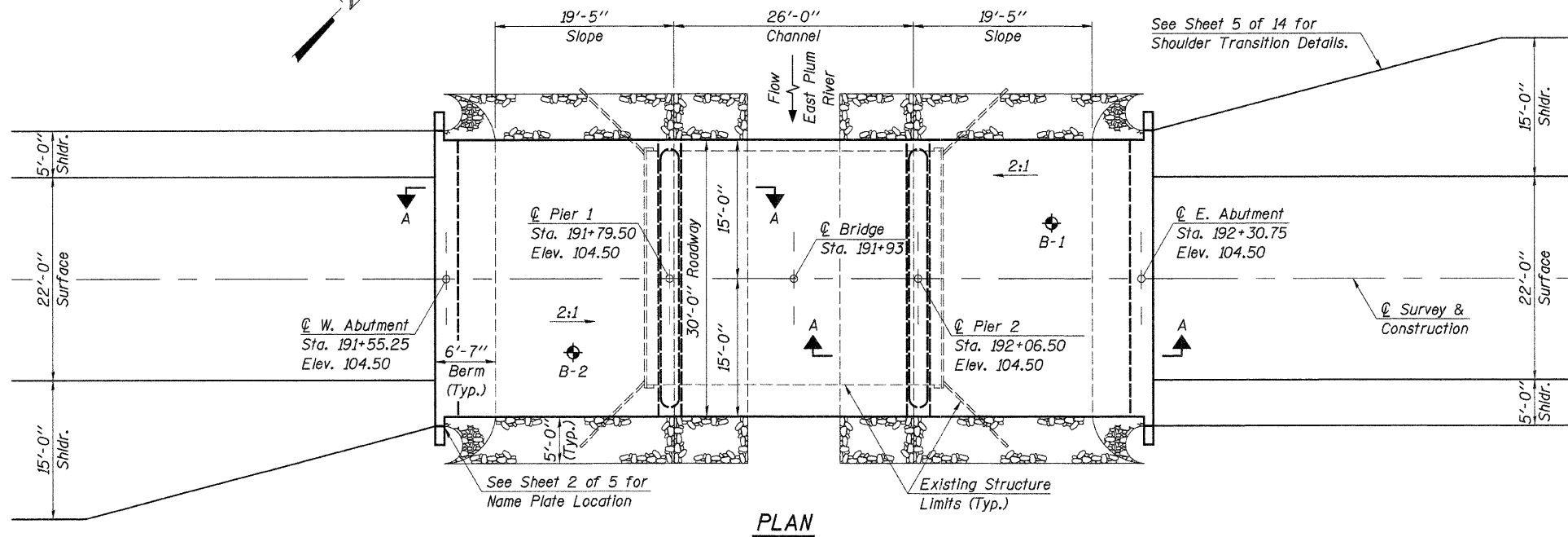

EAST PLUM RIVER  
BUILT 200\_ BY  
STEPHENSON COUNTY  
SEC. 04-00164-00-BR  
F.A.S. RT. 62 STA. 191+93  
STR. NO. 089-3281 LOADING HS20

LETTERING FOR NAME PLATE  
See Std. 515001

### TOTAL BILL OF MATERIAL

ITEM	UNIT	SUPER	SUB	TOTAL
Porous Granular Embankment	Ton		70	70
Stone Riprap, Class A4	Ton		232	232
Filter Fabric	Sq. Yd.		336	336
Structure Excavation	Cu. Yd.		64	64
Concrete Structures	Cu. Yd.		72.5	72.5
Concrete Superstructure	Cu. Yd.	114.9		114.9
Bridge Deck Grooving	Sq. Yd.	243		243
Protective Coat	Sq. Yd.	285	8	293
Reinforcement Bars, Epoxy Coated	Pound	25,620	8,760	34,380
Steel Railing, Type S1	Foot	156		156
Furnishing Steel Piles HP12X53	Foot		476	476
Driving Piles	Foot		476	476
Test Pile Steel HP12X53	Each		2	2
Name Plates	Each	1		1
Underwater Structure Excavation Protection - Location 1	Each		1	1
Underwater Structure Excavation Protection - Location 2	Each		1	1

### WATERWAY INFORMATION

Drainage Area	2.56 Sq. Mi.
Existing Opening (20 Yr.)	230 Sq. Ft.
Required Opening (20 Yr.)	282 Sq. Ft.
Proposed Opening (20 Yr.)	282 Sq. Ft.
Design Discharge (20 Yr.)	1,138 C.F.S.
Created Head (20 Yr.)	0.7 Ft.
100 Year Discharge	1,814 C.F.S.
100 Yr. Created Head	1.3 Ft.

### DESIGN STRESSES

$f'_c = 3,500$  p.s.i. (Concrete)  
 $f_y = 60,000$  p.s.i. (Reinforcement Bars)  
 $n = 8$   
 LOADING HS20-44  
 Design Specifications: 2002 AASHTO  
 25#/Sq. Ft. Included in dead load for  
 future wearing surface.

"I certify that to the best of my knowledge, information and belief, this bridge design is structurally adequate for the design loading shown on the plans. The design is an economical one for the style of structure and complies with requirements of the current 'AASHTO Standard Specifications for Highway Bridges'."

DESIGNED	A.R.K.
CHECKED	J.A.M.
DRAWN	S.A.P.
CHECKED	A.R.K. & J.A.M.

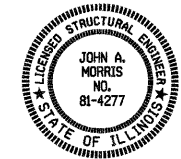

ILLINOIS STRUCTURAL NO. 4277 (Expires 11/30/10)

### GENERAL PLAN & ELEVATION

COUNTY HIGHWAY 13  
SECTION 04-00164-00-BR  
STEPHENSON COUNTY  
STATION 191+93

4440 ASH GROVE SPRINGFIELD, IL 62711 (217) 798-8800 www.fehr-graham.com	FEHR-GRAHAM & ASSOCIATES, LLC ENGINEERING AND SCIENCE CONSULTANTS FREEDOM, IL; ROCKFORD, IL; ROCKFORD, IL; SPRINGFIELD, IL	JOB NO.: 47188 FILE: 47188GPE.DGN DATE: 10/12/09
--	--	--