

SECTION C-C

\* Omit key on exterior face of outside beams

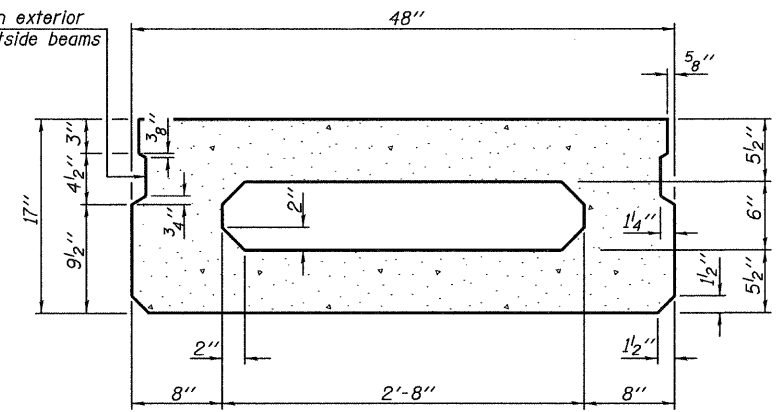

SECTION A-A (Showing dimensions)

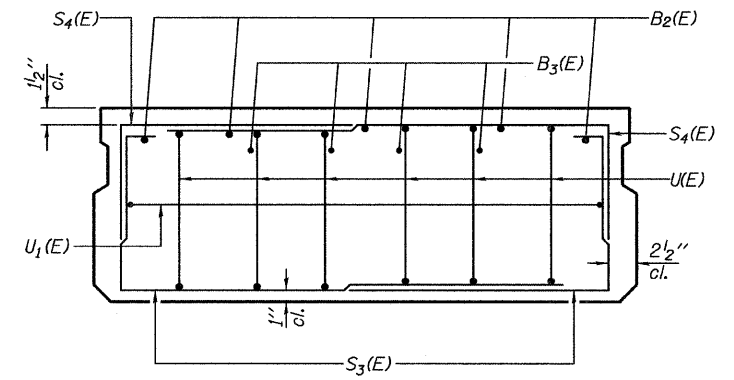

VIEW B-B

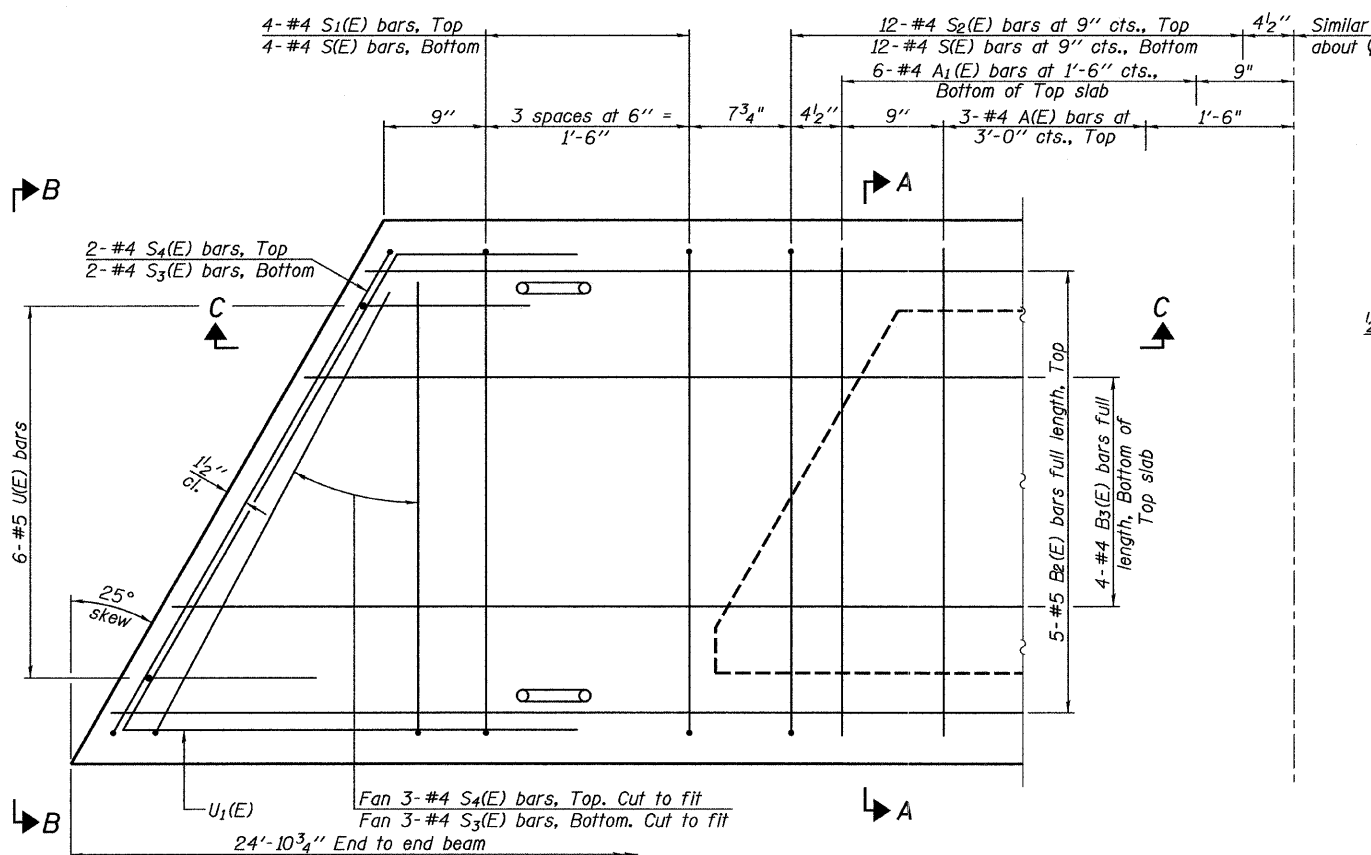

PLAN VIEW

Note: Spacing of S(E) and S2(E) bars may be adjusted up to 4" in the immediate area of the transverse tie diaphragms to miss the block outs for the transverse ties.

\* Rail Post Anchor Devices to be cast into Exterior Face of Outside Beams

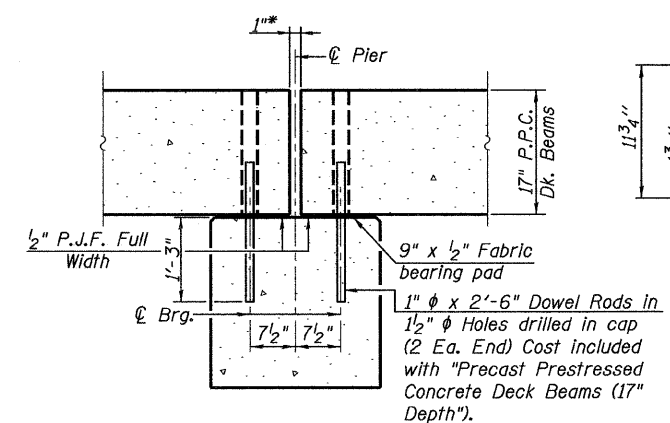

SECTION THRU PIER

Notes: After beams have been erected, holes shall be drilled into substructure and anchor dowels placed. Dowel holes shall be filled with non-shrink grout to top of beam and allowed to cure min. 24 hrs. prior to grouting the shear keys.  
All horizontal dimensions are at right angles to beam ends. Hatched area to be poured after beams are in place.  
\* 1" joint shall be filled with non-shrink grout. 1" dimension may vary to accommodate tolerance in beam lengths.

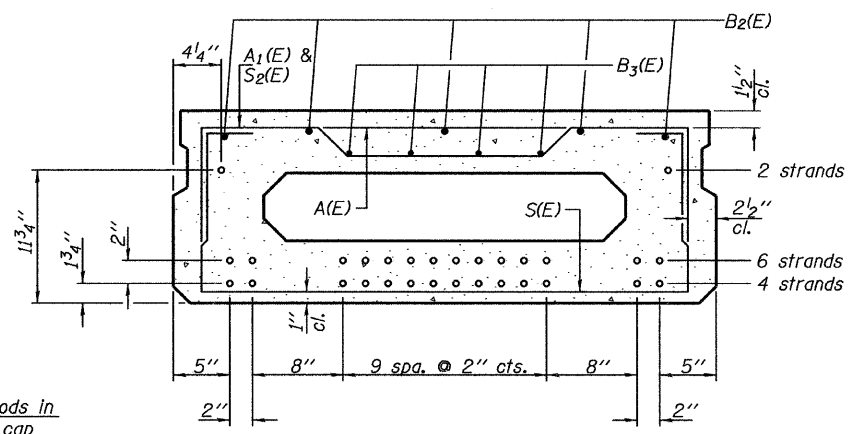

SECTION A-A (Showing reinforcement and permissible strand locations)

Note: Place the number of strands specified in each row symmetrically about the centerline of beam in the permissible strand locations shown.

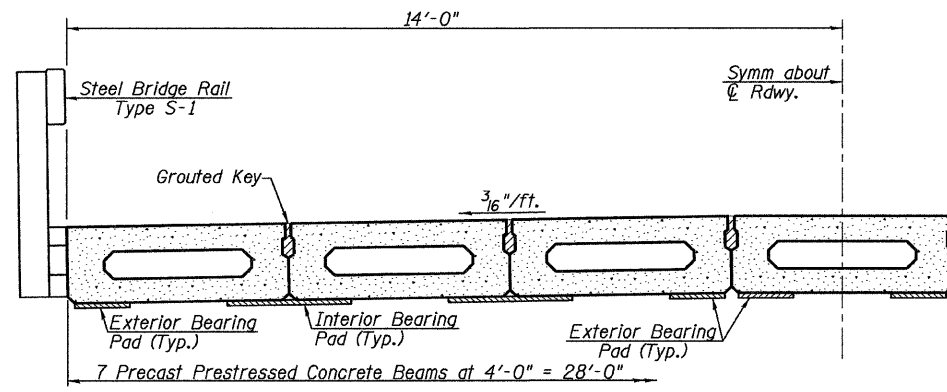

HALF CROSS SECTION

BAR LIST ONE BEAM ONLY (For information only)

Bar	No.	Size	Length	Shape
A(E)	6	#4	3'-7"	—
A1(E)	12	#4	3'-10"	—
B2(E)	5	#5	24'-7"	—
B3(E)	4	#4	24'-7"	—
S(E)	32	#4	6'-9"	□
S1(E)	8	#4	5'-3"	□
S2(E)	24	#4	5'-6"	□
S3(E)	10	#4	5'-2"	□
S4(E)	10	#4	4'-5"	□
U1(E)	12	#5	3'-8"	□
U1(E)	2	#4	8'-2"	□

Note: See sheet 9 of 17 for additional details and Bill of Material.

PD-1748-L

10-1-08

FILE NAME =	USER NAME = #USER#	DESIGNED -	REVISED -	<p>Allen Henderson &amp; Associates, Inc. Civil and Structural Engineers Springfield, IL 62703 Phone: (217)544-8033 IL Design Firm No. 184-001907</p>	<p><b>SUPERSTRUCTURE (SPAN 2)</b></p>	T.R. RTE.	SECTION	COUNTY	TOTAL SHEETS	SHEET NO.
#FILE#	DRAWN -	REVISED -	166			08-10110-00-BR	MENARD	17	8	
PLOT SCALE = #SCALE#	CHECKED -	REVISED -	CONTRACT NO. 93510							
PLOT DATE = #DATE#	DATE -	REVISED -	SCALE: NONE			SHEET NO. 8 OF 17 SHEETS	STA. TO STA.	FED. ROAD DIST. NO.	ILLINOIS FED. AID PROJECT	