

STATE OF ILLINOIS  
DEPARTMENT OF TRANSPORTATION

Notch formed by rough finished board attached to and removed with form work, each interior wall. (Do not chamfer).

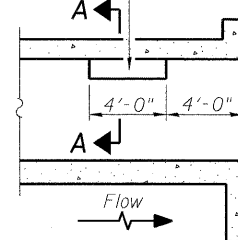

LONGITUDINAL SECTION

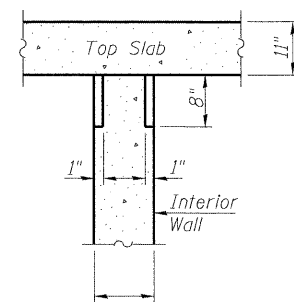

SECTION A-A

PHOEBE NESTING  
SITE DETAILS  
(Downstream End Only)

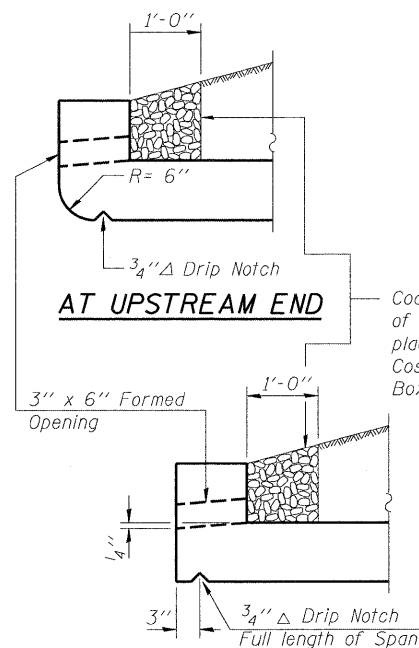

AT UPSTREAM END

AT DOWNSTREAM END

DRAIN DETAIL

Coarse aggregate full length of both headwalls. To be placed by Grading Contractor. Cost included with Concrete Box Culverts.

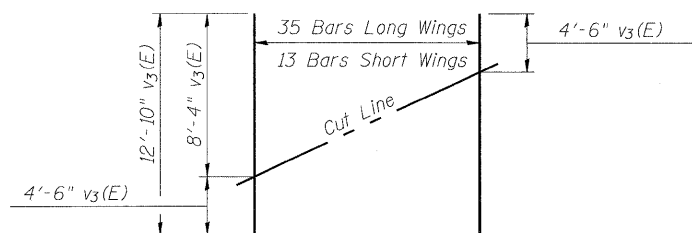

FIELD CUTTING DIAGRAM

Order v3(E) full length. Cut as shown and use remainder of bars in opposite wing.

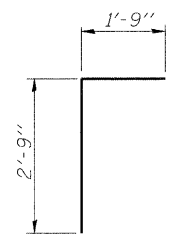

BAR d(E)

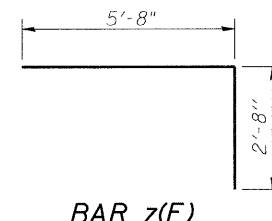

BAR z(E)

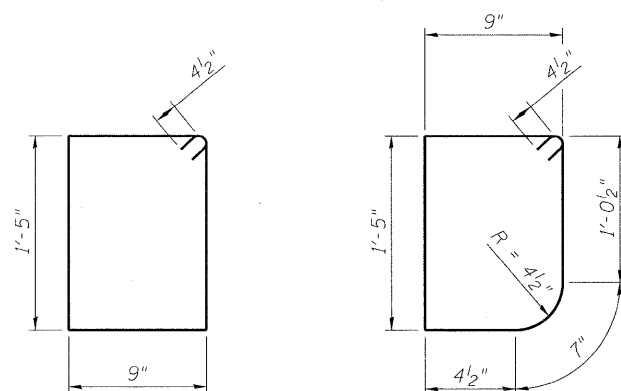

BAR s1(E)

BAR s(E)

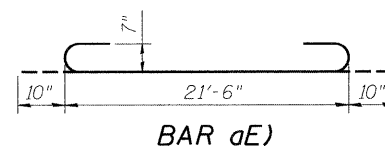

BAR a(E)

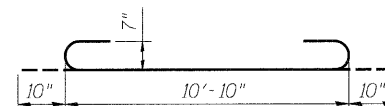

BAR a1(E)

BILL OF MATERIAL

Bar	No.	Size	Length	Shape
a(E)	232	#7	23'-2"	U
a1(E)	496	#7	12'-6"	U
a2(E)	110	#8	10'-6"	—
a3(E)	40	#4	21'-6"	—
a4(E)	70	#4	10'-10"	—
d(E)	66	#4	4'-6"	L
h(E)	22	#7	45'-6"	—
h1(E)	22	#7	34'-0"	—
h2(E)	44	#7	36'-0"	—
h3(E)	35	#6	45'-6"	—
h4(E)	35	#6	34'-0"	—
h5(E)	30	#5	45'-6"	—
h6(E)	30	#5	34'-0"	—
h7(E)	64	#5	35'-0"	—
h8(E)	12	#7	17'-0"	—
h9(E)	36	#7	33'-6"	—
h10(E)	6	#4	33'-6"	—
h11(E)	6	#4	17'-0"	—
h12(E)	24	#4	22'-9"	—
h13(E)	24	#4	8'-0"	—
h14(E)	64	#6	35'-3"	—
s(E)	49	#4	4'-11"	0
s1(E)	181	#4	5'-1"	0
v(E)	722	#4	8'-7"	—
v1(E)	96	#4	4'-9"	—
v2(E)	8	#4	11'-5"	—
v3(E)	48	#4	12'-10"	—
w(E)	16	#5	27'-0"	—
w1(E)	16	#5	11'-3"	—
z(E)	108	#7	8'-4"	L
Concrete Box Culverts			Cu. Yd.	353.0
Reinforcement Bars, Epoxy Coated			Pound	58,970

BOX CULVERT DETAILS

GORDON DRIVE OVER  
GRINDSTONE CREEK

F.A.U. 8153 - SEC. 09-00028-01-DR

SANGAMON COUNTY

STATION 41+97.55

STRUCTURE NO. 084-8011

SHEET NO. 8	F.A.U. RTE.	SECTION	COUNTY	TOTAL SHEETS	SHEET NO.
9 SHEETS	8153	09-00028-01-DR	SANGAMON	32	20
FED. ROAD DIST. NO. -			ILLINOIS	FED. AID PROJECT	ARA-5082(009)
					CONTRACT NO. 93516



DESIGNED NIEWINSKI  
CHECKED TRELLO  
DRAWN VERENSKI  
CHECKED TRELLO