

PRIVATE ENTRANCE SCHEDULE

UNION COUNTY
SECTION 09-0098-00-RS
PROJECT NO. ARA-0926(112)
SHEET 6 OF 7

LOCATION	WIDTH	BIT. TONS
PEL 27 + 06	15'	2.5
PER 39 + 83	15	2.5
PER 53 + 88	15'	2.5
PER 55 + 13	15'	2.5
PEL 68 + 10	15'	2.5
PER 68 + 57	15'	2.5
PEL 73 + 45	15'	2.5
PER 74 + 68	175' x 10'	*
PEL 82 + 47	18'	2.85
PEL 83 + 42	15'	2.5
PER 102 + 75	20'	3.09
PEL 103 + 18	20'	3.09
PER 103 + 62	15'	2.5
PEL 122 + 02	15'	2.5
PER 123 + 20	15'	2.5
PER 142 + 94	15'	2.5
PER 169 + 60	15'	2.5
PER 187 + 24	18'	2.85
PEL 189 + 51	18'	2.85
PEL 191 + 53	15'	2.5
PEL 191 + 64	15'	2.5
PEL 216 + 47	30'	4.25
PER 220 + 35	15'	2.5

LOCATION	WIDTH	BIT. TONS
PEL 221 + 40	15'	2.5
PEL 223 + 28	15'	2.5
PEL 224 + 46	15'	2.5
PEL 226 + 29	15'	2.5
PEL 230 + 49	15'	2.5
PER 231 + 11	15'	2.5
PEL 233 + 49	15'	2.5
PEL 235 + 05	18'	2.85
PEL 238 + 80	15'	2.5
PEL 244 + 61	15'	2.5
PEL 245 + 36	15'	2.5
PEL 248 + 35	15'	2.5
PEL 249 + 25	15'	2.5
PEL 251 + 82	15'	2.5
PEL 257 + 16	15'	2.5
PER 258 + 97	15'	2.5
PER 260 + 87	15'	2.5
PER 262 + 42	30'	4.25
PEL 262 + 65	100'	12.42
PER 263 + 08	15'	2.5
PEL 263 + 68	18'	2.85
PER 263 + 85	18'	2.85
PEL 266 + 05	38'	5.19
PER 266 + 48	18'	2.85

LOCATION	WIDTH	BIT. TONS
PER 268 + 89	20'	3.09
PER 271 + 89	18'	2.85
PER 274 + 70	15'	2.5
PEL 282 + 38	15'	2.5
PER 283 + 37	BUTT AGAINST EXIST. DRIVEWAY	
PER 285 + 44	15'	2.5
PEL 286 + 10	20'	3.09
PEL 286 + 29	15'	2.5
PER 291 + 26	15'	2.5
PER 291 + 49	15'	2.5
PEL 291 + 93	15'	2.5
PEL 293 + 32	18'	2.85
PER 295 + 34	15'	2.5
PER 297 + 88	15'	2.5
PER 299 + 73	15'	2.5

* QUANTITY INCLUDED IN AGG. SHOULDERS, TYPE B

NOTE - AGGREGATE QUANTITIES FOR 43 FIELD ENTRANCES AND 37 MAIL BOX TURNOUTS ARE INCLUDED IN AGGREGATE SHOULDERS, TYPE B.

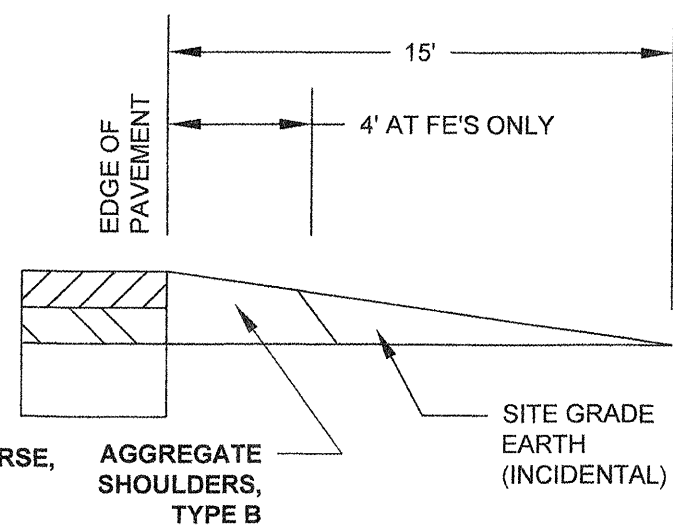
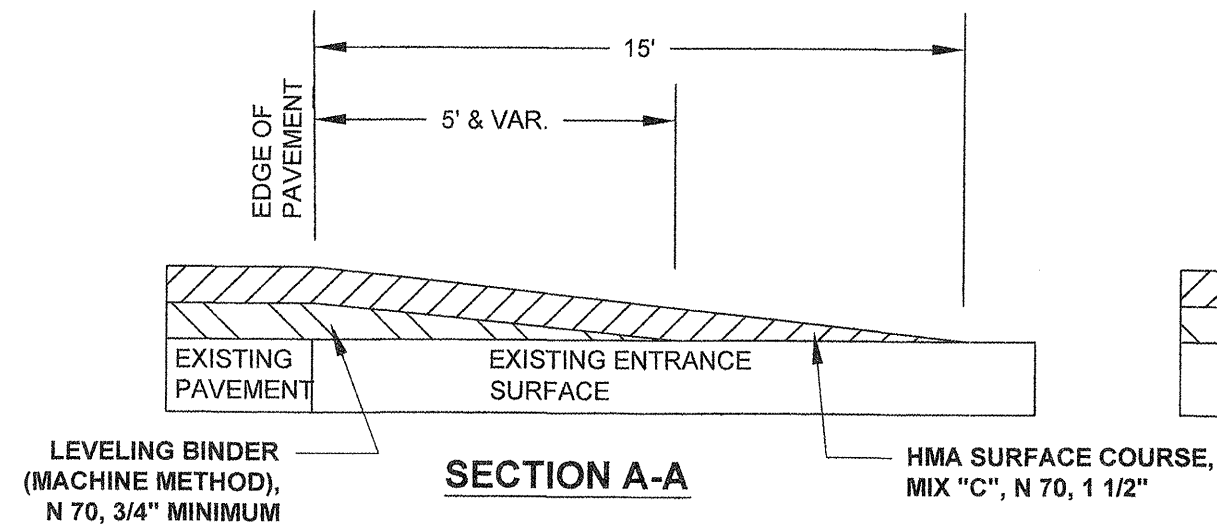
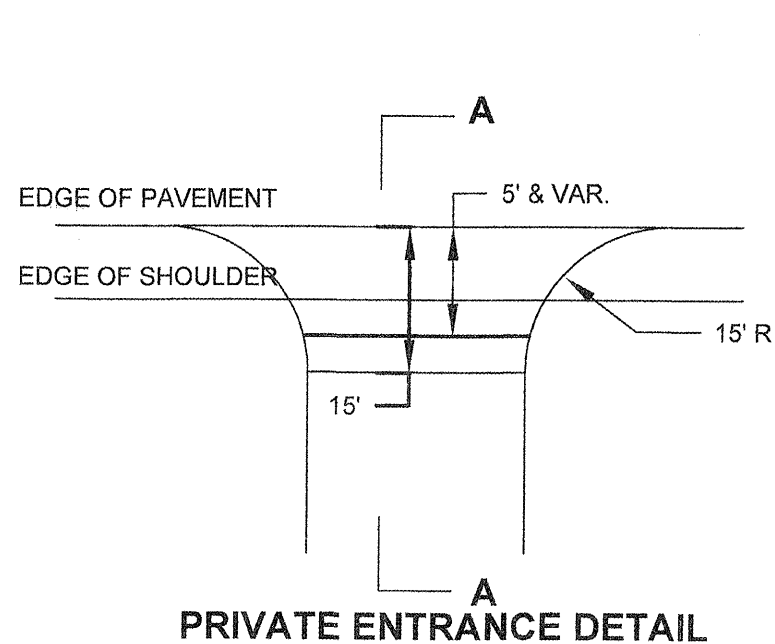

TYPICAL ENTRANCE DETAILS

(NOT TO SCALE)