

STATE OF ILLINOIS
DEPARTMENT OF TRANSPORTATION

F.A. RTE.	SECTION	COUNTY	TOTAL SHEETS	SHEET NO.
VAR	D4 GUARDRAIL REPAIRS 2021-MCHD	VARIOUS	27	1
		ILLINOIS	CONTRACT NO. 68F96	

INDEX OF SHEETS:

- 1 COVER SHEET
- 2 JOB SPECIFIC NOTES & COMMITMENTS
- 3-6 SUMMARY OF QUANTITIES
- 7 SAMPLE WORK FORM
- 8 EXISTING V.A.T. SYSTEM
- 9 PROPOSED C.A.T. SYSTEM
- 10-12 EXISTING TRAFFIC BARRIER, TERMINAL TYPE 3 & TYPE 3A
- 13-14 EXISTING TYPE 4 TERMINAL
- 15-17 EXISTING CABLE MEDIAN BARRIER (CABLE ROAD GUARD)
- 18 EXISTING GIBRALTAR CABLE BARRIER DETAIL
- 19 EXISTING TRAFFIC BARRIER TERMINAL TYPE 8
- 20 EXISTING TRAFFIC BARRIER TERMINAL TYPE 9
- 21-23 EXISTING TUBULAR THRIE BEAM RETROFIT RAIL FOR BRIDGES
- 24-27 STEEL PLATE BEAM GUARDRAIL, TYPE A, 6.75 FOOT POSTS STANDARD 630011-D4

PROPOSED HIGHWAY PLANS

VARIOUS ROUTES
SECTION D4 GUARDRAIL REPAIRS 2021-MCHD
PROJECT
CONTRACT MAINTENANCE
TYPE of IMPROVEMENT
VARIOUS COUNTIES

HIGHWAY STANDARDS:

630001-12	631046-04	701201-05	701456-05
630101-10	635001-02	701301-04	701601-09
630301-09	664001-02	701400-10	701606-10
631006-08	665001-02	701406-12	701701-10
631011-10	701006-05	701411-09	701901-08
631026-06	701011-04	701428-01	BLR-23-04
631031-17	701101-05		

DISTRICT STANDARDS:

630011-D4

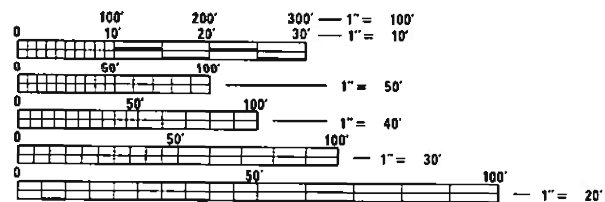

FULL SIZE PLANS HAVE BEEN PREPARED USING STANDARD ENGINEERING SCALES. REDUCED SIZED PLANS WILL NOT CONFORM TO STANDARD SCALES. IN MAKING MEASUREMENTS ON REDUCED PLANS, THE ABOVE SCALES MAY BE USED.

J.U.L.I.E.
JOINT UTILITY LOCATION INFORMATION FOR EXCAVATION
1-800-892-0123
OR 811

PROJECT ENGINEER RICH DOTSON (309) 671-3455
PROJECT MANAGER MIKE JACOBS (309) 671-3460
CATALOG NO. 036099-00D
CONTRACT NO. 68F96

GROSS LENGTH = N/A
NET LENGTH = N/A

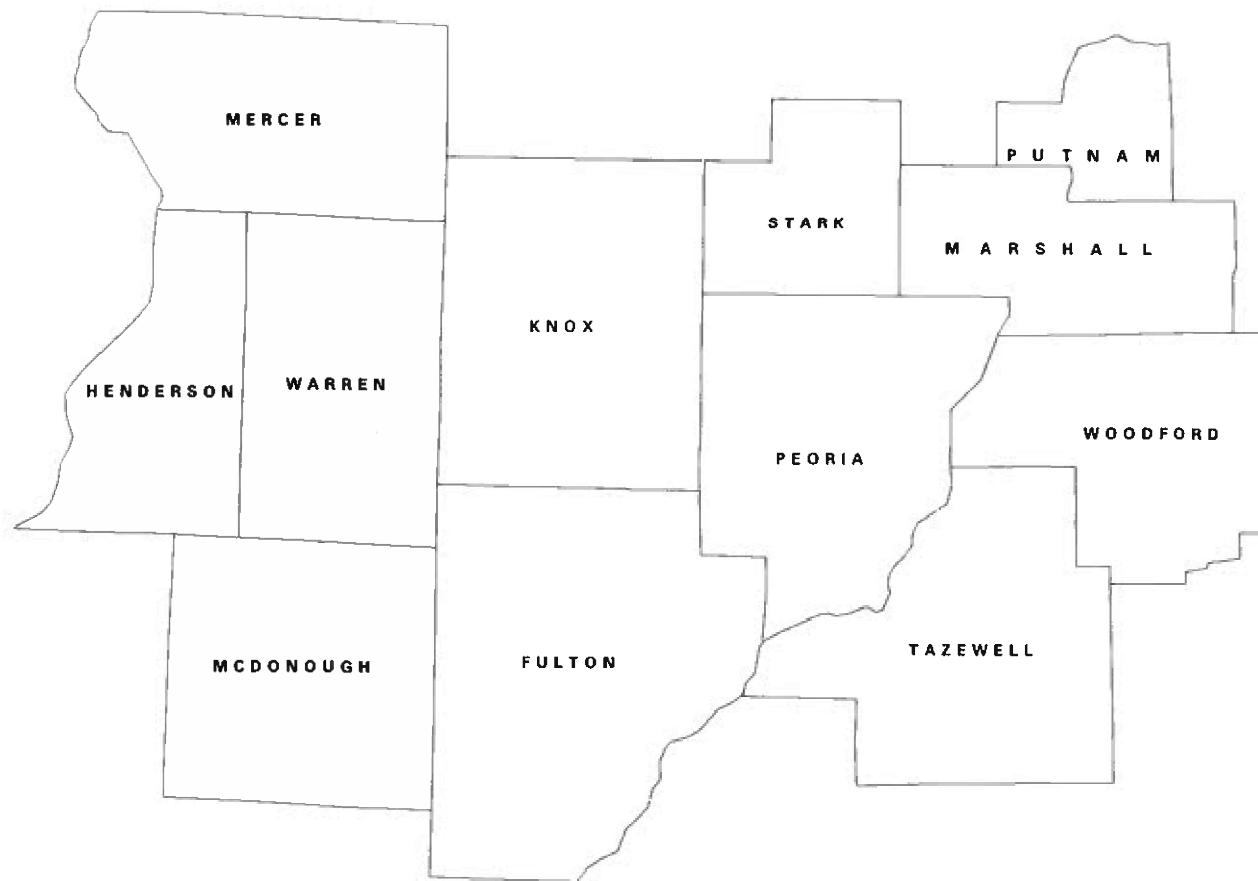

D-94-085-20

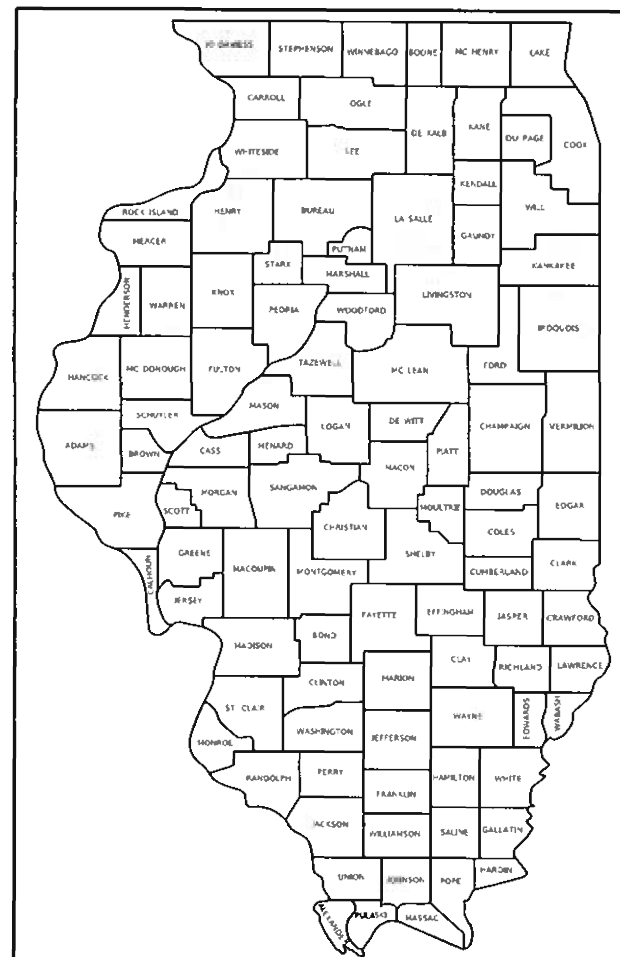

LOCATION OF SECTION INDICATED THUS: - [black rectangle]

DESCRIPTION:
GUARDRAIL REPAIRS CAUSED BY MOTORISTS
AND CABLE GAURDRAIL REPAIRS AT
VARIOUS LOCATIONS IN DISTRICT 4

STATE OF ILLINOIS
DEPARTMENT OF TRANSPORTATION

SUBMITTED Dec 16 20 20
Kensie A Barnett xss
REGIONAL ENGINEER

January 29, 2021
[Signature]
ENGINEER OF DESIGN AND ENVIRONMENT

January 29, 2021
[Signature]
DIRECTOR OF HIGHWAYS PROJECT IMPLEMENTATION 13

PRINTED BY THE AUTHORITY
OF THE STATE OF ILLINOIS

COMMITMENTS

NO COMMITMENTS HAVE BEEN MADE FOR THIS PROJECT.

TRAFFIC BARRIER TERMINAL, TYPE 1 SPECIAL:

ANY TYPE 1, 1A, OR 1B TERMINAL REQUIRING REPLACEMENT UNDER THIS CONTRACT SHALL BE REPLACED BY A TYPE 1 (SPECIAL) TERMINAL AS DIRECTED BY THE ENGINEER.

THE CONTRACTOR SHALL NOTIFY THE RESIDENT ENGINEER FORTY-EIGHT (48) HOURS PRIOR TO PERFORMING WORK.

MODEL: Default
 FILE: \\nls-px1uplanroom\data\illinois.gov\PI\DOT\Documents\DOT_Offices\District_4\Projects\ID4_68F96\CADD\3a\CAD\Drawings\ID4xxxx-CADD.dgn

USER NAME = letemowe	DESIGNED -	REVISED -
	DRAWN -	REVISED -
PLOT SCALE = 40.0000 ' / in.	CHECKED -	REVISED -
PLOT DATE = 12/8/2020	DATE -	REVISED -

**STATE OF ILLINOIS
 DEPARTMENT OF TRANSPORTATION**

JOB SPECIFIC NOTES AND COMMITMENTS

SCALE: SHEET OF SHEETS STA. TO STA.

F.A. RTE.	SECTION	COUNTY	TOTAL SHEETS	SHEET NO.
VAR	D4 GUARDRAIL REPAIRS 2021-MCHD	VARIOUS	27	2
			CONTRACT NO. 68F96	
			ILLINOIS FED. AID PROJECT	

MODEL:\D:\ef\aut FILE:\NEW\PA\1\bar\com\des\illinois\sup\1\DOT\Documents\1\DOT -Of\ices\District 4\Projects\04-66F96\CADData\CADDrawings\04xxxxx-CAD00.dgn

CODE NO.	ITEM	UNIT	TOTAL QUANTITY	CONSTRUCTION CODE		
				VARIOUS COUNTIES	VARIOUS COUNTIES	VARIOUS COUNTIES
				100 % STATE	100 % STATE	100 % STATE
				MCHD 0021	CONT. MAINT. 0021	HTMCB 0021
64300370	IMPACT ATTENUATORS (FULLY REDIRECTIVE, WIDE), TEST LEVEL 3	EACH	2	1	1	
64300450	IMPACT ATTENUATORS (NON- REDIRECTIVE), TEST LEVEL 3	EACH	4	3	1	
64300770	IMPACT ATTENUATORS (SEVERE USE, NARROW), TEST LEVEL 3	EACH	2	1	1	
66400105	CHAIN LINK FENCE, 4'	FOOT	7	5	2	
66400305	CHAIN LINK FENCE, 6'	FOOT	480	360	120	
66500105	WOVEN WIRE FENCE, 4'	FOOT	500	350	150	
* 72501000	TERMINAL MARKER - DIRECT APPLIED	EACH	40	28	12	
* 78200005	GUARDRAIL REFLECTORS, TYPE A	EACH	20	14	6	
X0301372	REPAIR/UPGRADE EXISTING VAT TO CAT	EACH	6	4	2	
X0320013	REPAIR IMPACT ATTENUATORS (FULLY REDIRECTIVE, WIDE), TEST LEVEL 3	EACH	1	1		
X0320014	REPAIR IMPACT ATTENUATORS (SEVERE USE, NARROW), TEST LEVEL 3	EACH	1	1		
X0325264	REPAIR IMPACT ATTENUATORS (FULLY REDIRECTIVE, NARROW), TEST LEVEL 3	EACH	5	2	3	
X0325899	REPAIR HIGH TENSION CABLE (GIBALTAR)	FOOT	500			500
X0325900	REPAIR HIGH TENSION BARRIER TERMINAL (GIBALTAR)	EACH	2			2

*= SPECIALTY ITEM

USER NAME = letemove	DESIGNED -	REVISED -
	DRAWN -	REVISED -
PLOT SCALE = 48.0000' / in.	CHECKED -	REVISED -
PLOT DATE = 12/8/2020	DATE -	REVISED -

**STATE OF ILLINOIS
DEPARTMENT OF TRANSPORTATION**

SUMMARY OF QUANTITIES

F.A. RTE.	SECTION	COUNTY	TOTAL SHEETS	SHEET NO.
VAR	D4 GUARDRAIL REPAIRS 2021-MCHD	VARIOUS	27	4
			CONTRACT NO. 68F96	
ILLINOIS FED. AID PROJECT				

ILLINOIS DEPT OF TRANSPORTATION - DIST 4 - WORK ORDER

TO: _____

D/A: _____

MOTORIST-CAUSED DAMAGE REPAIR

FY

JOB NUM: _____

CONTRACT NUM: _____

CLAIM NUM: _____

ROAD: _____ LOCATION: _____ COUNTY: _____

<u>CODE NUM</u>	<u>ITEM</u>	<u>UNIT</u>	<u>QTY</u>	<u>UNIT PRICE</u>	<u>AMOUNT</u>
-----------------	-------------	-------------	------------	-------------------	---------------

TOTAL CHARGES (This Work Order)\$

SPECIAL INSTRUCTIONS:

WORK ORDER ISSUED: _____ BY: _____ ACCEPTED: _____ BY: _____

WORK ORDER COMPLETED: _____ DATE: _____

I/WE CERTIFY WORK HAS BEEN PERFORMED ACCORDING TO THE CONTRACT AND HEREBY REQUEST

PAYMENT: _____ BY: _____ ACCEPTED: _____ BY: _____

VERIFICATION OF WORK ORDER COMPLETED: _____ BY: _____

APPROVED FOR PAYMENT

DATE

FILE NAME =	USER NAME = letemove	DESIGNED -	REVISED -	STATE OF ILLINOIS DEPARTMENT OF TRANSPORTATION	DISTRICT 4 - SAMPLE WORK ORDER	F.A. RTE.	SECTION	COUNTY	TOTAL SHEETS	SHEET NO.	
pw\planroom.dot.illinois.gov\PIDOT\Documents\IDOT Offices\District 4\Projects\D4.68F\Drawings\CADD\Drawings\D4xxxx-CADD.dgn		CHECKED -	REVISED -			VAR	D4 GUARDRAIL REPAIRS 2021-MCHD	VARIOUS	27	7	
Default	PLOT SCALE = 40.0000' / in.	DATE -	REVISED -			CONTRACT NO. 68F96					
	PLOT DATE = 12/8/2020					SCALE:	SHEET 1	OF 1	SHEETS	STA.	TO STA.

**DETAIL INCLUDED
FOR REPAIR ONLY**

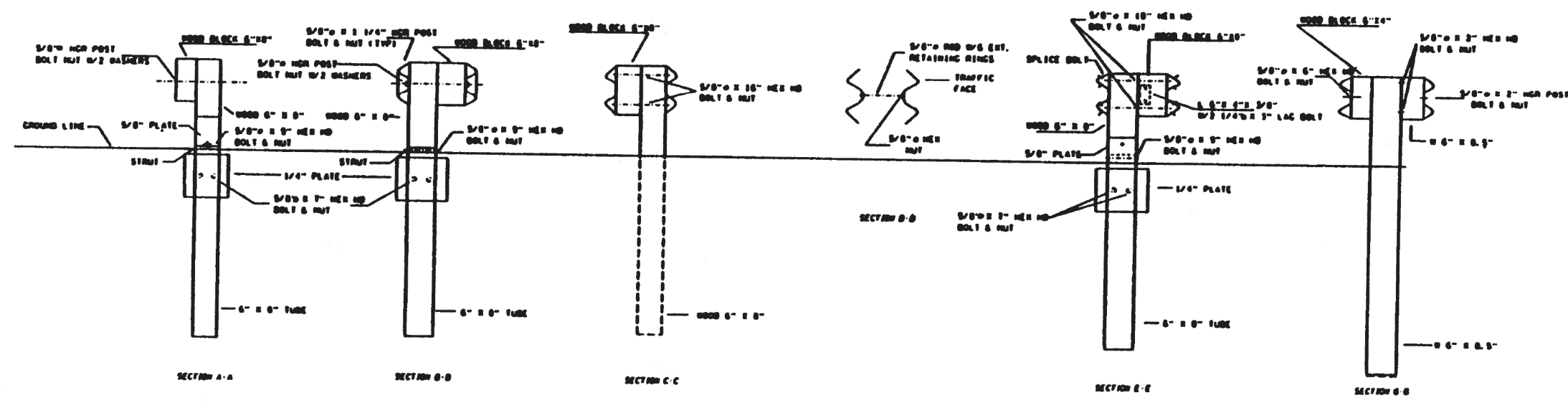
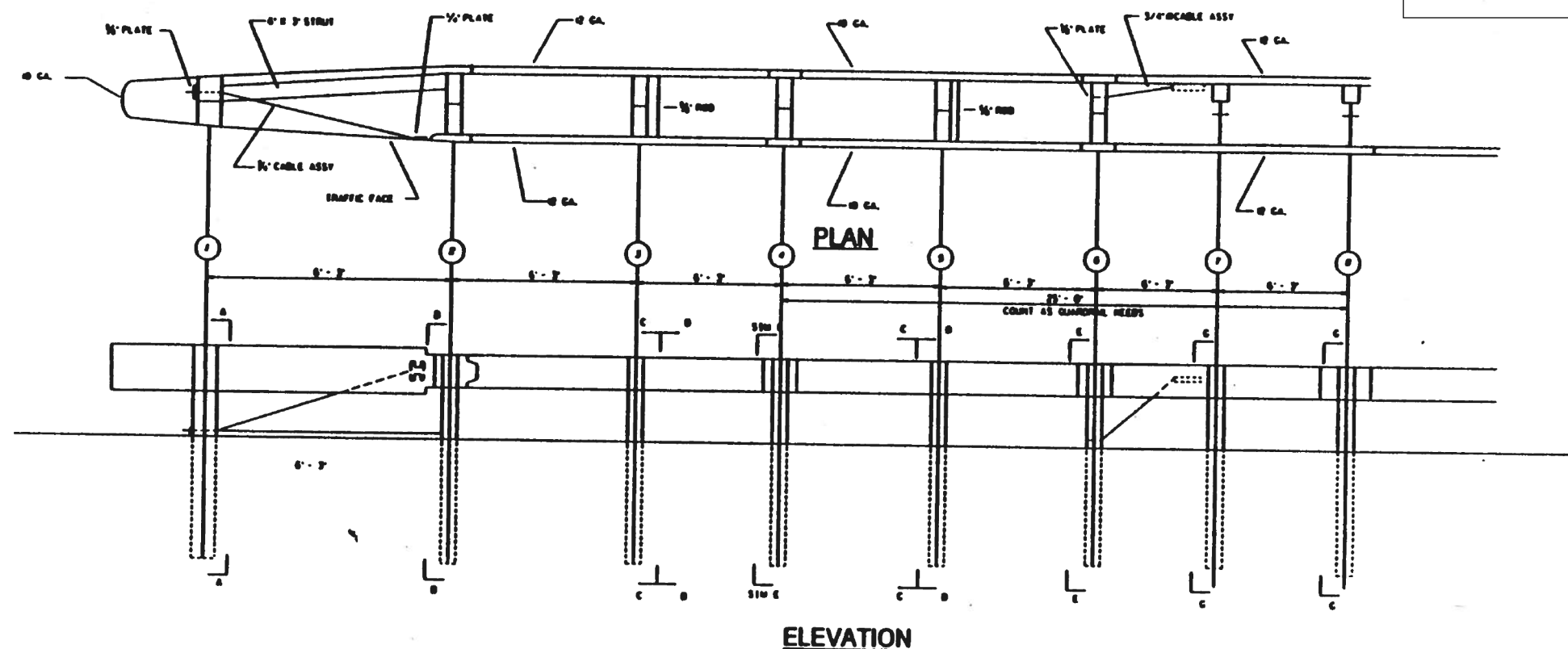

FILE NAME =	USER NAME = letemove	DESIGNED -	REVISED -
pw\planroom.dot.illinois.gov\PIWIDOT\Documents\IDOT Offices\District 4\Projects\D4.68\Drawings\CADD\Drawings\D4xxxx-CADD.dgn		DRAWN -	REVISED -
Default	PLOT SCALE = 48.0000' / in.	CHECKED -	REVISED -
	PLOT DATE = 12/8/2020	DATE -	REVISED -

**STATE OF ILLINOIS
DEPARTMENT OF TRANSPORTATION**

EXISTING V.A.T. SYSTEM
SCALE: SHEET 1 OF 1 SHEETS STA. TO STA.

F.A. RTE.	SECTION	COUNTY	TOTAL SHEETS	SHEET NO.
VAR	D4 GUARDRAIL REPAIRS 2021-MCHD	VARIOUS	27	8
			CONTRACT NO. 68F96	
ILLINOIS FED. AID PROJECT				

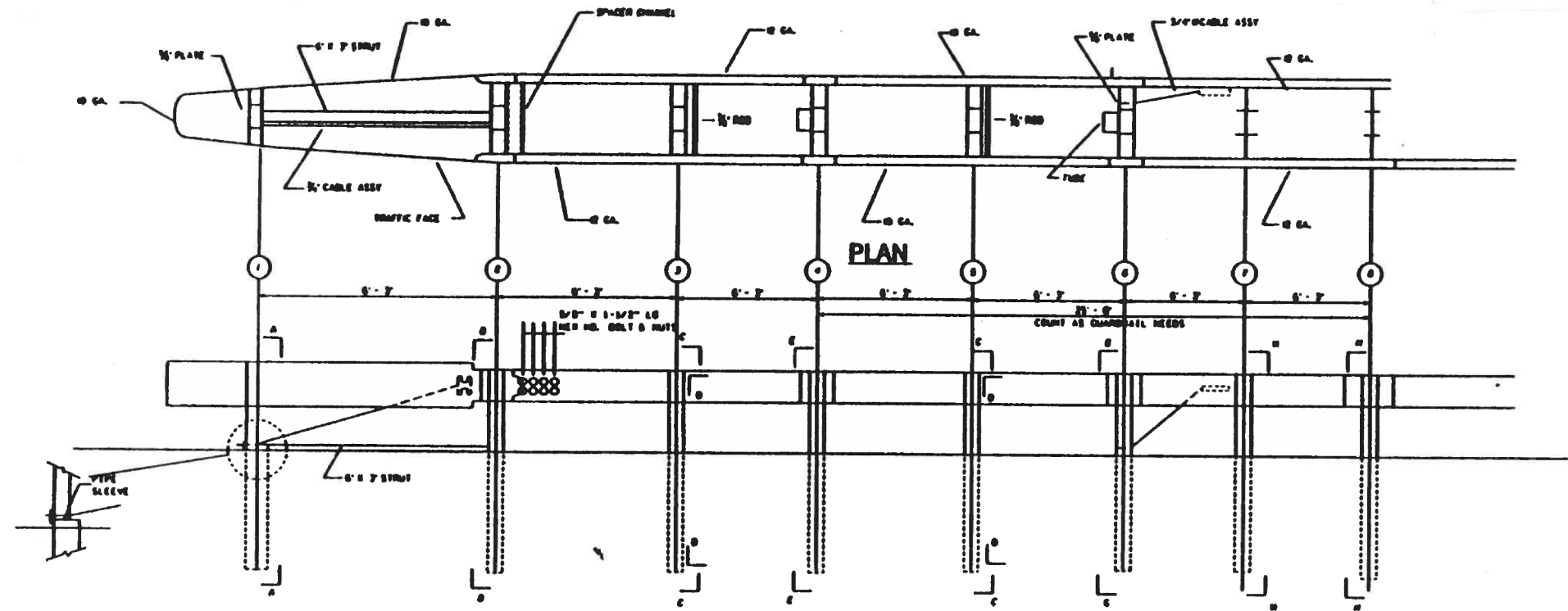

**DETAIL INCLUDED
FOR REPAIR ONLY**

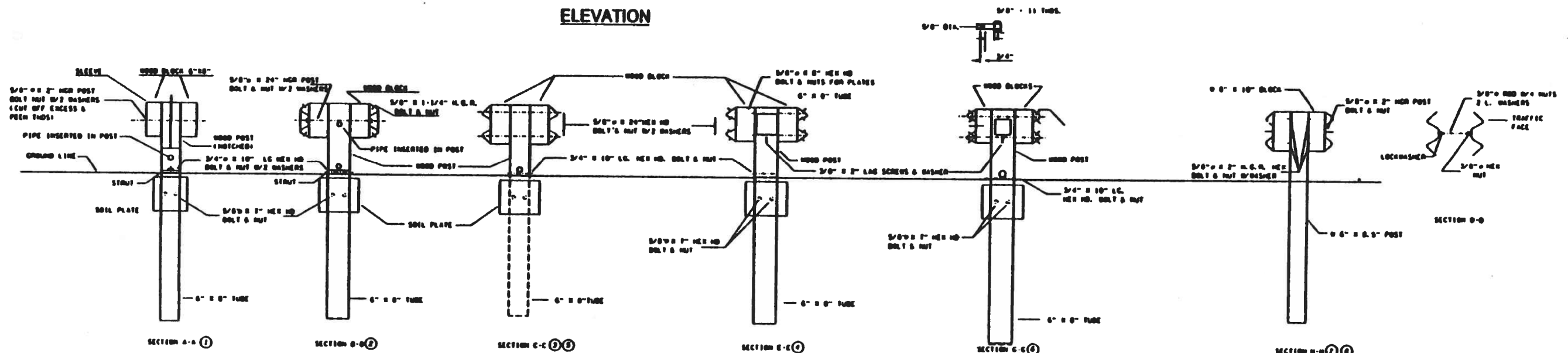

FILE NAME =	USER NAME = letemove	DESIGNED -	REVISED -
pw\planroom.dot.illinois.gov\PIWIDOT\Documents\IDOT Offices\District 4\Projects\D4.68\Drawings\CADD\Drawings\D4xxxx-CADD.dgn		REVISION	REVISION
Default	PLOT SCALE = 48.0000' / in.	CHECKED -	REVISED -
	PLOT DATE = 12/8/2020	DATE -	REVISED -

**STATE OF ILLINOIS
DEPARTMENT OF TRANSPORTATION**

PROPOSED C.A.T. SYSTEM

SCALE: SHEET 1 OF 1 SHEETS STA. TO STA.

F.A. RTE.	SECTION	COUNTY	TOTAL SHEETS	SHEET NO.
VAR	D4 GUARDRAIL REPAIRS 2021-MCHD	VARIOUS	27	9
			CONTRACT NO. 68F96	
ILLINOIS FED. AID PROJECT				

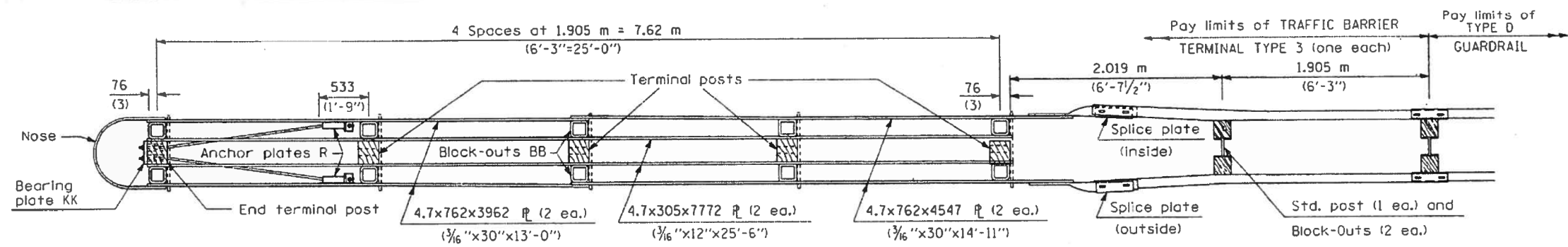

PLAN - TRAFFIC BARRIER TERMINAL TYPE 3

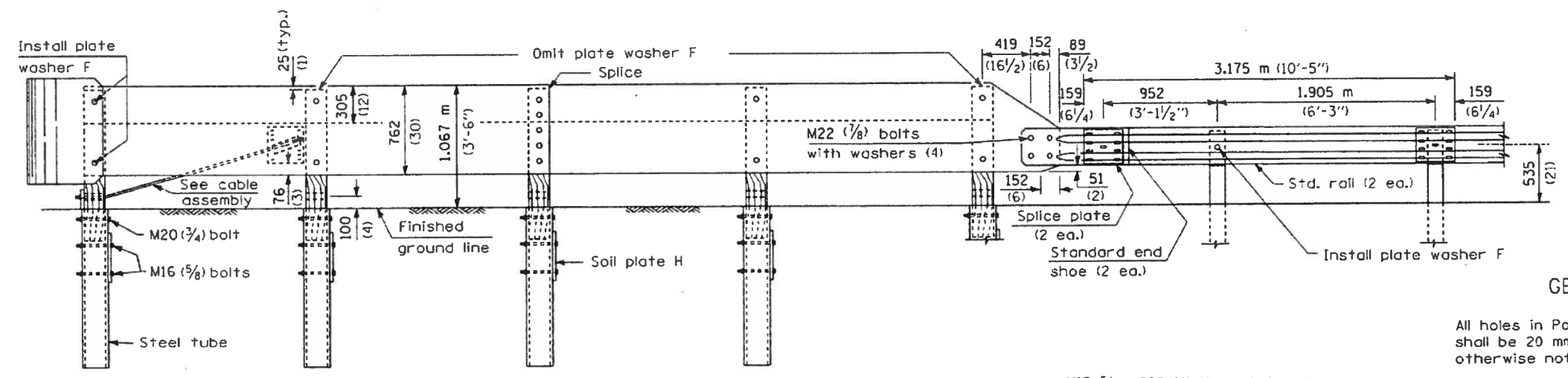

ELEVATION

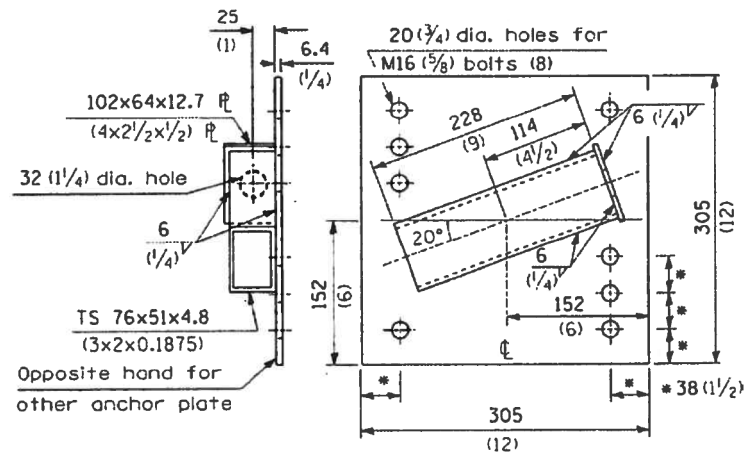

ANCHOR PLATE R
(1 ea. lt. hd. & 1 ea. rt. hd.)

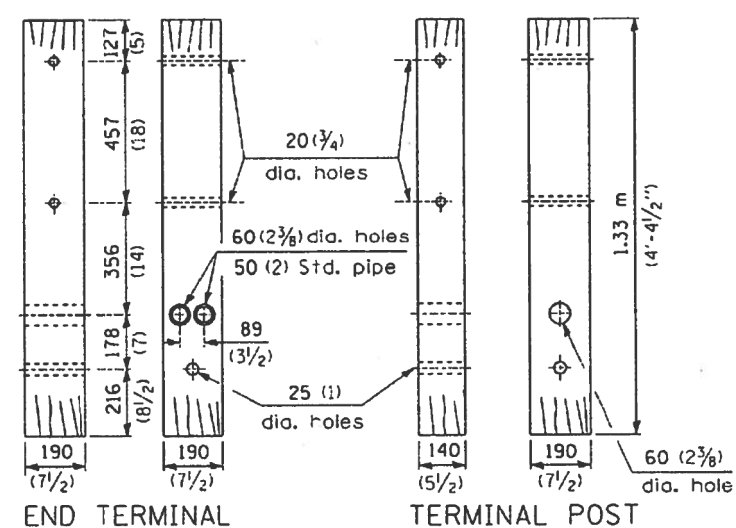

END TERMINAL POST (1 ea.)
TERMINAL POST (4 ea. Type 3) (5 ea. Type 3A)

M16 (5/8) x 280 (11) threaded rod with nuts and washers (10 ea. Type 3) (12 ea. Type 3A)

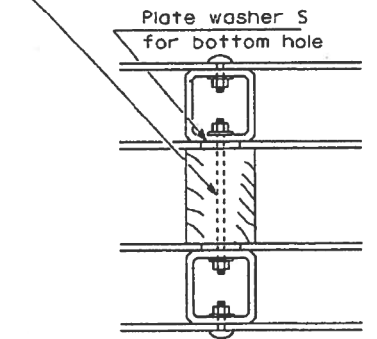

TYPICAL BLOCK-OUT/POST ATTACHMENT

GENERAL NOTES

- All holes in Posts, Block-Outs and Plates shall be 20 mm (3/4") diameter unless otherwise noted.
- See Standard 630001 for details of guardrail elements not shown.
- Unless otherwise shown all bolts and nuts shall be Standard Post and Splice Bolts and Nuts (See Standard 630001).
- Block-Out AA shall be used at all locations unless otherwise noted.

DETAIL INCLUDED FOR REPAIR ONLY

All dimensions are in millimeters (inches) unless otherwise shown.

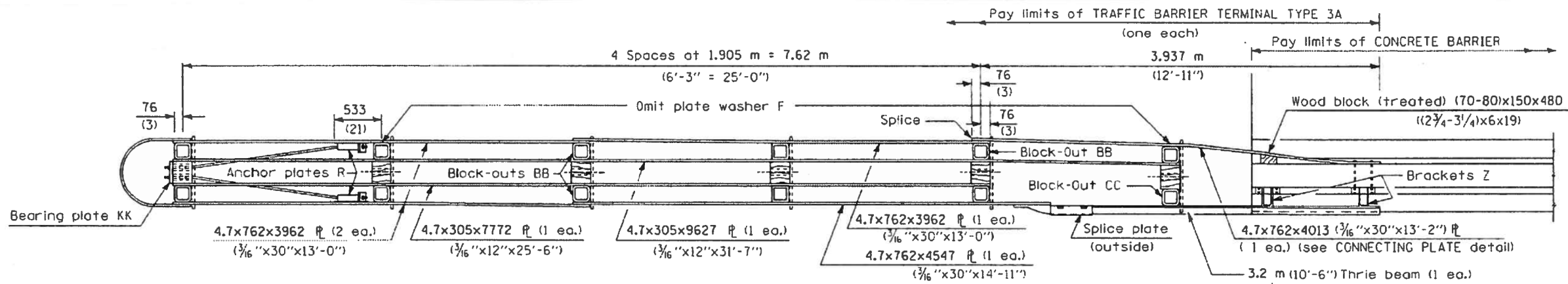

PLAN - TRAFFIC BARRIER TERMINAL TYPE 3A

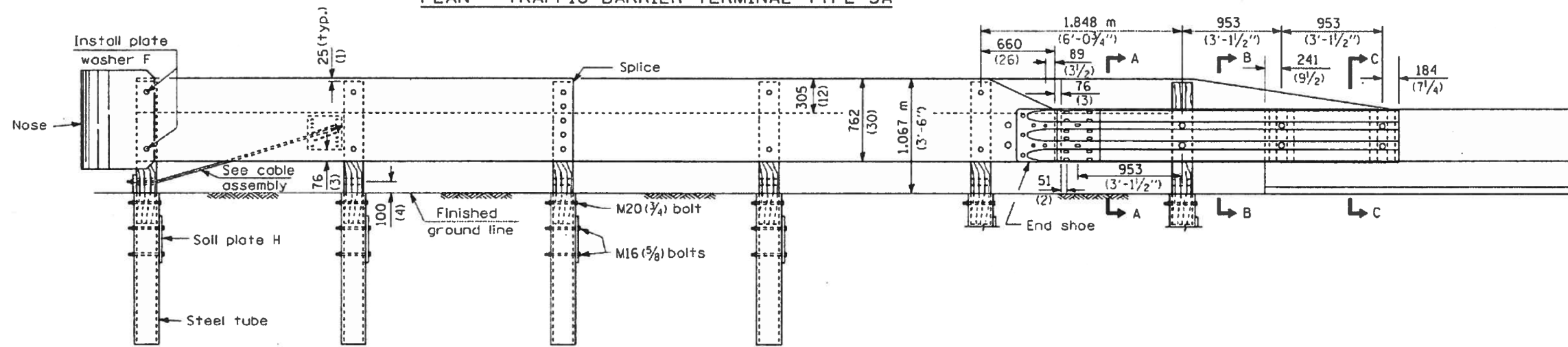

ELEVATION

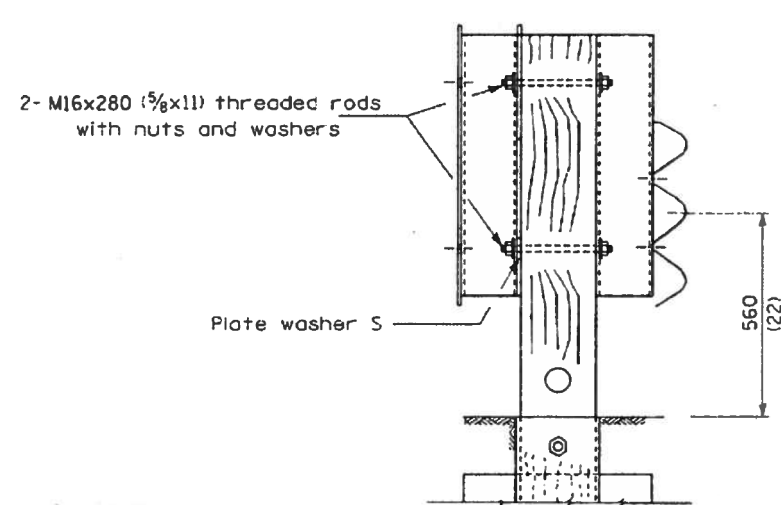

SECTION A-A

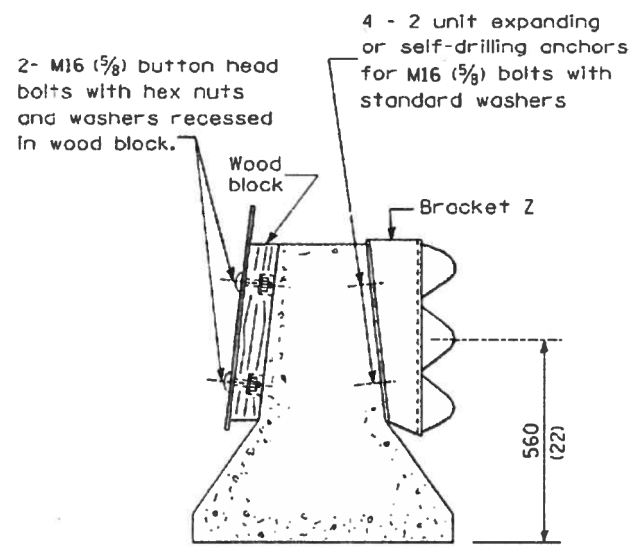

SECTION B-B

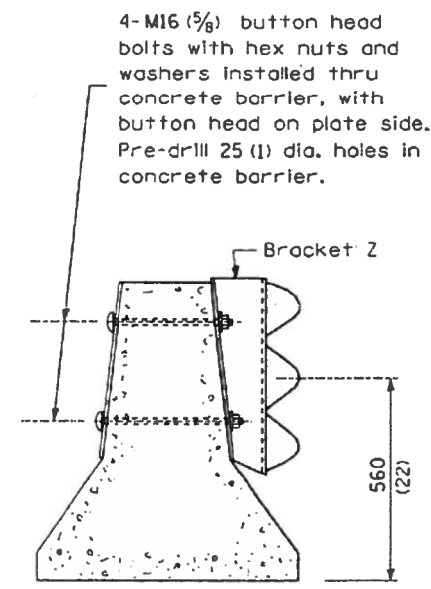

SECTION C-C

**DETAIL INCLUDED
FOR REPAIR ONLY**

All dimensions are in millimeters (inches) unless otherwise shown.

FILE NAME =	USER NAME = letemove	DESIGNED -	REVISED -	STATE OF ILLINOIS DEPARTMENT OF TRANSPORTATION	EXISTING TRAFFIC BARRIER TERMINAL TYPE 3 & TYPE 3A	F.A. RTE.	SECTION	COUNTY	TOTAL SHEETS	SHEET NO.	
pw\planroom.dot.illinois.gov\PIWIDOT\Documents\IDOT Offices\District 4\Projects\D4.68\Drawings\CADD\Drawings\D4xxxx-CADD.dgn	PLOT SCALE = 40.0000' / in.	CHECKED -	REVISED -			VAR	D4 GUARDRAIL REPAIRS 2021-MCHD	VARIOUS	27	11	
Default	PLOT DATE = 12/8/2020	DATE -	REVISED -			CONTRACT NO. 68F96			ILLINOIS FED. AID PROJECT		
						SCALE:	SHEET 2	OF 3 SHEETS	STA.	TO STA.	

TYPE 3A ONLY

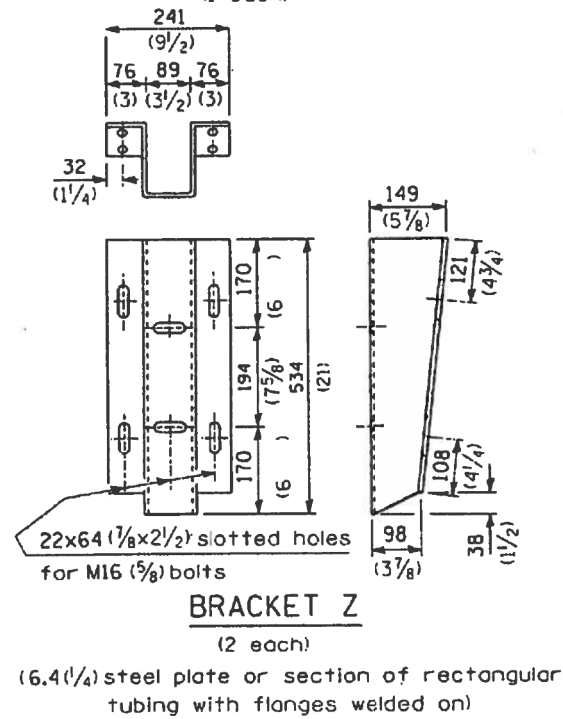
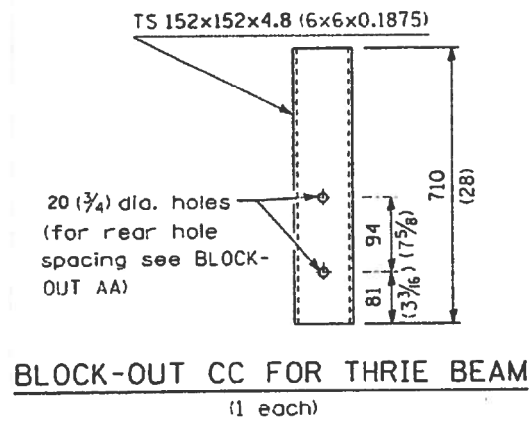
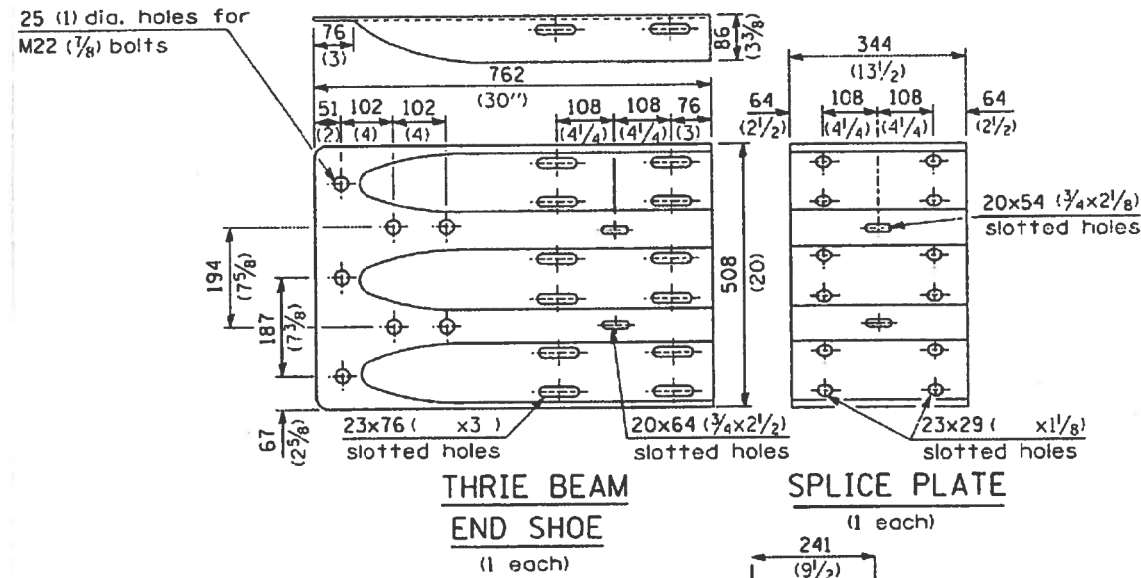
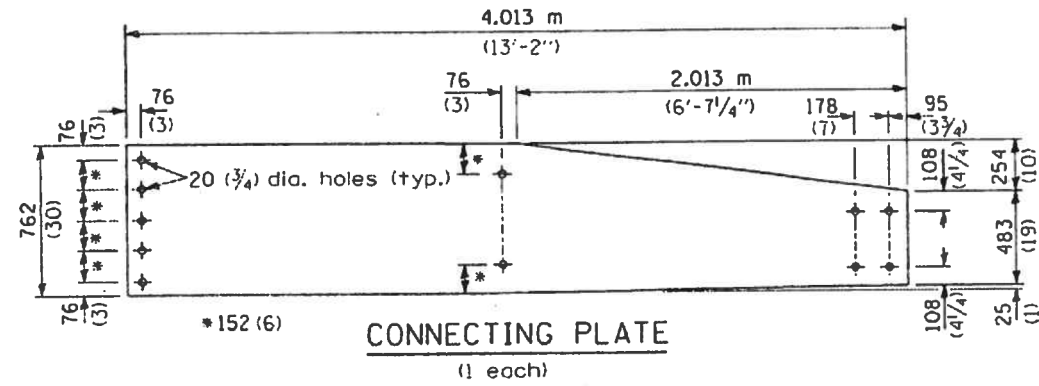

TYPE 3 & 3A

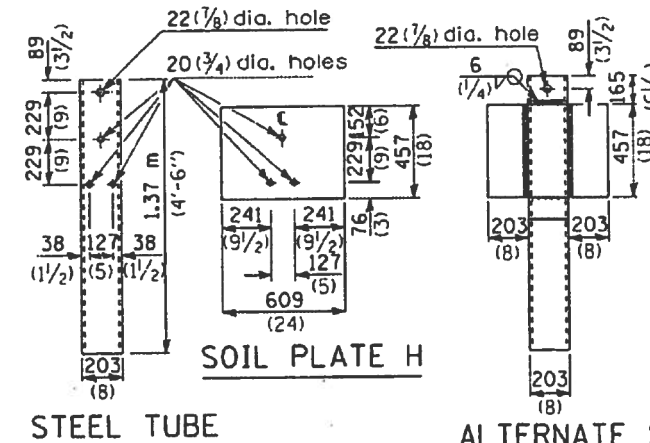
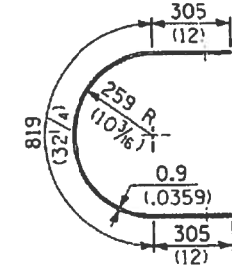
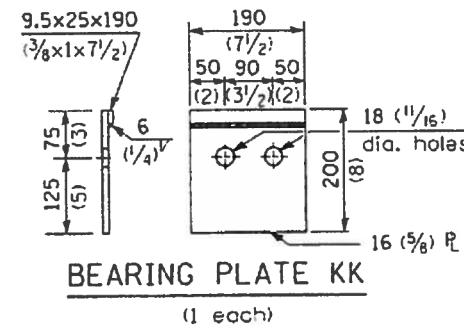

TS 203x203x4.8 (8x8x0.1875)
(end terminal post) (1 ea.)

TS 203x152x4.8 (8x6x0.1875)
(terminal post) (4 ea. Type 3)
(5 ea. Type 3A)

ALTERNATE SOIL PLATE CONNECTION

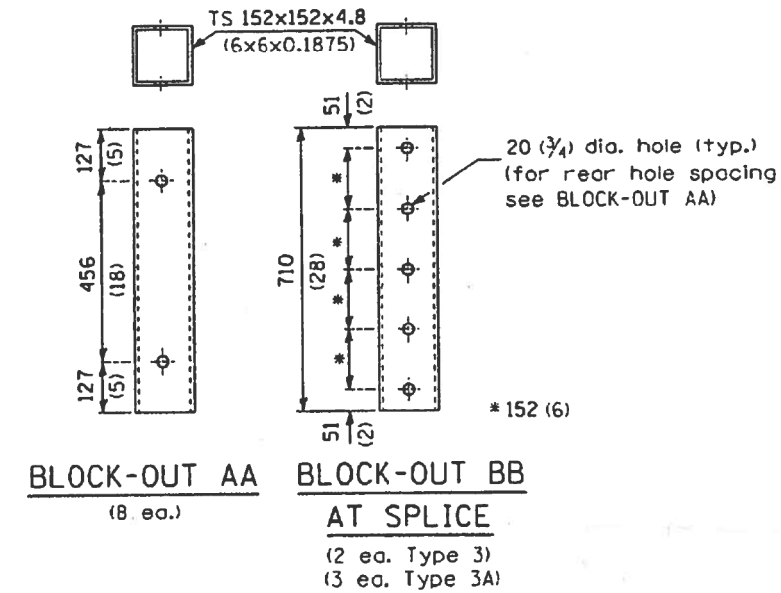
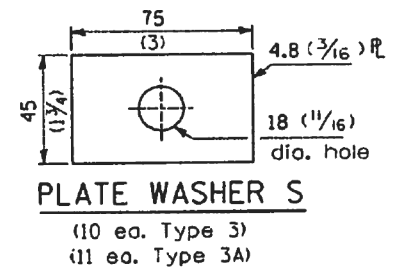

DETAIL INCLUDED FOR REPAIR ONLY

All dimensions are in millimeters (inches) unless otherwise shown.

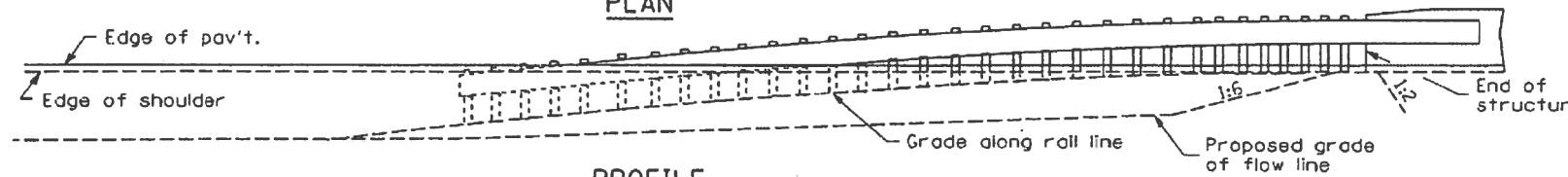
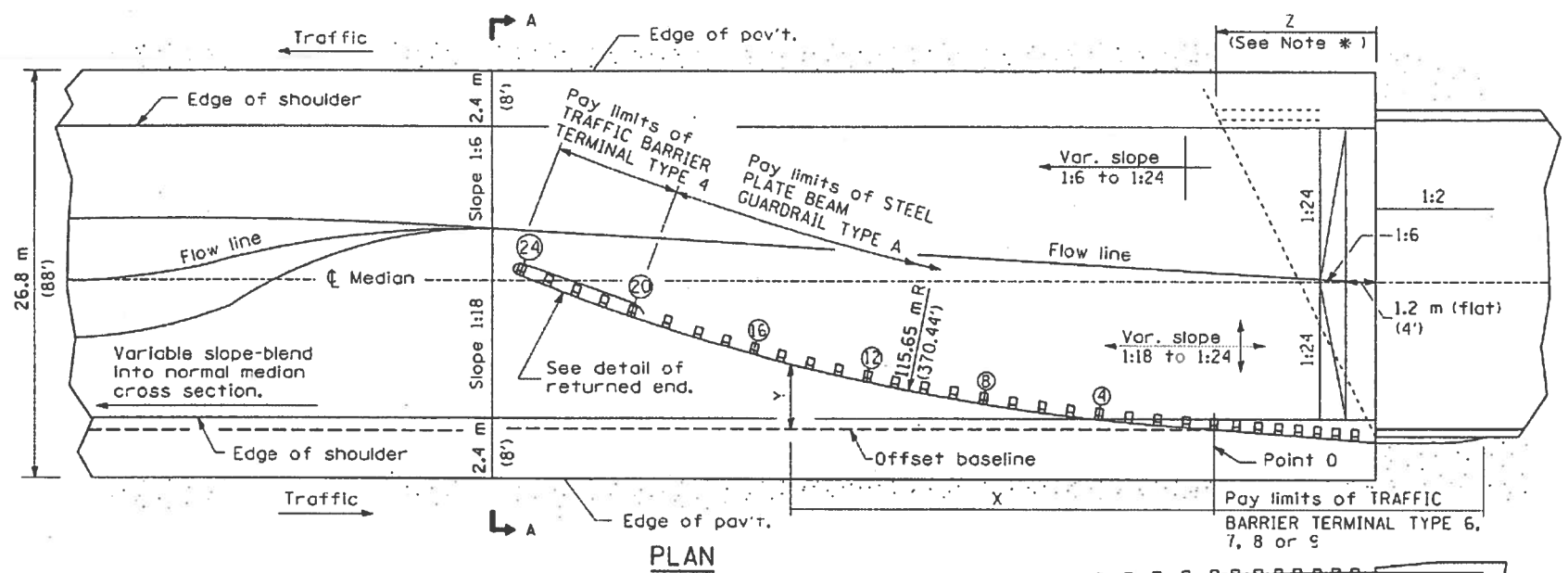

PROFILE
ASSEMBLY FOR 26.8 m (88 ft.) MEDIAN

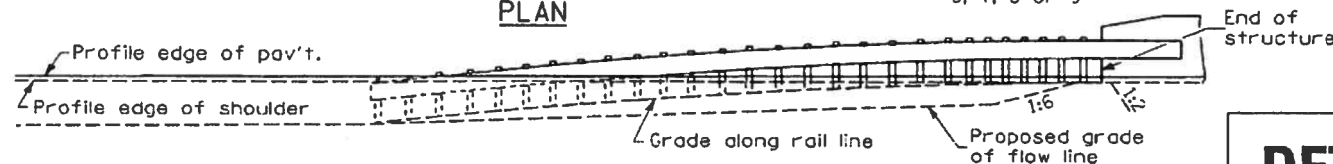
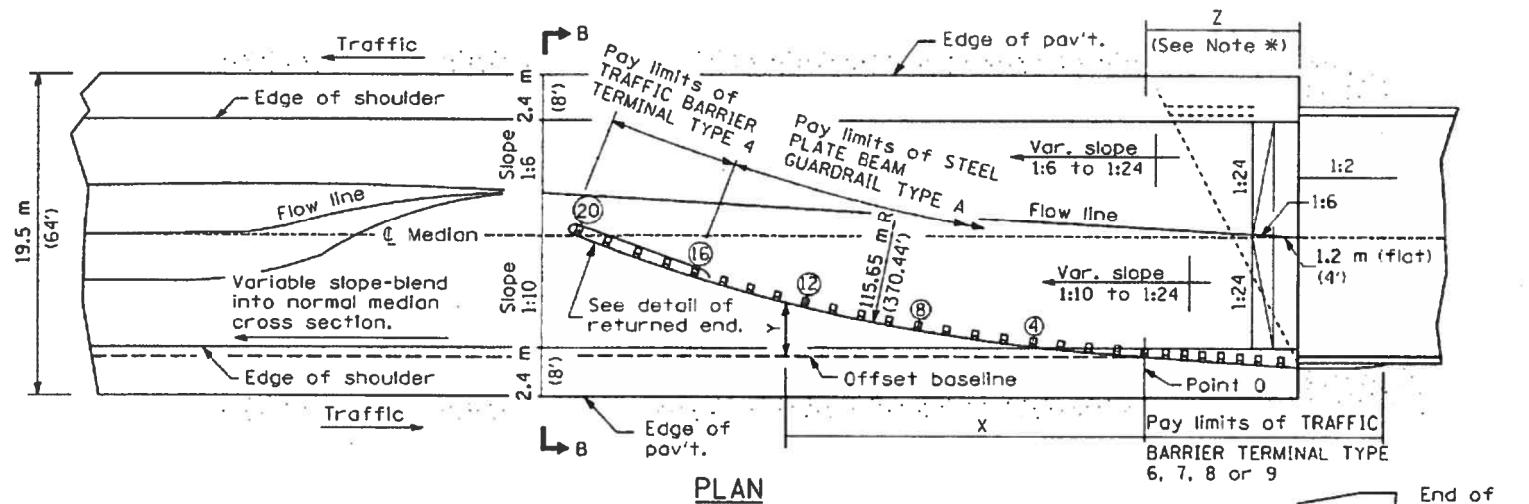

PROFILE
ASSEMBLY FOR 19.5 m (64 ft.) MEDIAN

OFFSETS TO FACE OF RAIL

POINT	DISTANCE X m (ft.)	OFFSET Y m (ft.)
0	0 (0)	0 (0)
④	7.60 (24.93)	0.56 (1.83)
⑧	15.14 (49.68)	1.60 (5.28)
⑫	22.60 (74.16)	3.16 (10.37)
⑮	29.94 (98.23)	5.20 (17.05)
⑳	37.13 (121.83)	7.71 (25.3)
㉑	44.14 (144.83)	10.70 (35.09)

Offsets (Y) are measured between the face of rail and the offset baseline, which is parallel to the pavement edge and passes through point 0.

The location of point 0 will vary, being dependent on structure details and the type of traffic barrier terminal utilized.

GENERAL NOTES

See Standard 630001 for details of guard-rail not shown.

*For dual structures skewed right forward, the nose of the Type 4 terminal shall be positioned longitudinally away from the structure for a distance equal to dimension Z. Appropriate adjustments to the length of the Type A guardrail and its offsets (Y) shall be calculated and used. All additional lengths of guardrail shall be in increments of 3.87 m (12'-6").

For dual structures that are 90°, or skewed left forward, the length of guardrail is appropriate.

The bearing plate K shall be held in position by (2) two eight penny nails driven into the post and bent over the top of the plate.

All slopes are expressed as units of vertical displacement to units of horizontal displacement (V:H).

All dimensions are in millimeters (inches) unless otherwise shown.

All dimensions are in millimeters (inches) unless otherwise shown.

**DETAIL INCLUDED
FOR REPAIR ONLY**

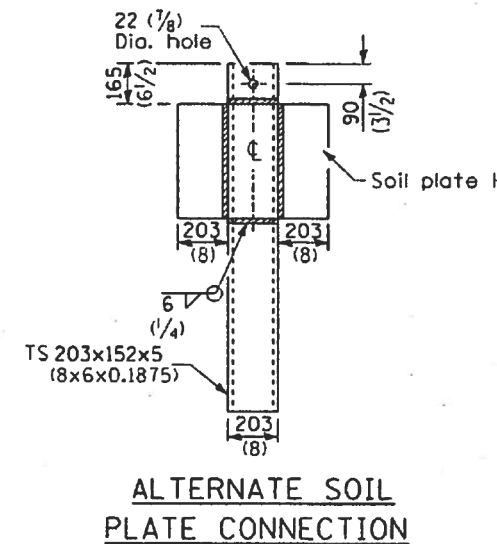
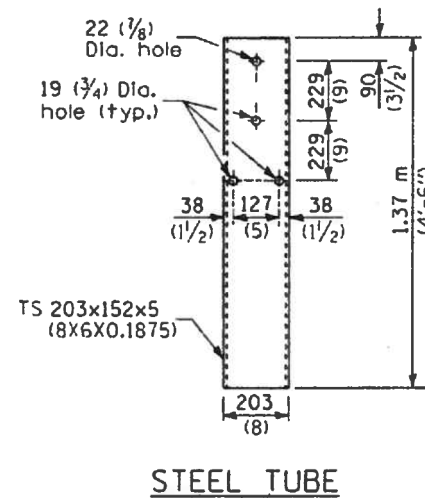
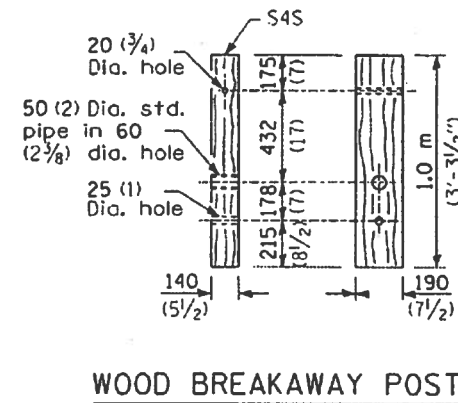
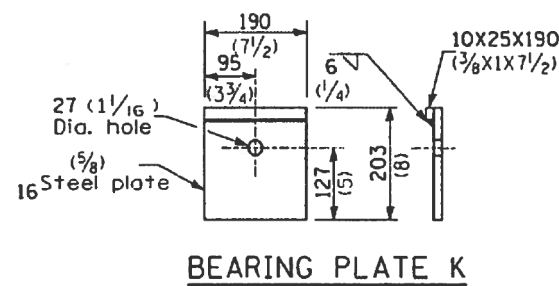
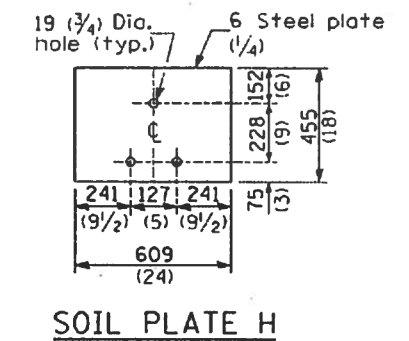
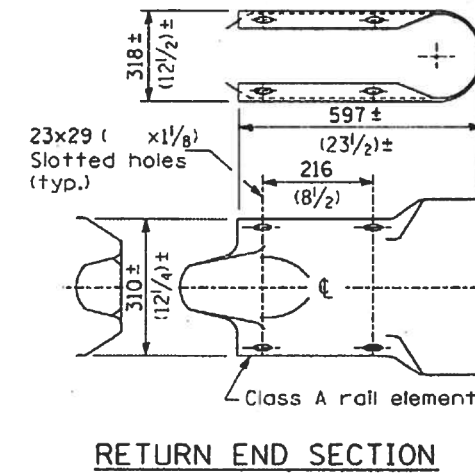
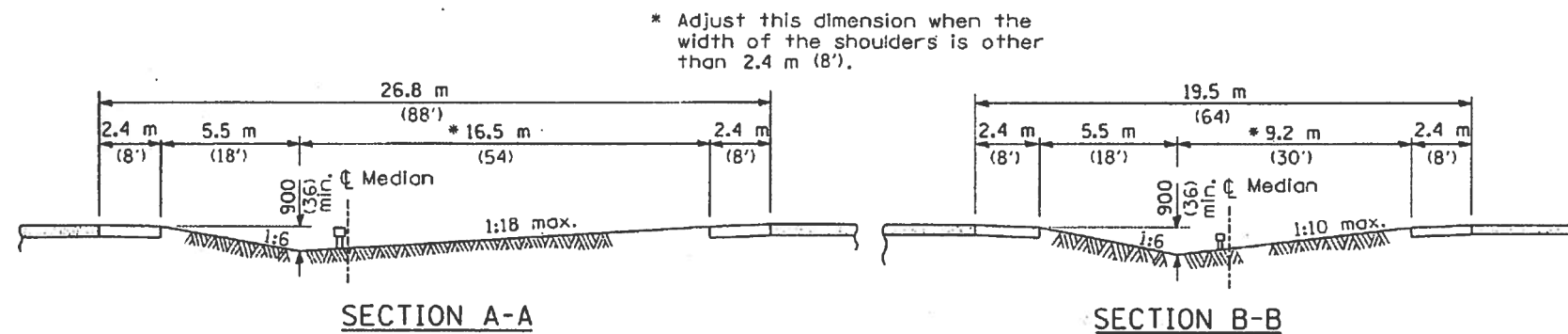
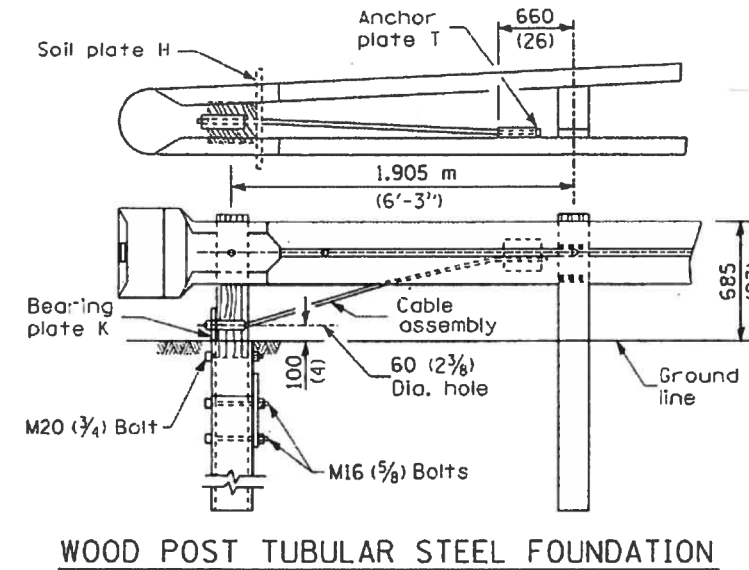
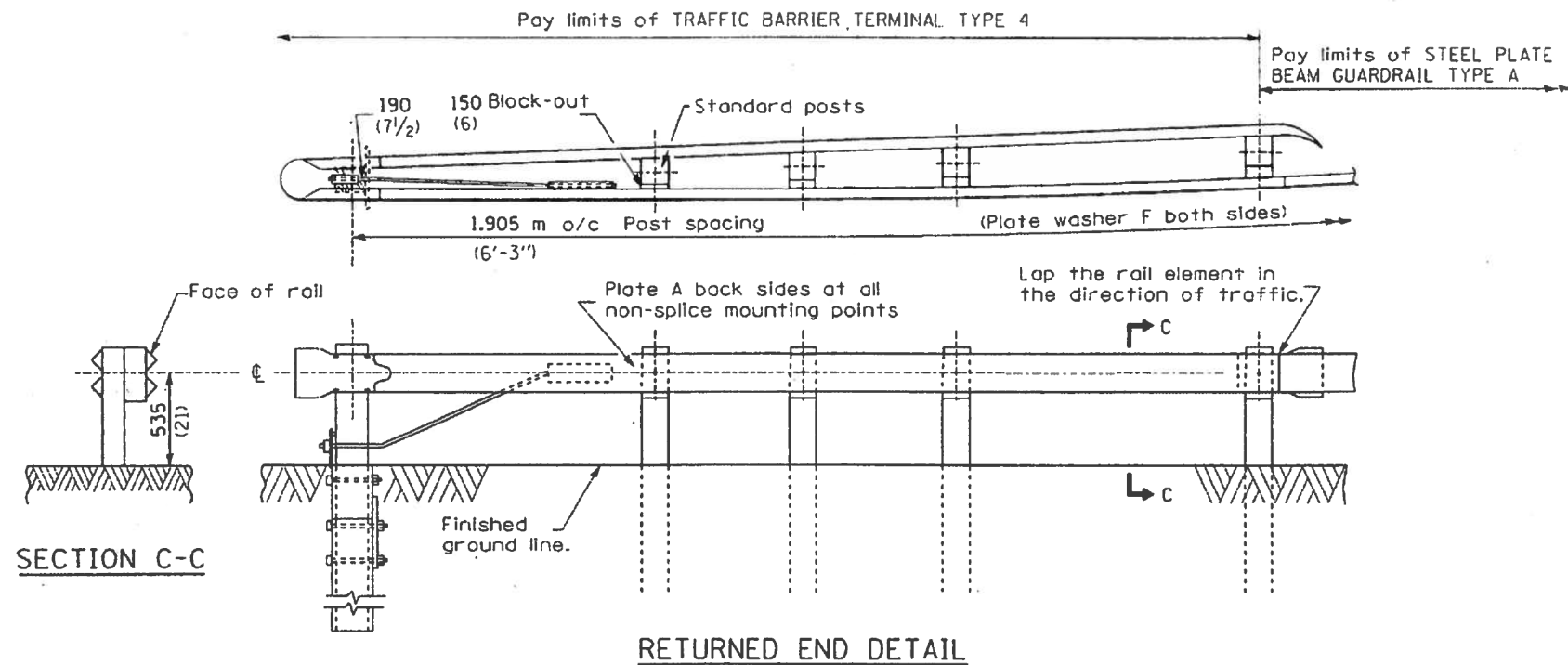

DETAIL INCLUDED FOR REPAIR ONLY

All dimensions are in millimeters (inches) unless otherwise shown.

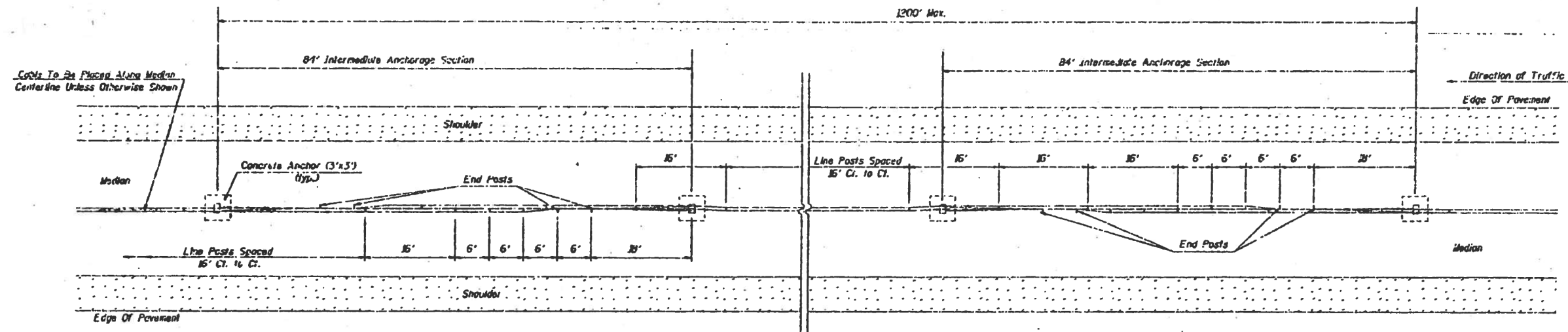

TYPICAL CABLE MEDIAN BARRIER ANCHORAGE LAYOUT
 PLAN VIEW
 Not to Scale

GENERAL NOTE

DELINEATORS: Two reflectors, placed back to back, shall be required for each delineator post.

NOTE: This work shall be done in accordance with Section 635 and no additional compensation will be allowed for two single reflector units placed back to back.

The delineator shall be installed adjacent to a cable road guard post at 80 foot centers.

Notes:
 1. All posts are line posts unless otherwise specified.
 2. See detail sheets for Post, Concrete Anchor and Assembly Parts specifications.

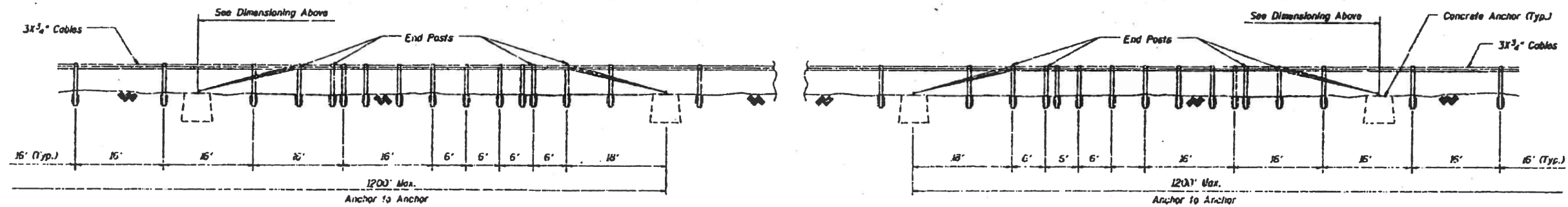

TYPICAL CABLE MEDIAN BARRIER ANCHORAGE LAYOUT
 ELEVATION VIEW
 Not to Scale

**DETAIL INCLUDED
 FOR REPAIR ONLY**

FILE NAME =	USER NAME = letemove	DESIGNED -	REVISED -	STATE OF ILLINOIS DEPARTMENT OF TRANSPORTATION	EXISTING CABLE MEDIAN BARRIER (CABLE ROAD GUARD)	F.A. RTE.	SECTION	COUNTY	TOTAL SHEETS	SHEET NO.
pw\planroom.dot.illinois.gov\PWIDOT\Documents\IDOT Offices\District 4\Projects\D4.68\Drawings\CADD\Drawings\D4xxxx-CADD.dgn		DRWN -	REVISED -			VAR	D4 GUARDRAIL REPAIRS 2021-MCHD	VARIOUS	27	15
PLOT SCALE = 48.0000' / in.		CHECKED -	REVISED -			CONTRACT NO. 68F96				
Default		DATE -	REVISED -			ILLINOIS FED. AID PROJECT				
	PLOT DATE = 12/8/2020			SCALE:	SHEET 1 OF 3 SHEETS	STA.	TO STA.			

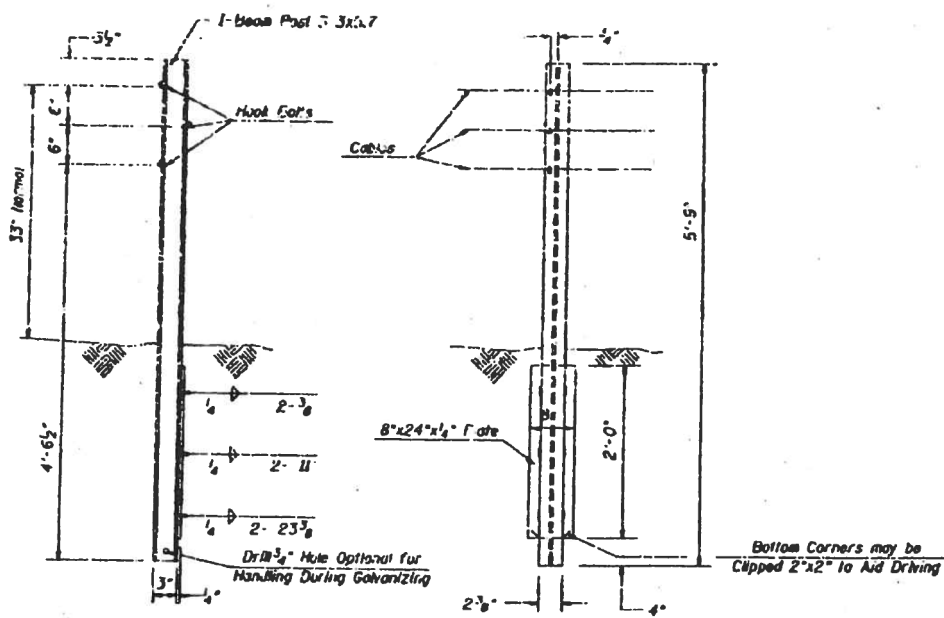

LINE POST DETAIL

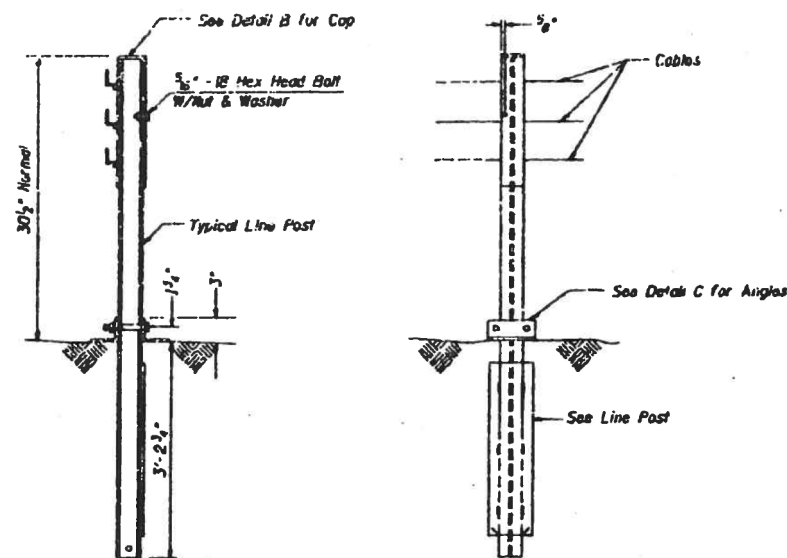

END POST DETAIL

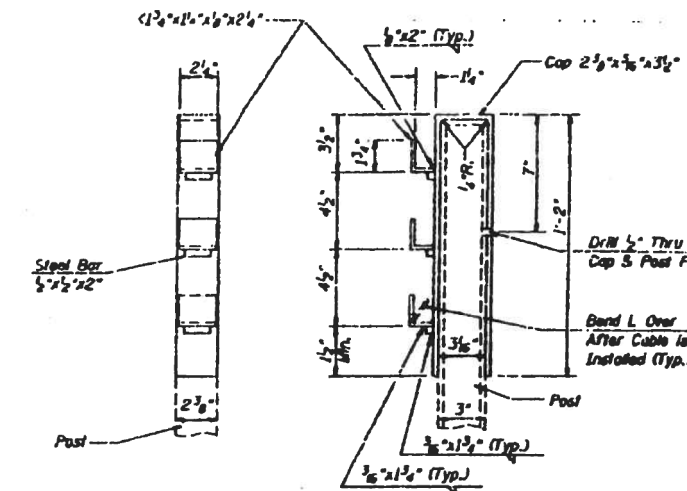

DETAIL B

NOTES

- At all locations where the cable is connected to a cable socket with a wedge type connection, one wire of the wire rope shall be crimped over the base of the wedge to hold it firmly in place.
- Compensating devices shall have spring constants of 450 Pounds Per Inch, plus or minus 50 Pounds Per Inch, and permit a travel of 5 inches, plus or minus 1 inch.
- Socket baskets shall be designed for use with the wedge detailed in these Standards.
- Alternate hardware designs will be considered for approval provided their connection details, for the purpose of maintenance substitutions, are compatible with the details of these standards and their operating characteristics are similar to those of the hardware shown.
- Threads of externally threaded parts shall be UNC, Class 2A tolerance (A.N.S.I. B1.1). Internally threaded parts shall meet the dimensional requirements of ASTM A 563.
- All fittings (including splices) shall be so designed to use the wedge shown in the wedge detail and shall be of such section as to develop the full strength of the 3/4" round cable (25,000 Lbs.).
- For arrangement of spring cable end assemblies (compensating devices) and turnbuckle cable end assemblies, the following criteria shall apply.
 Length of Cable Runs
 To 1000' - Use compensating cable and assembly on one end, and turnbuckle cable and assembly on the other end of each individual cable.
 Over 1000' to 2000' - Use compensating cable end assembly on each end of each individual cable.
- All assembly parts and posts are to be galvanized and no punching, cutting or welding will be permitted after galvanizing.
- Dimensional tolerances not shown or implied are intended to be those consistent with the proper functioning of the part, including its appearance, and accepted manufacturing practices.
- Prior to final acceptance by the State the following procedures shall be used to tighten the turnbuckles, depending on the temperature at the time of adjustment in accordance with the following table.

Temperature	120°	99°	79°	59°	39°	19°	1°
	10	10	10	10	10	10	10
	100°	80°	60°	40°	20°	1°	20°

 Spring Compression from unstressed position in each spring

	1"	1 1/2"	2"	2 1/2"	3"	3 1/2"	4"
--	----	--------	----	--------	----	--------	----

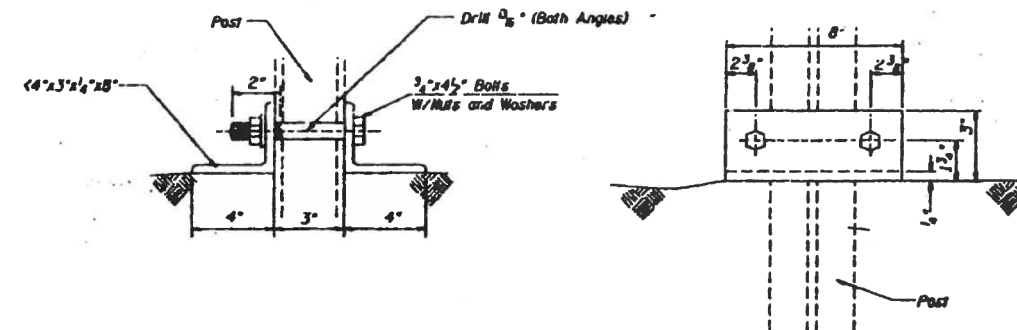

DETAIL C

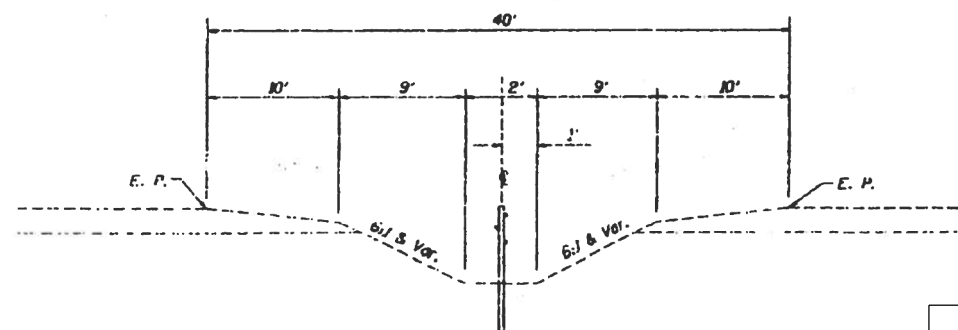

CABLE MEDIAN BARRIER TYPICAL SECTION

DETAIL INCLUDED FOR REPAIR ONLY

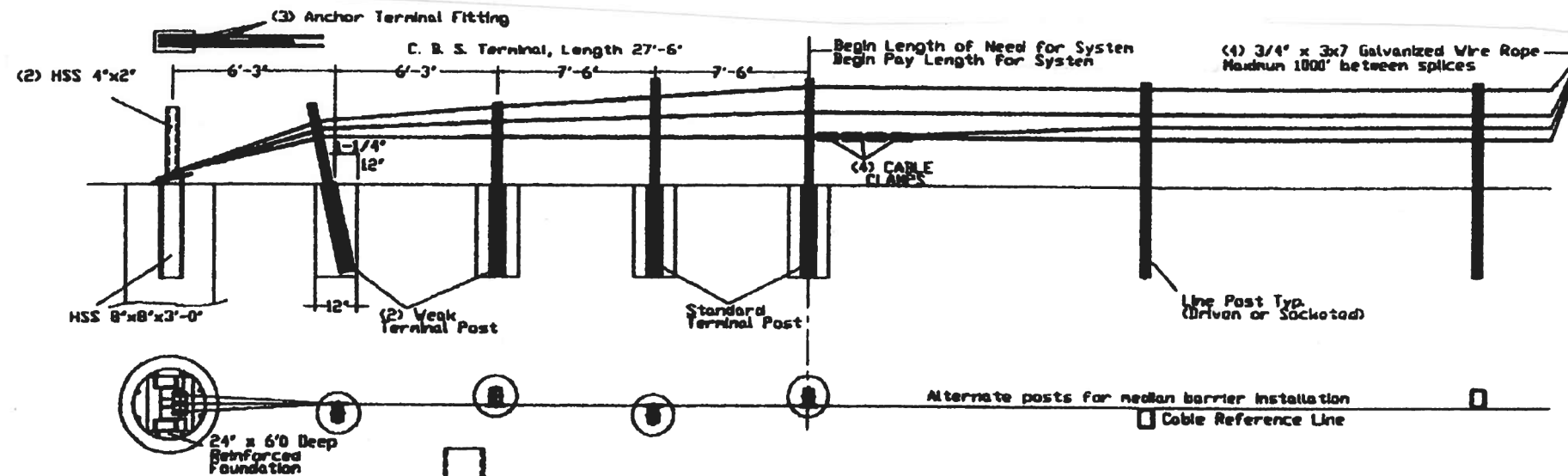

BASE-PLATED POST
 For Use On Concrete
 5/8" Mechanical Anchor
 Min. Pullout Strength 10,000 lbs.

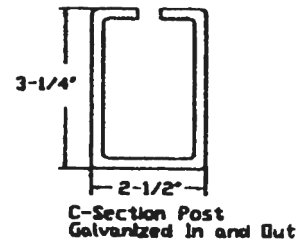
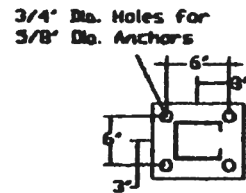

GENERAL NOTES

- For additional information contact Gibraltar, Inc. at 1-800-493-8937, or see the manufacturer's product manual.
- All concrete shall be minimum 2500 PSI.
- Alternate Post for bi-directional traffic flow. If installed for traffic in one direction install cables on traffic side of posts.
- The Cable Barrier System shall be installed on median shoulders or on depressed medians with slopes of 6:1 or flatter.
- The Cable Barrier System is accepted by the FHWA Test Level - 4
- See the MUTCD for proper 'Barrier' delineation
- Rock Clause: Where solid rock is encountered
 - For socketed post, continue digging 12" diameter, 15' deep into rock or the required plan depth, whichever comes first.
 - For driven post, core drill a 4" diameter hole 18" deep into rock or the required plan depth, whichever comes first.
 - For Anchor post, continue digging 24" diameter, 30' deep into rock or the required plan depth, whichever comes first.
- Every component to be galvanized.

Cable Tension	
-10F	8000
0	7600
10	7200
20	6800
30	6400
40	6000
50	5600
60	5200
70	4800
80	4400
90	4000
100	3600
110	3200

Allowable Deviation from Chart +/- 200 lbs/force

Deflection	Post Spacing
9'3"	30.FT
9'	28.FT
8'	20.FT
7'	12.FT
6'8"	10.FT

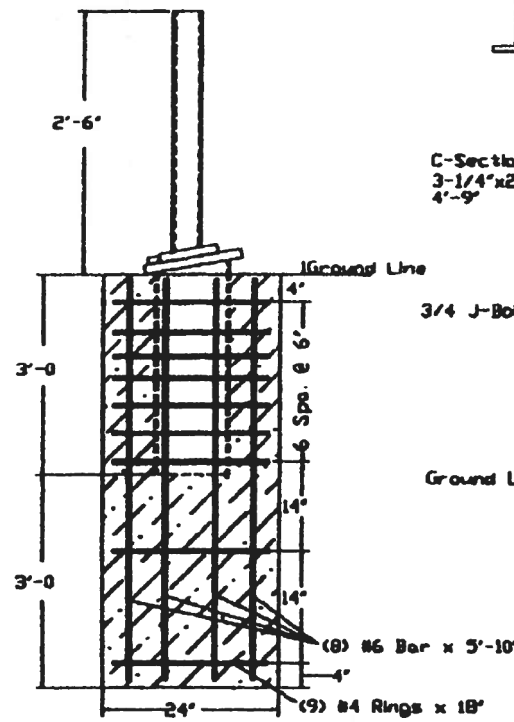

Cable Release Anchor Post

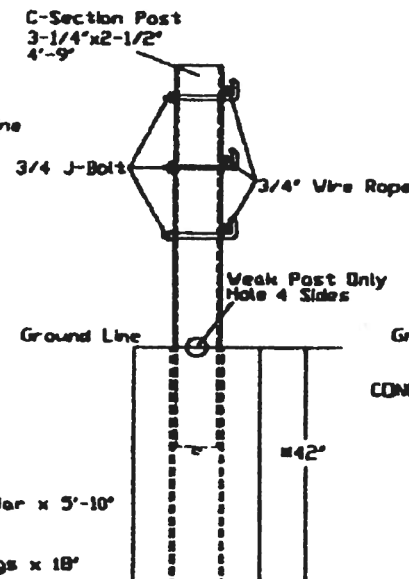

Terminal Post

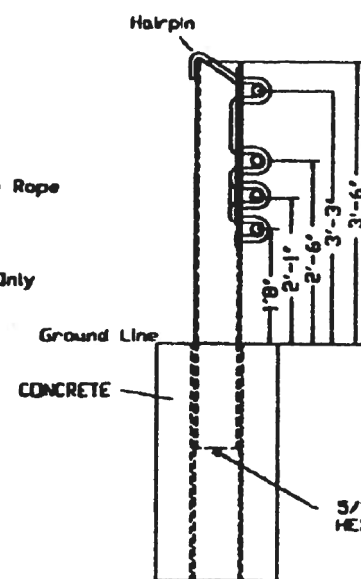

Line Post (Socketed)

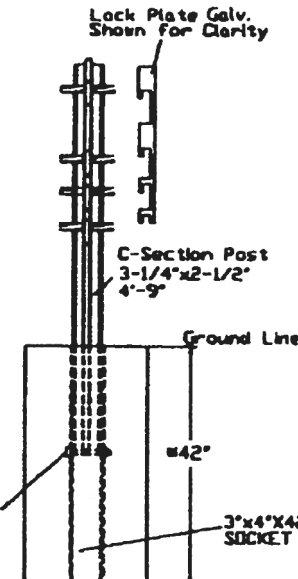

Socketed Line Post (Driven)

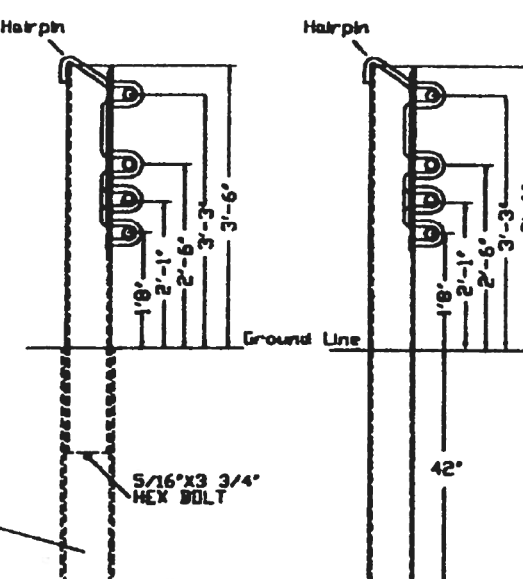

Line Post (Driven)

#30" DIA Deep concrete foundation with Min. 18" wide Max Strip
 #42"x12" DIA Deep w/o Max Strip

DETAIL INCLUDED FOR REPAIR ONLY

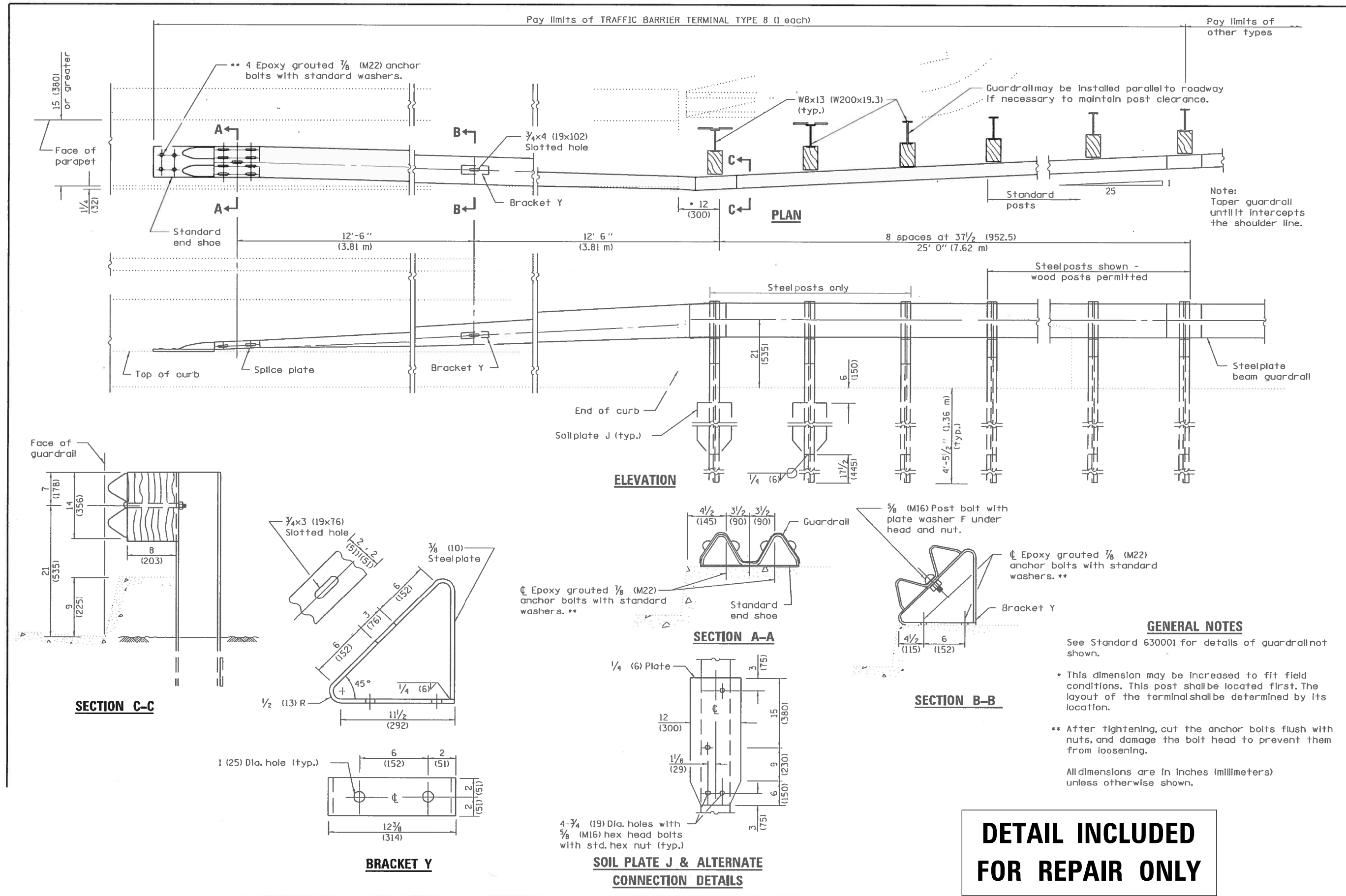

FILE NAME =	USER NAME = letemove	DESIGNED -	REVISED -
p:\planroom.dot.illinois.gov\PIWIDOT\Documents\IDOT Offices\District 4\Projects\D4.68\Drawings\CADD\Drawings\D4xxxx-CADD.dgn		REVISIONS	REVISIONS
		CHECKED -	REVISED -
Default	PLOT DATE = 12/8/2020	DATE -	REVISED -

STATE OF ILLINOIS
DEPARTMENT OF TRANSPORTATION

EXISTING TRAFFIC BARRIER TERMINAL TYPE 8
(STANDARD 631036)

SCALE: SHEET 1 OF 1 SHEETS STA. TO STA.

F.A. RTE.	SECTION	COUNTY	TOTAL SHEETS	SHEET NO.
VAR	D4 GUARDRAIL REPAIRS 2021-MCHD	VARIOUS	27	19
			CONTRACT NO. 68F96	
ILLINOIS FED. AID PROJECT				

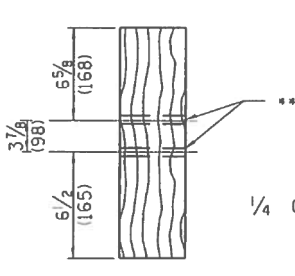
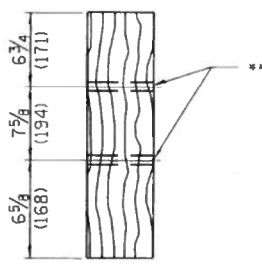
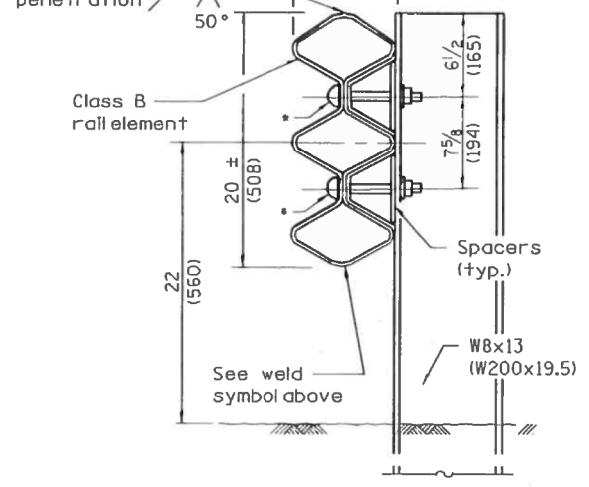
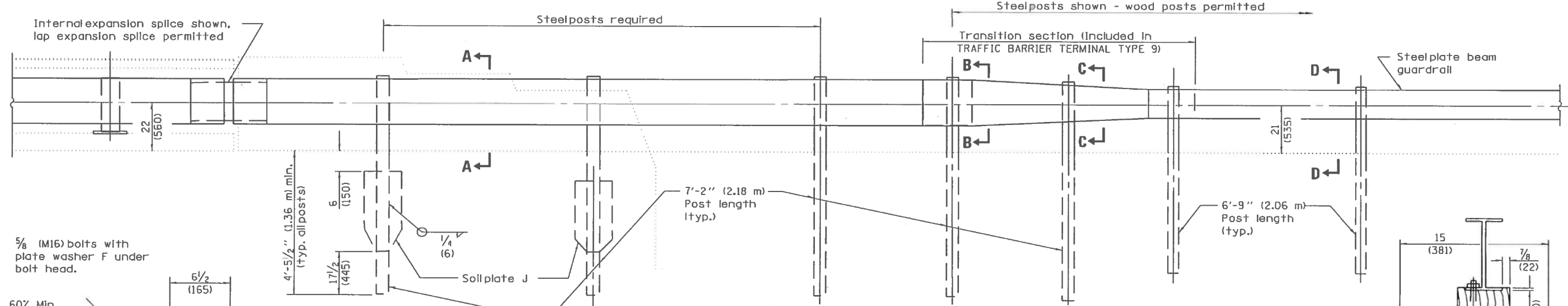
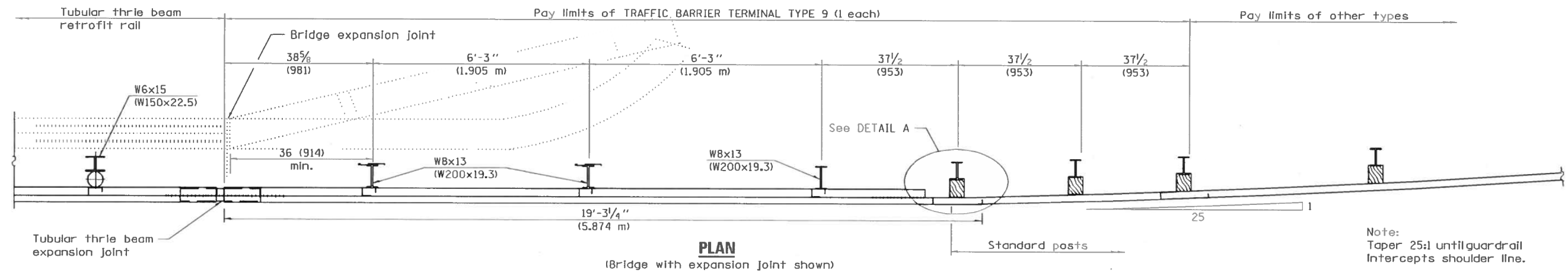

DETAILS of BLOCK-OUTS
•• ϕ 3/4 (19) Dia. hole

4-3/4 (19) Dia. holes with 5/8 (M16) hex head bolts with std. hex nut (typ.)

SOIL PLATE J & ALTERNATE CONNECTION DETAILS

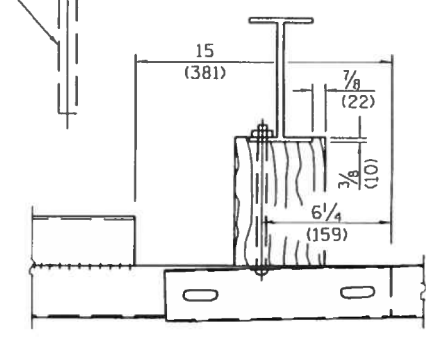
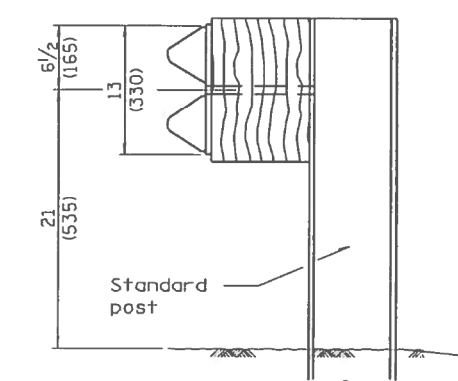

GENERAL NOTES

See Standards 509001 and 630001 for details of guardrailelements not shown.

The Type 9 terminal shall be installed after the posts for the bridge retrofit rail have been located as shown on Standard 509001.

All dimensions are in inches (millimeters) unless otherwise shown.

DETAIL INCLUDED FOR REPAIR ONLY

FILE NAME =	USER NAME = letemove	DESIGNED -	REVISED -	STATE OF ILLINOIS DEPARTMENT OF TRANSPORTATION	EXISTING TRAFFIC BARRIER TERMINAL TYPE 9 (STANDARD 631041)	F.A. RTE.	SECTION	COUNTY	TOTAL SHEETS	SHEET NO.
pw:\planroom.dot.illinois.gov\PIWIDOT\Documents\IDOT Offices\District 4\Projects\D4.68\Drawings\CADD\Drawings\D4xxxx-CADD.dgn		CHECKED -	REVISED -			VAR	D4 GUARDRAIL REPAIRS 2021-MCHD	VARIOUS	27	20
PLOT SCALE = 40.0000' / in.		DATE -	REVISED -			CONTRACT NO. 68F96				
Default						ILLINOIS FED. AID PROJECT				

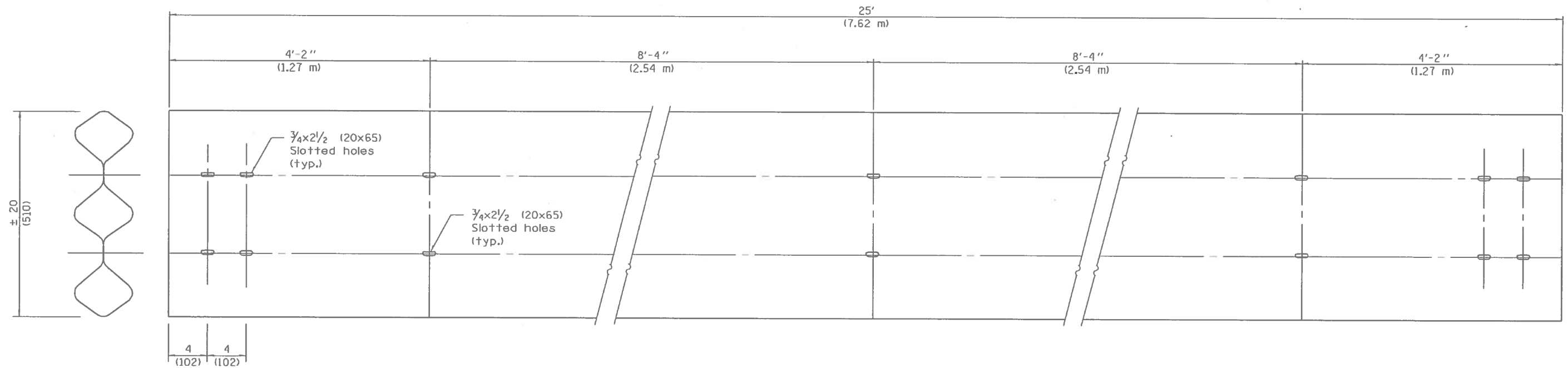

TUBULAR THRIE BEAM FOR INTERNAL SPLICE JOINT

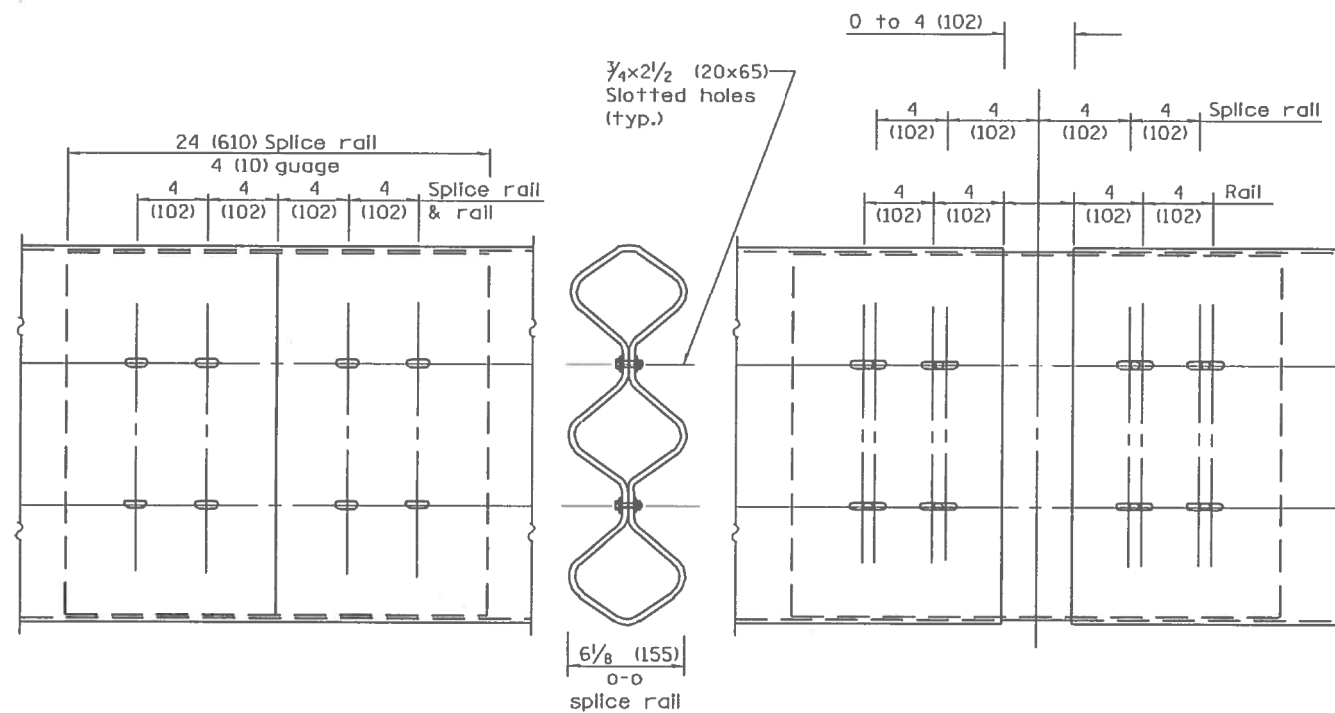

INTERNAL SPLICE JOINT

INTERNAL EXPANSION SPLICE JOINT

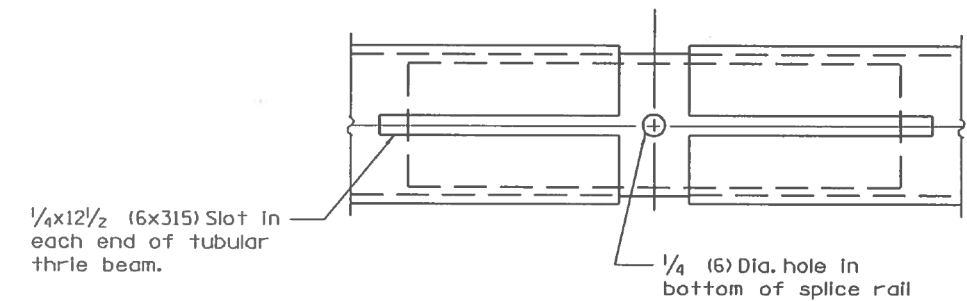

BOTTOM VIEW OF INTERNAL EXPANSION SPLICE JOINT

DETAIL INCLUDED FOR REPAIR ONLY

GENERAL NOTES

Plate Washers B are to be placed under both heads and nuts of splicing bolts for internal splice and internal expansion splice joint.

Plate Washers C are to be placed under both heads and nuts of splicing bolts for lap expansion and internal lap splice joint.

See Standard 630001 for details of guardrail not shown.

All dimensions are in inches (millimeters) unless otherwise shown.

FILE NAME =	USER NAME = letemove	DESIGNED -	REVISED -	STATE OF ILLINOIS DEPARTMENT OF TRANSPORTATION	EXISTING TUBULAR THRIE BEAM RETROFIT RAIL FOR BRIDGES (STANDARD 509001)	F.A. RTE.	SECTION	COUNTY	TOTAL SHEETS	SHEET NO.	
pw:\planroom.dot.illinois.gov\PIDOT\Documents\IDOT Offices\District 4\Projects\D4.68\Drawings\CADD\Drawings\D4xxxx-CADD.dgn		DRAWN -	REVISED -			VAR	D4 GUARDRAIL REPAIRS 2021-MCHD	VARIOUS	27	21	
Default	PLOT SCALE = 48.0000' / in.	CHECKED -	REVISED -			CONTRACT NO. 68F96					
	PLOT DATE = 12/8/2020	DATE -	REVISED -			SCALE:	SHEET 1	OF 3	SHEETS	STA.	TO STA.

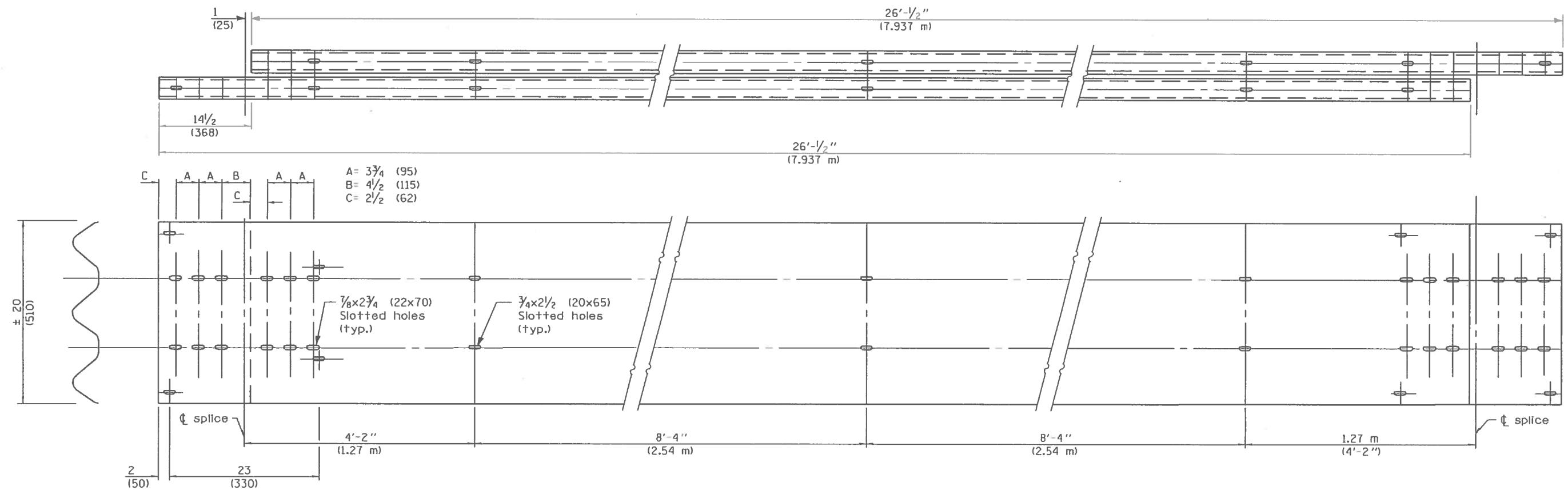

TUBULAR THRIE BEAM FOR LAP SPLICE JOINT

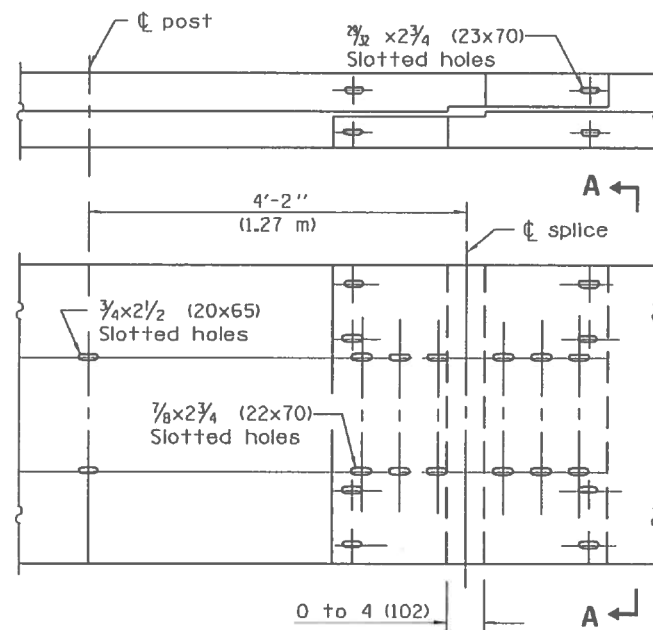

LAP EXPANSION SPLICE JOINT

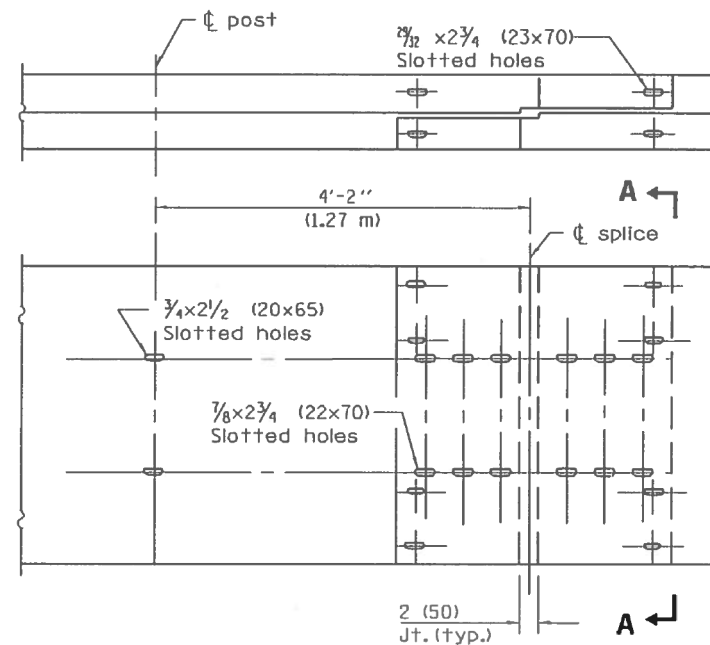

LAP SPLICE JOINT

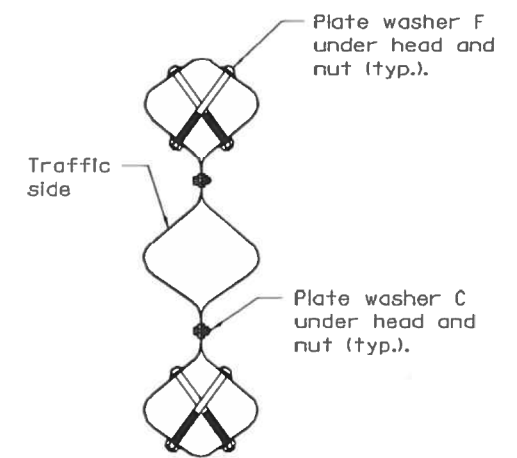

SECTION A-A

**DETAIL INCLUDED
FOR REPAIR ONLY**

FILE NAME =	USER NAME = letemove	DESIGNED -	REVISED -	STATE OF ILLINOIS DEPARTMENT OF TRANSPORTATION	EXISTING TUBULAR THRIE BEAM RETROFIT RAIL FOR BRIDGES (STANDARD 509001)	F.A. RTE.	SECTION	COUNTY	TOTAL SHEETS	SHEET NO.
pw\planroom.dot.illinois.gov\PIDOT\Documents\IDOT Offices\District 4\Projects\D4.68\Drawings\CADD\Drawings\D4xxxx-CADD.dgn	DRWING	REVISION	REVISION			VAR	D4 GUARDRAIL REPAIRS 2021-MCHD	VARIOUS	27	22
PLOT SCALE = 40.0000' / in.	CHECKED -	REVISION	REVISION			CONTRACT NO. 68F96				
Default	DATE -	REVISION	REVISION			ILLINOIS FED. AID PROJECT				
					SCALE:	SHEET 2 OF 3 SHEETS		STA.	TO STA.	

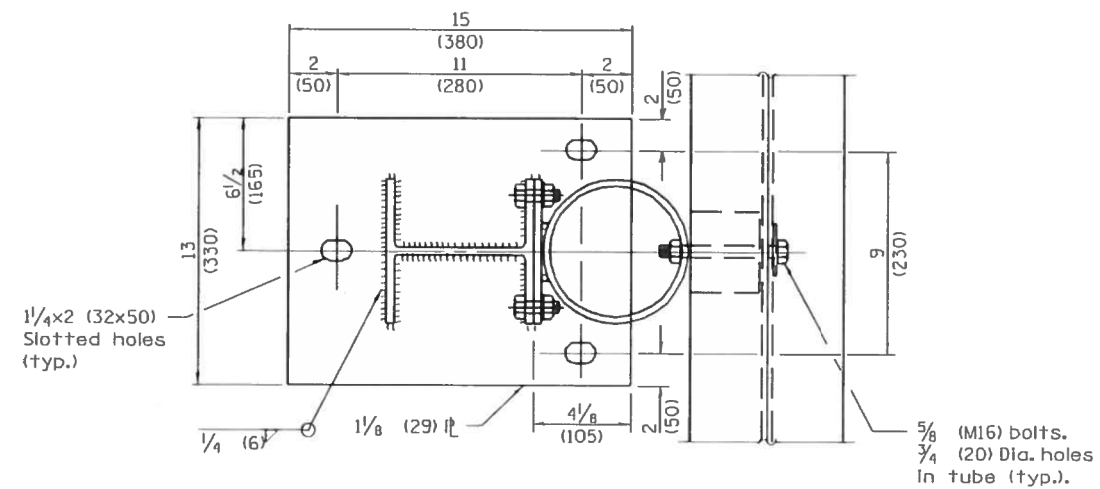

SECTION B-B

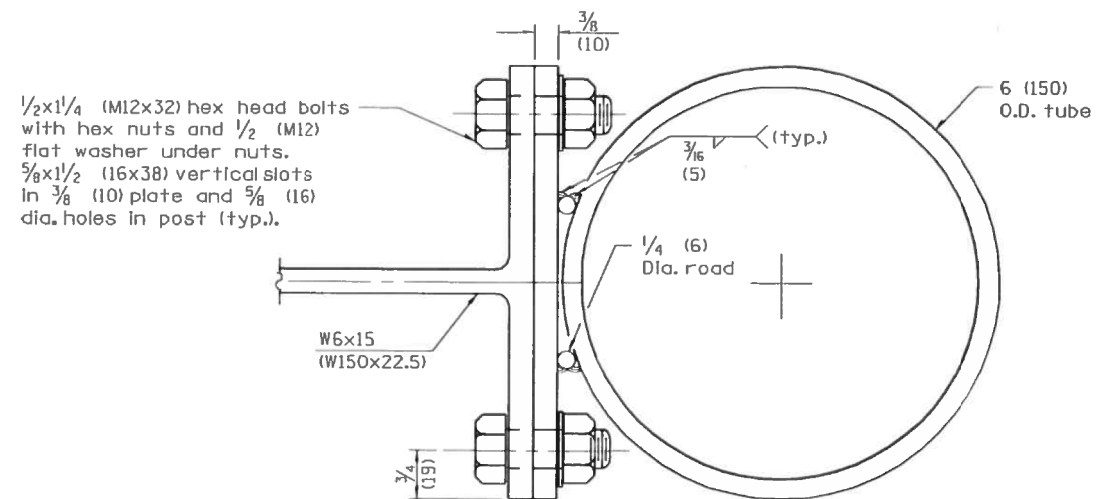

TUBE TO POST ATTACHMENT

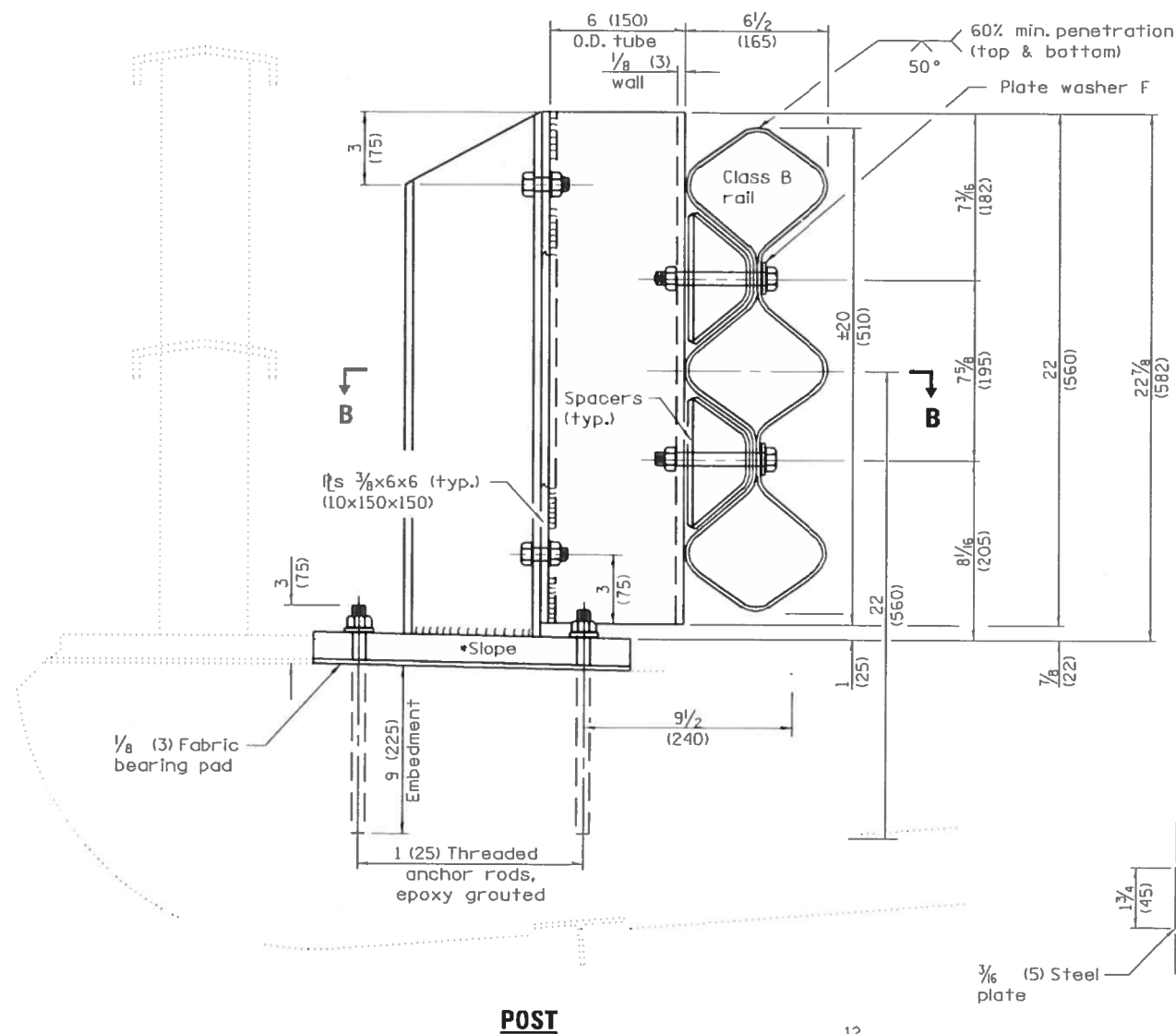

POST

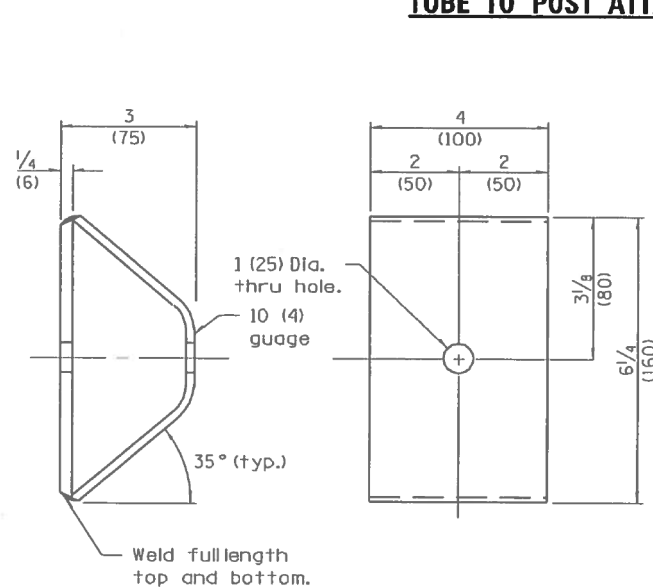

SPACER

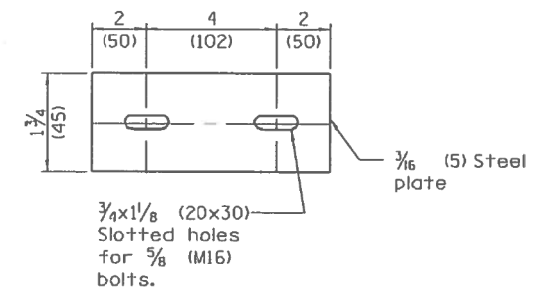

PLATE WASHER B

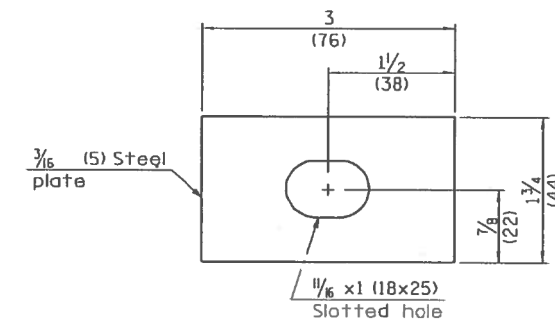

PLATE WASHER F

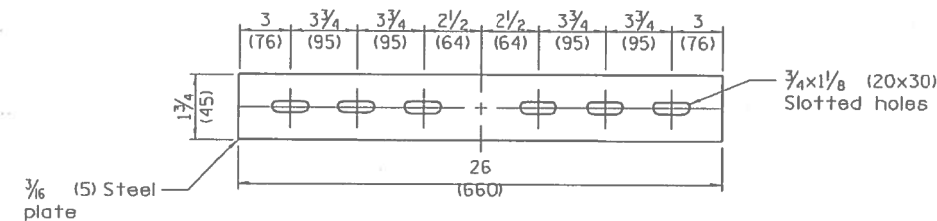

PLATE WASHER C

DETAIL INCLUDED FOR REPAIR ONLY

12
1/4
• Cut bottom of post to slope

FILE NAME =	USER NAME = letemove	DESIGNED -	REVISED -	STATE OF ILLINOIS DEPARTMENT OF TRANSPORTATION	EXISTING TUBULAR THRIE BEAM RETROFIT RAIL FOR BRIDGES (STANDARD 509001)	F.A. RTE.	SECTION	COUNTY	TOTAL SHEETS	SHEET NO.	
pw\planroom.dot.illinois.gov\PIDOT\Documents\IDOT Offices\District 4\Projects\D4.68\Drawings\CADD\Drawings\D4xxxx-CADD.dgn		REVISIONS				VAR	D4 GUARDRAIL REPAIRS 2021-MCHD	VARIOUS	27	23	
PLOT SCALE = 40.0000' / in.	CHECKED -	REVISED -				CONTRACT NO. 68F96					
Default	DATE -	REVISED -				SCALE:	SHEET 3	OF 3 SHEETS	STA.	TO STA.	ILLINOIS FED. AID PROJECT

DESIGNER NOTE: Use this CADD Standard when removing and re-erecting existing non-MGS guardrail that was originally installed prior to January 1, 2007 or to replace existing rail to match existing non-MGS rail. Note this is removing and re-erecting so the 27 1/2" height is maintained. If installing the new style MGS guardrail use the State Standard.

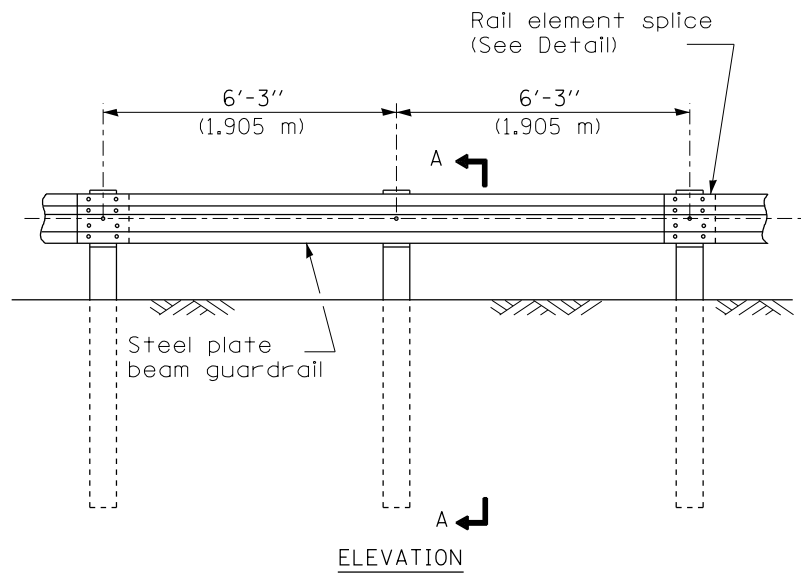

TYPE A

6'-3" (1.905 m) Typical post spacing

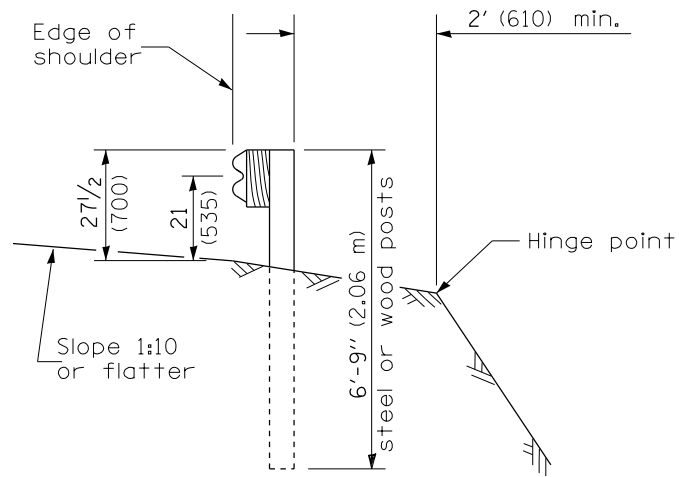

SECTION A-A

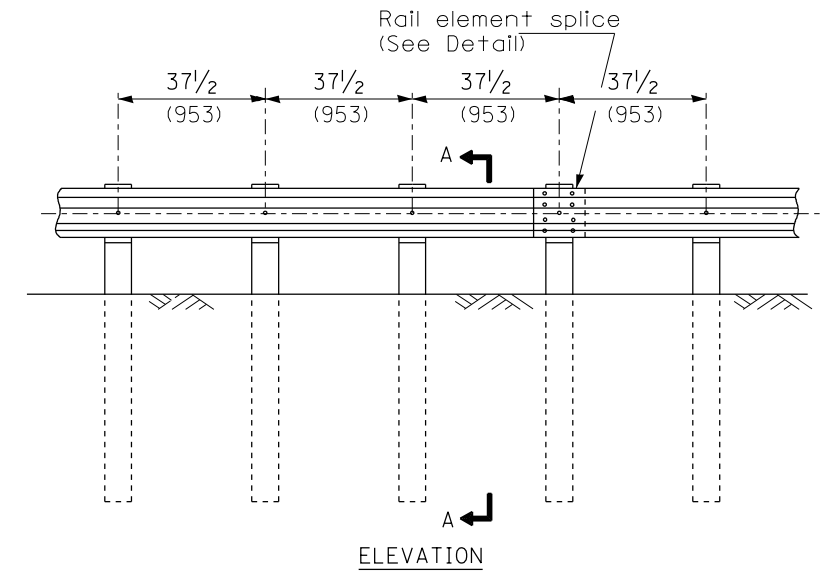

TYPE B

37 1/2 (953) Closed post spacing

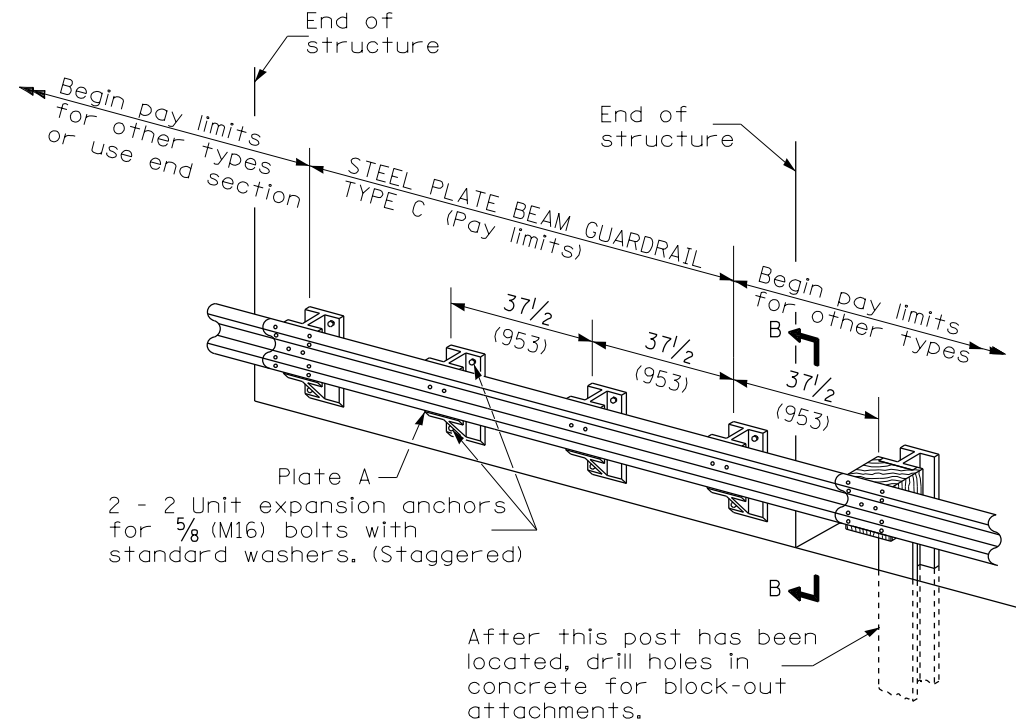

TYPE C

37 1/2 (953) Block-out spacing

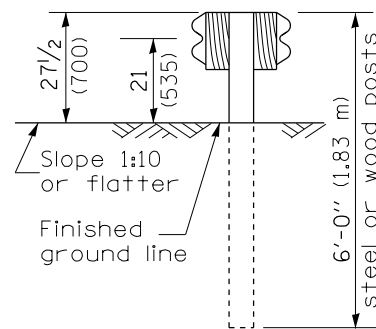

SECTION C-C

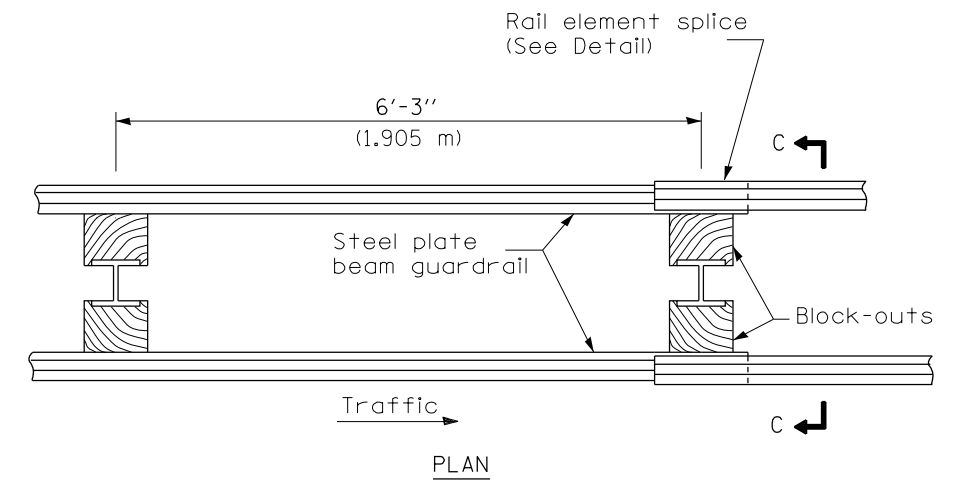

TYPE D

Double steel plate beam guardrail
6'-3" (1.905 m) typical post spacing

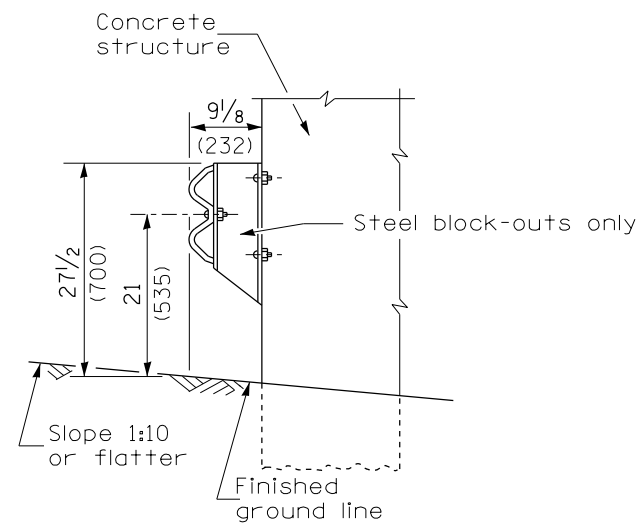

SECTION B-B

GENERAL NOTES

All slope ratios are expressed as units of vertical displacement to units of horizontal displacement (V:H).

All dimensions are in millimeters (inches) unless otherwise shown.

The existing steel posts may be drilled to match the bolt pattern shown herein for the wood block-out, or a new steel post shall be provided.

This detail is applicable to the guardrail system used prior to January 1, 2007. For details on the Midwest Guardrail System, see Standard 630001.

All dimensions are in inches (millimeters) unless otherwise noted.

03-01-07	NEW DETAIL	RJD			
03-07-11	Revised designer note	RJD			

**STATE OF ILLINOIS
DEPARTMENT OF TRANSPORTATION**

NOT TO SCALE

**STEEL PLATE BEAM GUARDRAIL, TYPE A,
6.75 FOOT POSTS**

SHT. 1 OF 4
CADD STD. 630011-D4

F.A. RTE.	SECTION	COUNTY	TOTAL SHEETS	SHEET NO.
VAR		VARIOUS	27	24
CONTRACT NO. 68F96				
FED. ROAD DIST. NO. ILLINOIS FED. AID PROJECT				

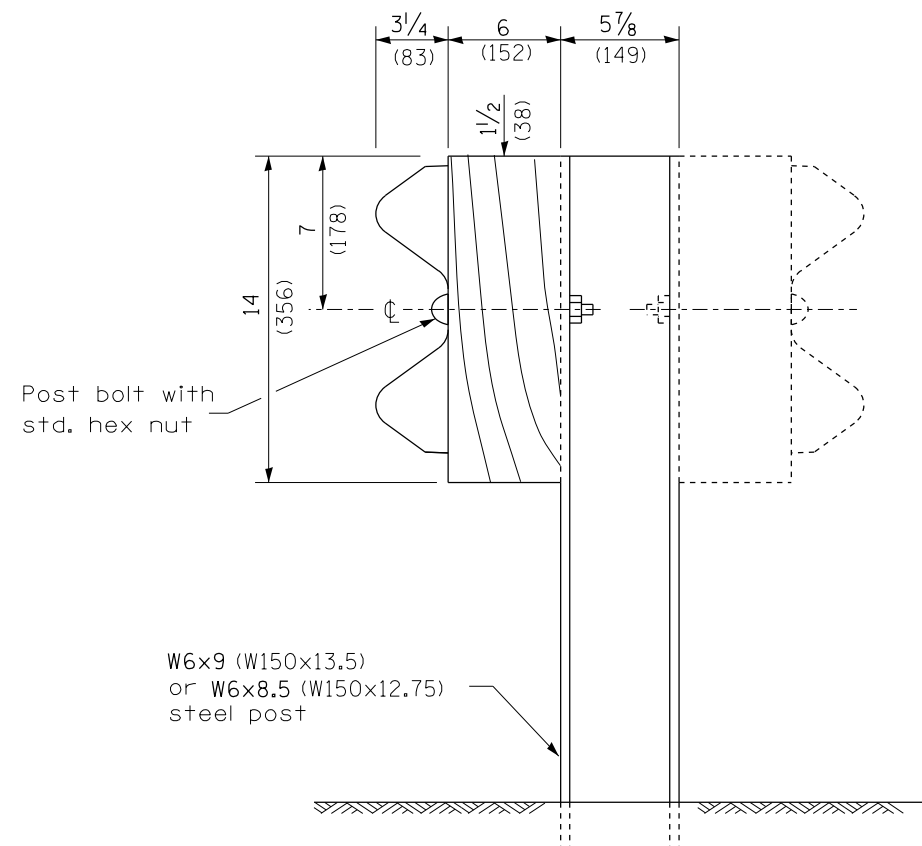

STEEL POST CONSTRUCTION

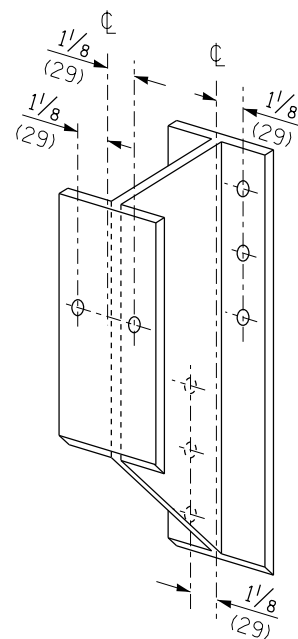

STEEL BLOCK-OUT DETAIL

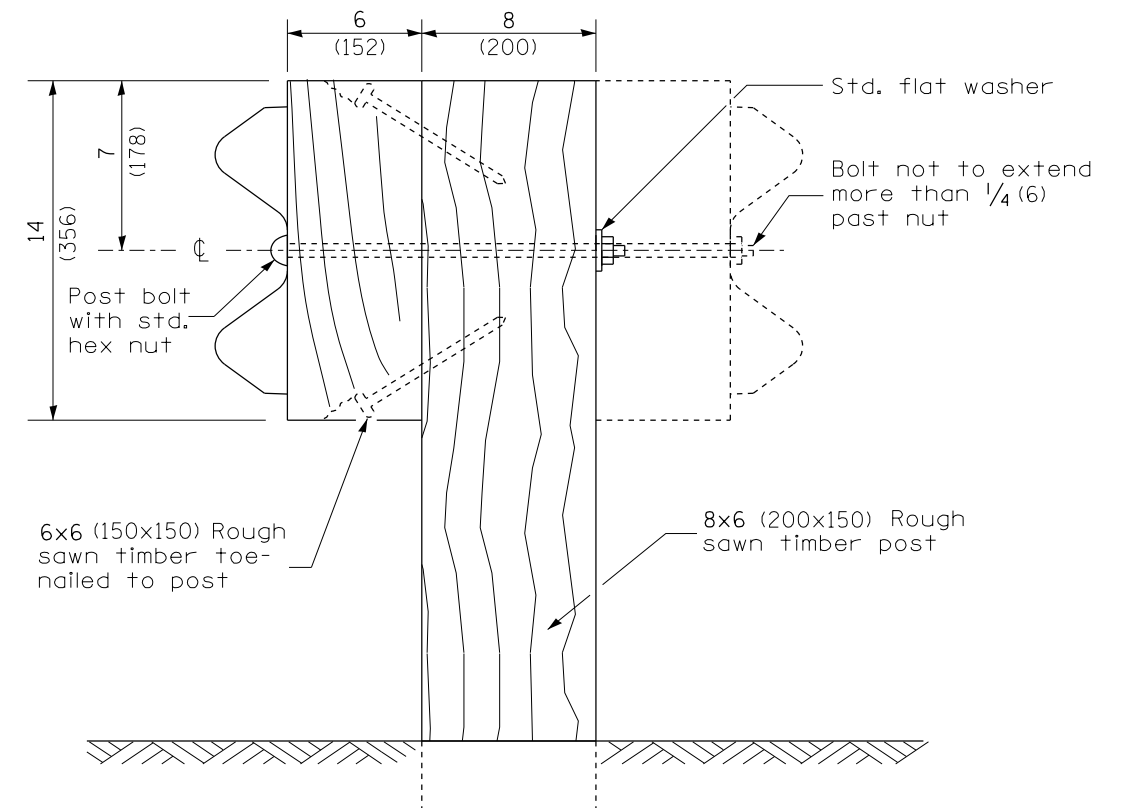

WOOD POST CONSTRUCTION

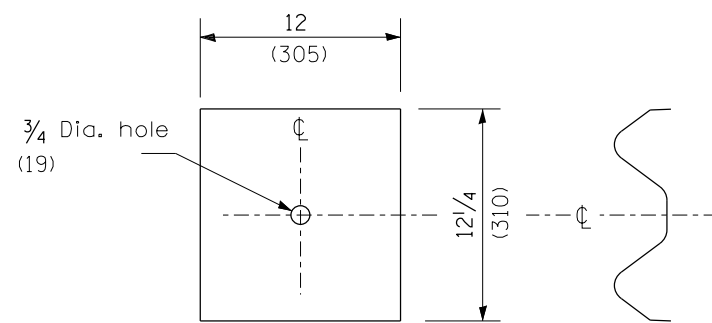

NOTE

Plate A shall be placed between rail element and block-out at non-splice mounting points only when steel block-outs are used.

PLATE A

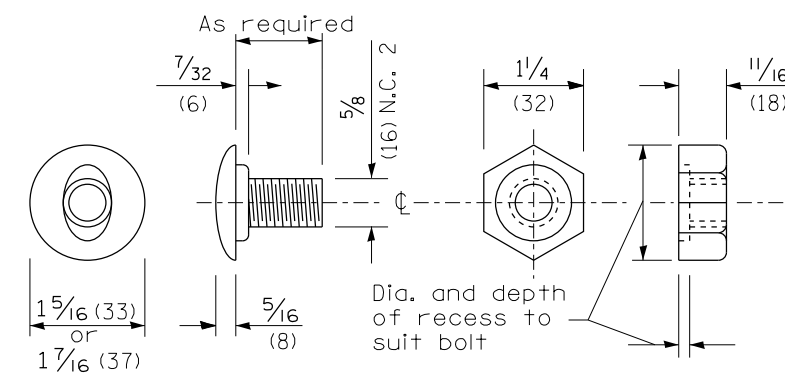

POST OR SPLICE BOLT & NUT

All dimensions are in inches (millimeters) unless otherwise noted.

STATE OF ILLINOIS
DEPARTMENT OF TRANSPORTATION

STEEL PLATE BEAM GUARDRAIL, TYPE A,
6.75 FOOT POSTS

NOT TO SCALE

SHT. 2 OF 4
CADD STD. 630011-D4

F.A. RTE.	SECTION	COUNTY	TOTAL SHEETS	SHEET NO.
VAR		VARIOUS	27	25
FED. ROAD DIST. NO. ILLINOIS FED. AID PROJECT			CONTRACT NO. 68F96	

Place standard end shoe between splice plate and rail element

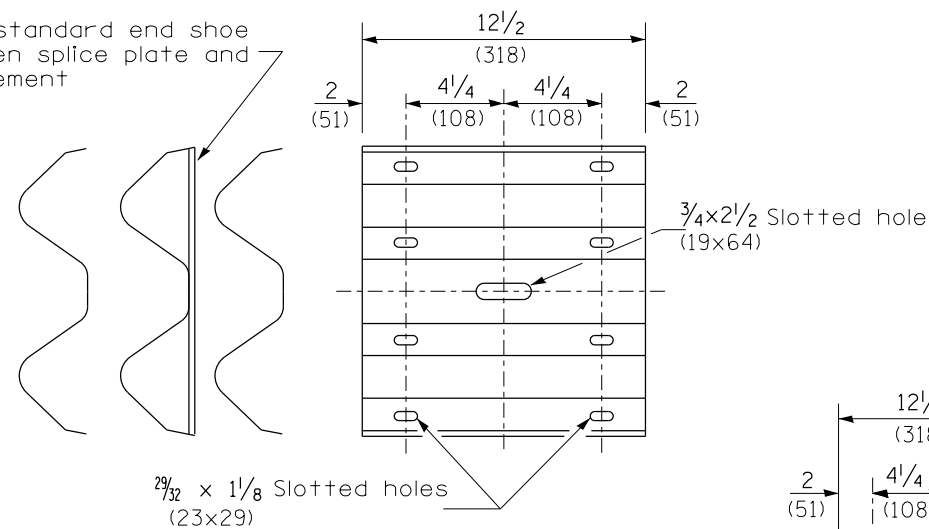

SPLICE PLATE

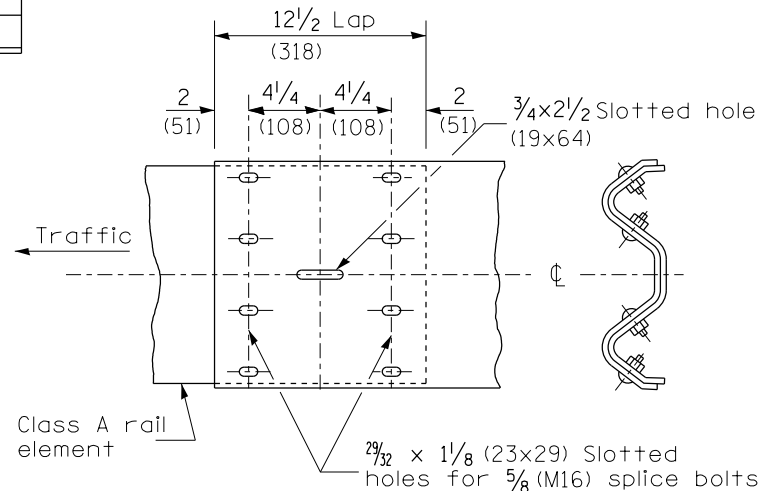

RAIL ELEMENT SPLICE

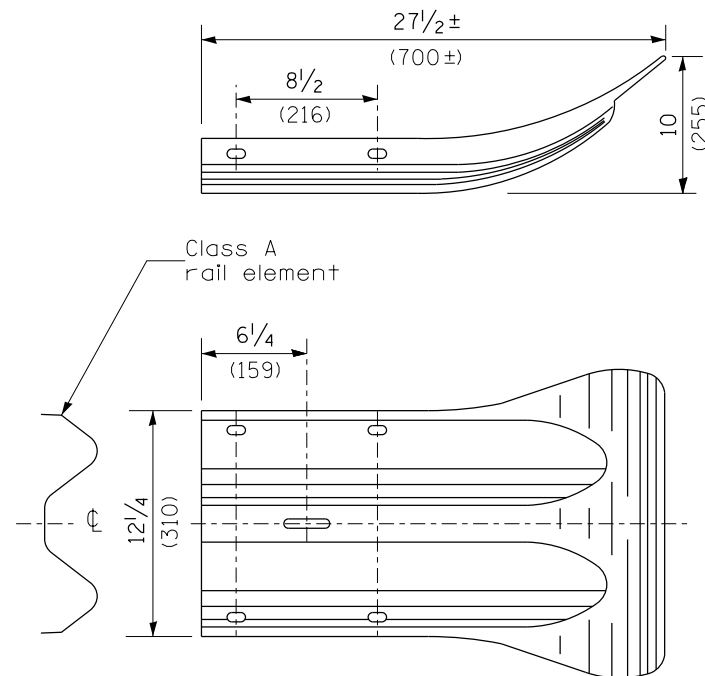

END SECTION

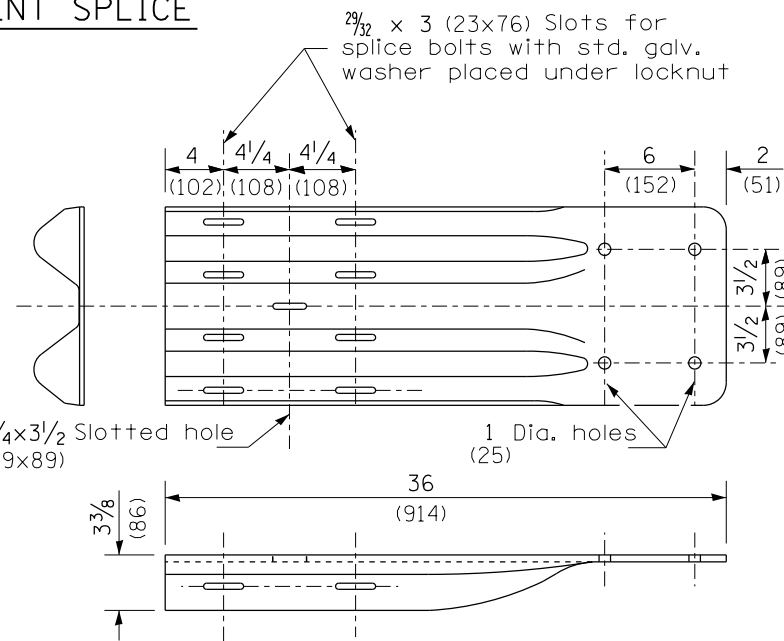

NOTE

When end shoe is attached to a bridge parapet which has an expansion joint, the bolts shall be provided with a locknut or double nut and shall be tightened only to a point that will allow guardrail movement.

The standard end shoe shall be attached to the concrete with pre-drilled or self-drilling anchor bolts. The anchor cone shall be set flush with the surface of the concrete.

Externally threaded studs protruding from the surface of the concrete will not be permitted.

END SHOE

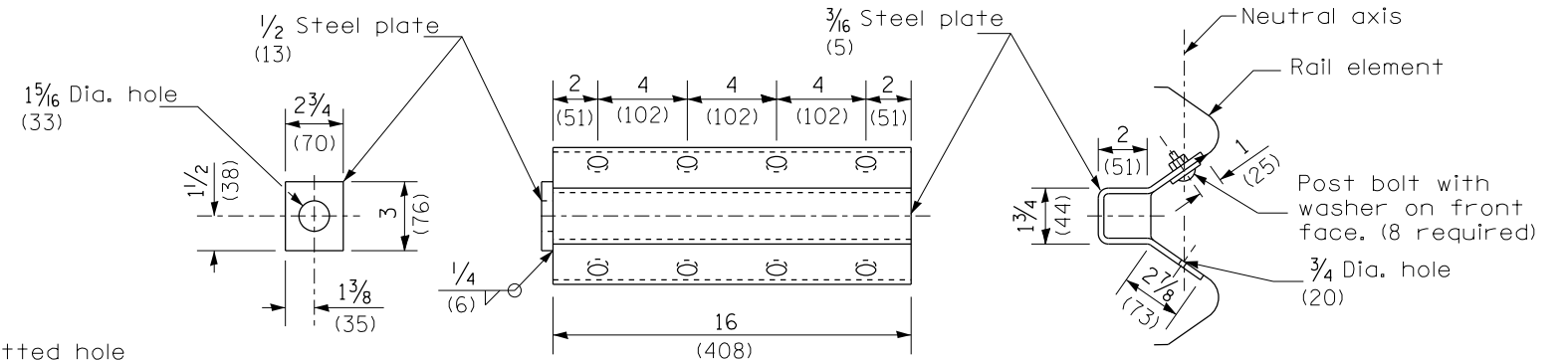

NOTE

Anchor plate T shall be used to attach cable assembly to guardrail when required on traffic barrier terminals.

ANCHOR PLATE T DETAILS

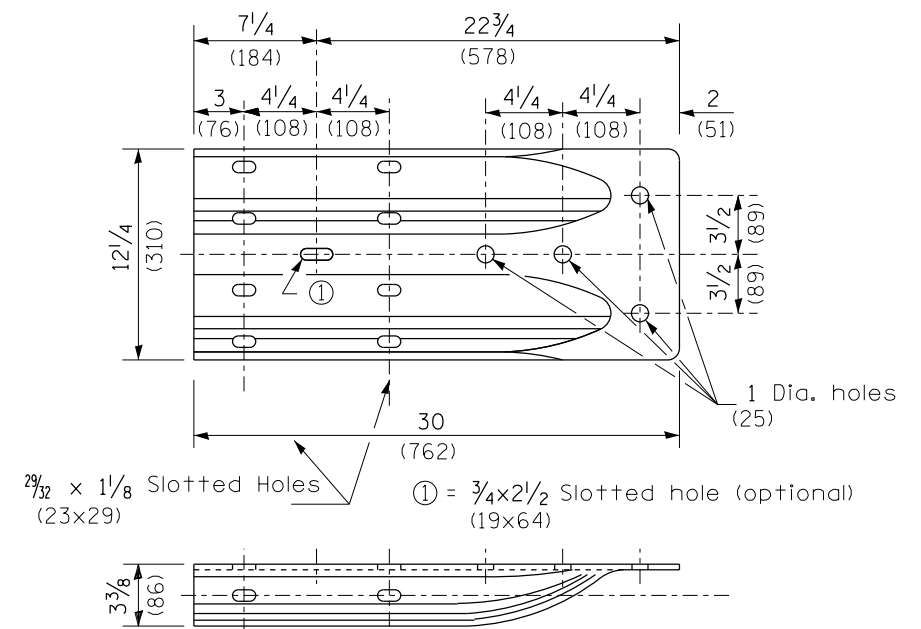

ALTERNATE END SHOE

All dimensions are in inches (millimeters) unless otherwise noted.

STATE OF ILLINOIS
DEPARTMENT OF TRANSPORTATION

STEEL PLATE BEAM GUARDRAIL, TYPE A,
6.75 FOOT POSTS

NOT TO SCALE

SHT. 3 OF 4
CADD STD. 630011-D4

F.A. RTE.	SECTION	COUNTY	TOTAL SHEETS	SHEET NO.
VAR		VARIOUS	27	26
			CONTRACT NO. 68F96	
FED. ROAD DIST. NO.		ILLINOIS FED. AID PROJECT		

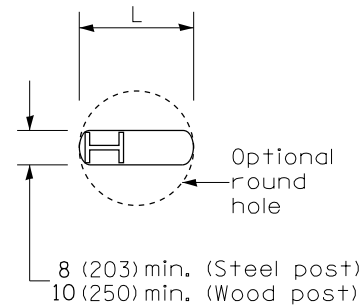

PLAN

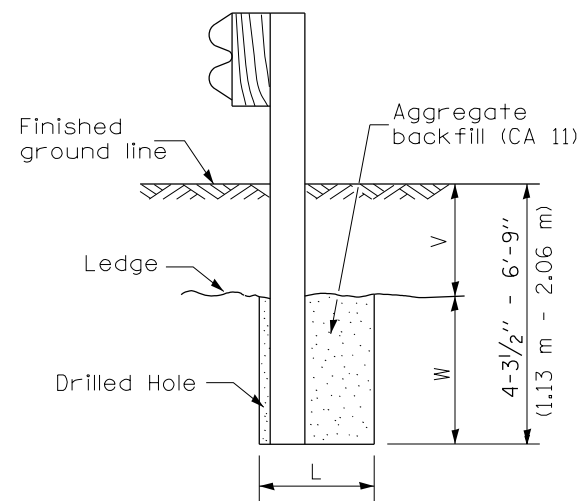

Note:
Ledge line is top of rock ledge or hard slag fill.

ELEVATION

FOOTING FOR POST WHEN IMPERVIOUS MATERIAL IS ENCOUNTERED

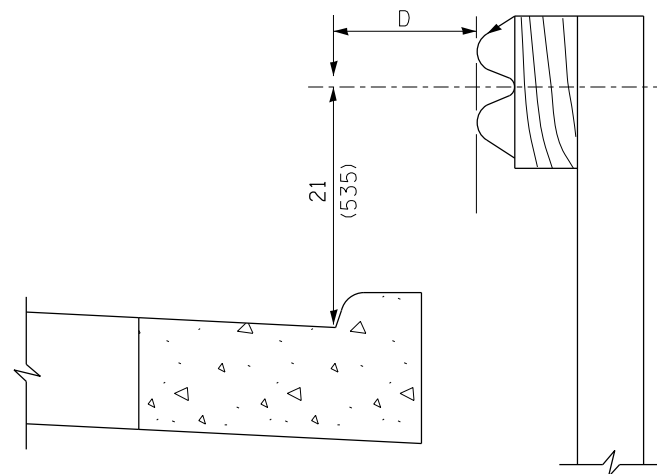

Note:

If it is necessary for D to be more than 12 (300) and less than 10'-0" (3.0 m) type M-2 (M-5) curb and gutter (Std. 606001) shall be used in front of and in advance of the guardrail.

GUARDRAIL PLACED BEHIND CURB

(D = 0 desirable to 12 (300) maximum)

V	W	L	
		Steel Post	Wood Post
0 - 18 (0 - 460)	24 (610)	21 (530)	23 (580)
>18 - 41.5 (>460 - 825)	12 (305)	8 (203)	10 (250)
>41.5 - 53.5 (>825 - 1.13 m)	12 - 0 (305 - 0)	8 (203)	10 (250)

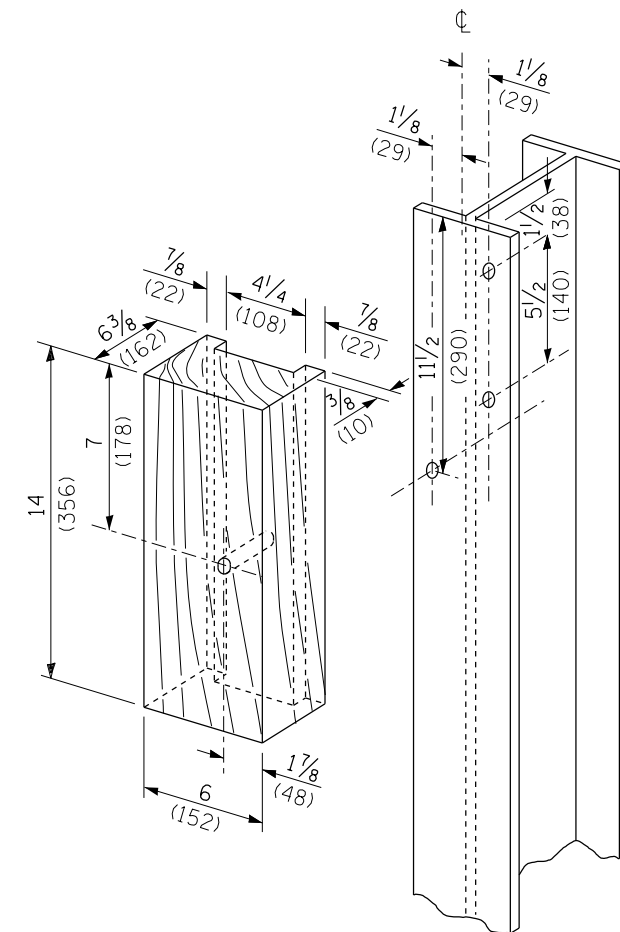

WOOD BLOCK-OUT AND STEEL POST DETAILS

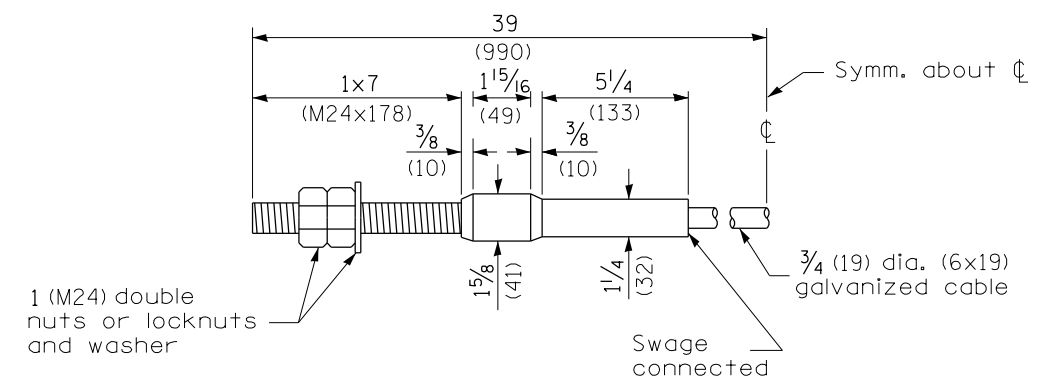

CABLE ASSEMBLY

(18,100 kg (40,000 lbs.) min. breaking strength)
Tighten to taut tension.

All dimensions are in inches (millimeters) unless otherwise noted.

STATE OF ILLINOIS
DEPARTMENT OF TRANSPORTATION

NOT TO SCALE

STEEL PLATE BEAM GUARDRAIL, TYPE A,
6.75 FOOT POSTS

SHT. 4 OF 4
CADD STD. 630011-D4

F.A. RTE.	SECTION	COUNTY	TOTAL SHEETS	SHEET NO.
VAR			27	27
			CONTRACT NO. 68F96	
FED. ROAD DIST. NO. ILLINOIS FED. AID PROJECT				