

HMA DRIVEWAY PAVEMENT SECTION

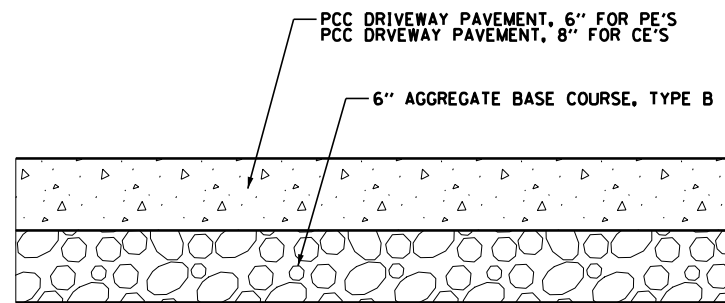

PCC DRIVEWAY PAVEMENT SECTION

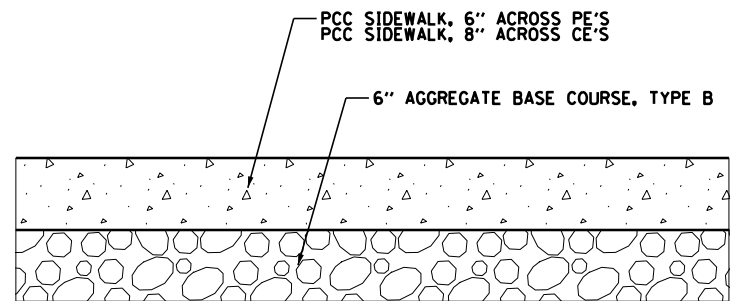

PCC SIDEWALK SECTION ACROSS DRIVEWAYS

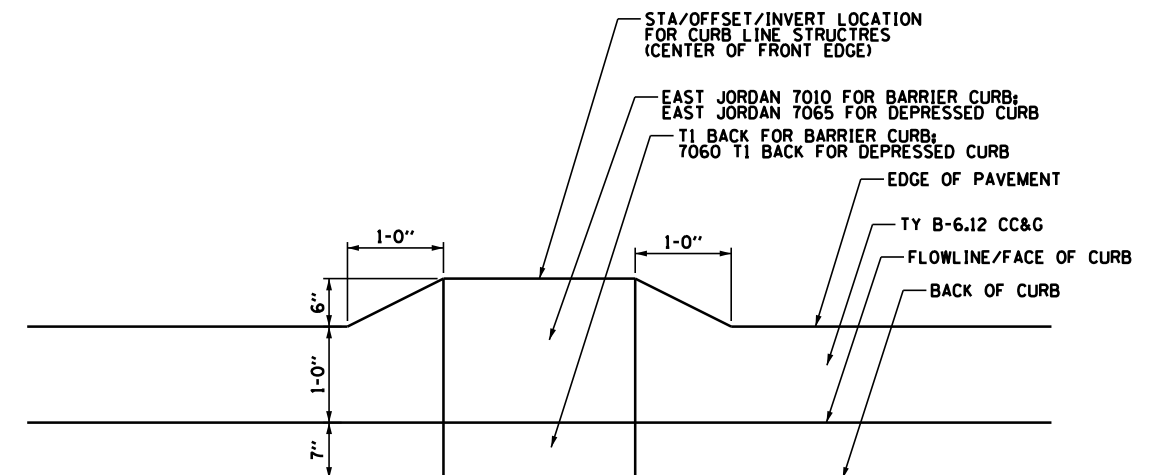

FRAME AND GRATE IN TY B-6.12 CC&G
DETAIL

FILE NAME =	USER NAME = mworman	DESIGNED -	REVISED - 2/19/21 ADDENDUM
N:\Algonquin\070273\070273.00132\Civil\DET_070273_132.SHT		DRAWN -	REVISED -
Default	PLOT SCALE = 2'	CHECKED -	REVISED -
	PLOT DATE = 2/19/2021	DATE -	REVISED -

STATE OF ILLINOIS
DEPARTMENT OF TRANSPORTATION

STAGE 1D HARRISON STREET AND MAIN STREET
CONSTRUCTION DETAILS

MUN. RTE. #660/0145	SECTION 16-00090-02-PV	COUNTY MCHENRY	TOTAL SHEETS 182	SHEET NO. 133
			CONTRACT NO. 61G60	
ILLINOIS FED. AID PROJECT				

SCALE: \$ SHEET OF SHEETS STA. TO STA.