

DATE: _____
 SURVEYED: _____
 PLAN: _____
 NOTE BOOK: _____
 NO. _____

DATE: _____
 SURVEYED: _____
 GRADES CHECKED: _____
 SIGNATURE: _____
 NO. _____

DATE: _____
 SURVEYED: _____
 GRADES CHECKED: _____
 SIGNATURE: _____
 NO. _____

CHRISTOPHER B. BURKE ENGINEERING LTD.
 3515 West Higgins Road, Suite 600
 Chicago, Illinois 60638
 (847) 823-0500

TEMPORARY TRAFFIC SIGNAL LEGEND

- ▲ TEMPORARY TRAFFIC SIGNAL HEAD SPAN WIRE MOUNTED ORIGINAL LOCATION
- ▲ TEMPORARY TRAFFIC SIGNAL HEAD SPAN WIRE MOUNTED SECONDARY LOCATION
- ⊗ TEMPORARY WOOD POLE (CLASS 5 OR BETTER) 45 FOOT (13.7m) MINIMUM DOWN GUY
- ⊠ TEMPORARY CONTROLLER CABINET
- TEMPORARY SPAN WIRE, TETHER WIRE, AND CABLE
- ⊕ TEMPORARY SERVICE INSTALLATION
- ⊖ TEMPORARY PEDESTRIAN SIGNAL HEAD, BRACKET MOUNTED
- ⊙ VIDEO DETECTION CAMERA
- ⊙ PEDESTRIAN PUSHBUTTON DETECTOR
- ⊙ EMERGENCY VEHICLE LIGHT DETECTOR
- ⊙ CONFIRMATION BEACON
- VEHICLE DETECTOR, INDUCTION LOOP
- ⊖ UNIT DUCT
- COMMON TRENCH
- G.S. CONDUIT IN TRENCH (T) OR PUSHED (P)
- ⊖ HANDHOLE
- ⊖ HEAVY DUTY HANDHOLE

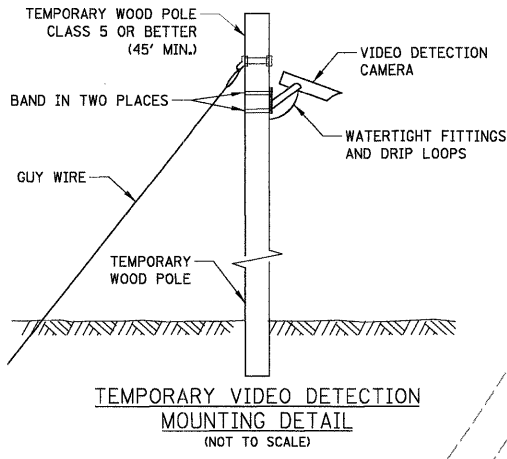

EXISTING EQUIPMENT TO BE REMOVED LEGEND

- ⊖ EXISTING SIGNAL HEAD TO BE REMOVED
- ⊖ EXISTING SERVICE INSTALLATION TO BE REMOVED
- ⊖ EXISTING SIGNAL POST AND FOUNDATION TO BE REMOVED
- ⊖ EXISTING ALUMINUM MAST ARM POLE AND FOUNDATION TO BE REMOVED
- ⊖ EXISTING CONTROLLER AND FOUNDATION TO BE REMOVED
- ⊖ EXISTING HANDHOLE TO BE REMOVED
- ⊖ EXISTING PEDESTRIAN SIGNAL HEAD TO BE REMOVED
- ⊖ EXISTING PEDESTRIAN PUSHBUTTON TO BE REMOVED
- ⊖ EMERGENCY VEHICLE LIGHT DETECTOR TO BE REMOVED
- ⊖ CONFIRMATION BEACON TO BE REMOVED
- ⊖ EXISTING HEAVY-DUTY HANDHOLE TO BE REMOVED
- ⊖ EXISTING STEEL MAST ARM POLE AND FOUNDATION TO BE REMOVED
- ⊖ ABANDON



R10-5
 24" x 30"
 1 REQUIRED
 (INCIDENTAL TO TEMPORARY TRAFFIC SIGNAL INSTALLATION)

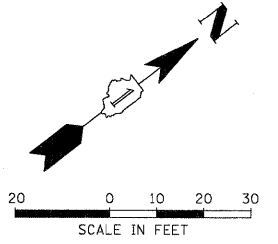

RAMP "C" TO F.A. I-57

IL ROUTE 83 (147th ST.)

RAMP "D" FROM F.A. I-57

NOTES FOR TEMPORARY TRAFFIC SIGNALS

1. ALL CONTROL EQUIPMENT INCLUDING EMERGENCY PRE-EMPTION AND COMMUNICATION DEVICES FOR THE TEMPORARY TRAFFIC SIGNAL(S) SHALL BE FURNISHED BY THE CONTRACTOR.
2. ONLY CONTROLLERS SUPPLIED BY ONE OF THE DISTRICT APPROVED CLOSED LOOP EQUIPMENT MANUFACTURERS WILL BE APPROVED FOR USE AT TEMPORARY SIGNAL LOCATIONS. ALL CONTROLLERS USED FOR TEMPORARY TRAFFIC SIGNALS SHALL BE FULLY ACTUATED NEMA MICROPROCESSOR BASED WITH RS232 DATA ENTRY PORTS COMPATIBLE WITH EXISTING MONITORING SOFTWARE APPROVED BY IDOT DISTRICT 1, INSTALLED IN A NEMA TS1 OR TS2 CABINET. ONLY ONE BRAND OF CONTROLLER WILL BE ACCEPTED FOR ANY ONE CONTRACT.
3. ALL TRAFFIC SIGNAL SECTIONS AND PEDESTRIAN SIGNAL SECTIONS SHALL BE 12" (300mm). HEADS SHALL BE PLACED AS INDICATED ON THE TEMPORARY TRAFFIC SIGNAL PLAN OR AS DIRECTED BY THE ENGINEER. THE CONTRACTOR SHALL FURNISH ENOUGH CABLE SLACK TO RELOCATE HEADS TO ANY POSITION ON THE SPAN WIRE OR AT LOCATIONS ILLUSTRATED ON THE PLANS FOR CONSTRUCTION STAGING. THE TEMPORARY TRAFFIC SIGNAL SHALL REMAIN IN OPERATION DURING ALL SIGNAL HEAD RELOCATIONS. EACH TEMPORARY TRAFFIC SIGNAL HEAD SHALL HAVE ITS OWN CABLE FROM THE CONTROLLER CABINET TO THE SIGNAL HEAD.
4. ALL EXISTING STREET NAME AND INTERSECTION REGULATORY SIGNS SHALL BE REMOVED FROM EXISTING POLES, RELOCATED AND SECURELY FASTENED TO THE SIGNAL SPAN WIRE OR WOOD POLE AS DIRECTED BY THE ENGINEER.
5. ANY TEMPORARY SIGNAL WITHIN AN EXISTING CLOSED LOOP TRAFFIC SIGNAL SYSTEM SHALL BE INTERCONNECTED TO THAT SYSTEM USING SIMILAR BRAND CONTROL EQUIPMENT.
6. THE TEMPORARY TRAFFIC SIGNAL SHALL HAVE THE SIGNAL HEAD DISPLAYS, SIGNAL HEAD PLACEMENTS AND CONTROLLER PHASING MATCH THE EXISTING TRAFFIC SIGNAL, AT THE TIME OF THE TURN ON, IF NO TRAFFIC STAGING IS IN PLACE OR WILL NOT BE STAGED ON THE DAY OF THE TURN ON.

THE FOLLOWING ITEMS SHALL BE REMOVED BY THE CONTRACTOR AND SHALL BE DISPOSED OF BY THEM OUTSIDE THE RIGHT-OF-WAY AT THEIR EXPENSE. THE SALVAGE VALUE OF THE REMOVED EQUIPMENT SHALL BE REFLECTED IN THE CONTRACT BID PRICE.

- 1 EACH CONTROLLER AND CABINET (COMPLETE)
- 10 EACH SIGNAL HEAD, 1-FACE, 3-SECTION
- 1 EACH SIGNAL HEAD, 2-FACE, 3-SECTION
- 3 EACH ALUMINUM MAST ARM AND POLE
- 3 EACH SIGNAL POST

RESTORATION OF WORK AREA. RESTORATION OF THE TRAFFIC SIGNAL WORK AREA SHALL BE INCIDENTAL TO THE RELATED PAY ITEM SUCH AS FOUNDATION, CONDUIT, HANDHOLE, TRENCH AND BACKFILL, ETC., AND NO EXTRA COMPENSATION SHALL BE ALLOWED. ALL ROADWAY SURFACES SUCH AS SHOULDERS, MEDIANS, SIDEWALKS, PAVEMENT, ETC. SHALL BE REPLACED IN KIND. ALL DAMAGE TO MOWED LAWNS SHALL BE REPLACED WITH AN APPROVED SOD, AND ALL DAMAGE TO UNMOWED FIELDS SHALL BE SEEDED IN ACCORDANCE WITH STANDARD SPECIFICATIONS 252 AND 250 RESPECTIVELY.

MATCH LINE STA. 27+50 (SEE SHEET 21)

| | | | | | | | | | | |
|---|----------------------|-------------------|-----------|---|--|---|---------------------|-------------|-----------------|--------------|
| FILE NAME = N:\dot\08040\TASK 0 - IL 83\T-traffic\TMP | USER NAME = FPACIONE | DESIGNED - ABR | REVISED - | STATE OF ILLINOIS DEPARTMENT OF TRANSPORTATION | TEMPORARY TRAFFIC SIGNAL INSTALLATION AND REMOVE EXISTING TRAFFIC SIGNAL EQUIPMENT PLAN IL ROUTE 83 (147th ST.) AND F.A. I-57 RAMPS "C" AND "D" POSEN, ILLINOIS | F.A.U. RTE. 1602 | SECTION 2008-054 TS | COUNTY COOK | TOTAL SHEETS 40 | SHEET NO. 19 |
| PLANT | NOTE BOOK | CHECKED - MJT | REVISED - | | | CONTRACT NO. 60F06 | | | | |
| PLANT | NOTE BOOK | DATE - 11/24/2009 | REVISED - | | | FED. ROAD DIST. NO. ILLINOIS FED. AID PROJECT | | | | |
| PLANT | NOTE BOOK | | | | | SCALE: 1"= 20' SHEET NO. OF SHEETS STA. TO STA. | | | | |